

### GENERAL

The STK4000 series sight glass type flow monitors with flapper are designed for the ultimate cost performance. The flapper itself works as an indicator. Both fluid flow and flow rate can be monitored by watching the movement of the flapper through the scaled sight glass.

### FEATURES

- Simple structure
- Easy monitoring of flow and state of fluids
- Flow monitoring by movement of flapper
- Easy maintenance
- Selectable flow direction

### PRINCIPLE

The STK4000 series measures flow rate by using the principle of variable area flow meters. The flow path is throttled by a flapper whose angle is variable, being supported by a spring. A fluid flow produces a differential pressure between the front and the rear of the flapper. This differential pressure displaces the flapper, causing changes in the cross section of flow path and the spring force. The flapper rests at the position at which the force due to the differential pressure balances the spring force. The flapper position read off the scaled sight glass indicates the flow rate.

### STANDARD SPECIFICATIONS

- Meter size : 15 mm to 300 mm
- Measurement range : 0.6 to 600 m<sup>3</sup>/h
- Process connection : 15 mm, 20 mm: Rc tapered female thread  
25 mm to 300 mm: flange
- Measured fluid : Water and water-like liquids that are transparent
- Fluid pressure : 15 mm to 125 mm : 1.0 MPa  
150 mm : 0.8 MPa  
200 mm : 0.6 MPa  
250 mm, 300 mm : 0.5 MPa
- Fluid temperature : 0°C to 80°C
- Flow direction : Horizontal or vertical
- Accuracy : ±5.0% F. S. (Factory calibration accuracy for water at 20°C)



#### ● Materials

Description		Iron-based material (Material code: S)	Stainless steel (Material code: 4)
Main body <sup>1</sup>	15 to 100 mm	Cast iron (FCD450)	Stainless cast steel (SCS14)
	125 to 300 mm	Carbon steel (SS400)	Stainless steel (SUS304)
Detector <sup>1</sup>		Stainless steel (SUS304)	
Sight glass <sup>1</sup>		Reinforced glass	
Packing <sup>1</sup>		PTFE	
Glass holding plate		Cast iron (FCD450)	
Bolts and nuts for glass holding plate		Carbon steel (standard)	Stainless steel (standard)

\*1: Wetted part

- Painting/Painting color<sup>2</sup> : Epoxy resin/Gray

\*2 No painting on stainless steel parts

Flow paths (wetted parts) of iron-based main bodies are painted.

● Flow direction : Select one of the four options below when placing an order.

● Mounting angle : The scale surface must be mounted vertically.

\* When mounting on a horizontal piping, avoid mounting the flow monitor with the scale surface facing upward.

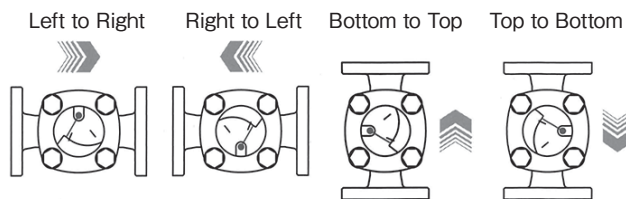

**FLOW RATE RANGE**

Flow rate unit [m³/h]	Flow rate range code/Flow rate scale (m³/h)													
Scale type	15 mm		20 mm		25 mm		32 mm		40 mm		50 mm		65 mm	
0.16 to 0.6	01M	0.16 to 0.6	01M	0.16 to 0.6										
0.15 to 0.7	02M	0.15 to 0.7	02M	0.15 to 0.7										
0.15 to 0.8	03M	0.15 to 0.8	03M	0.15 to 0.8										
0.2 to 0.9	04M	0.2 to 0.9	04M	0.2 to 0.9										
0.2 to 1	05M	0.2 to 1	05M	0.2 to 1										
0.25 to 1.2	06M	0.25 to 1.2	06M	0.25 to 1.2	01M	0.25 to 1.2	01M	0.25 to 1.2						
0.3 to 1.5	07M	0.3 to 1.5	07M	0.3 to 1.5	02M	0.3 to 1.5	02M	0.3 to 1.5						
0.4 to 2	08M	0.4 to 2	08M	0.4 to 2	03M	0.4 to 2	03M	0.4 to 2						
0.5 to 2.5					04M	0.5 to 2.5	04M	0.5 to 2.5						
0.6 to 3					05M	0.6 to 3	05M	0.6 to 3	01M	0.6 to 3				
0.8 to 3.6					06M	0.8 to 3.6	06M	0.8 to 3.6	02M	0.8 to 3.6	01M	0.8 to 3.6		
0.8 to 4					07M	0.8 to 4	07M	0.8 to 4	03M	0.8 to 4	02M	0.8 to 4		
1 to 4.6					08M	1 to 4.6	08M	1 to 4.6	04M	1 to 4.6	03M	1 to 4.6		
1 to 5					09M	1 to 5	09M	1 to 5	05M	1 to 5	04M	1 to 5		
1.2 to 6									06M	1.2 to 6	05M	1.2 to 6		
1.5 to 7									07M	1.5 to 7	06M	1.5 to 7		
1.5 to 8									08M	1.5 to 8	07M	1.5 to 8	01M	1.5 to 8
2 to 9									09M	2 to 9	08M	2 to 9	02M	2 to 9
2 to 10									10M	2 to 10	09M	2 to 10	03M	2 to 10
2.5 to 12											10M	2.5 to 12	04M	2.5 to 12
3 to 15											11M	3 to 15	05M	3 to 15
4 to 20													06M	4 to 20
5 to 25													07M	5 to 25
6 to 30													08M	6 to 30
8 to 36													09M	8 to 36
Scale type	80 mm		100 mm		125 mm		150 mm		200 mm		250 mm		300 mm	
3 to 15	01M	3 to 15												
4 to 20	02M	4 to 20	01M	4 to 20										
5 to 25	03M	5 to 25	02M	5 to 25	01M	5 to 25								
6 to 30	04M	6 to 30	03M	6 to 30	02M	6 to 30								
8 to 36	05M	8 to 36	04M	8 to 36	03M	8 to 36								
8 to 40	06M	8 to 40	05M	8 to 40	04M	8 to 40								
10 to 46	07M	10 to 46	06M	10 to 46	05M	10 to 46								
10 to 50	08M	10 to 50	07M	10 to 50	06M	10 to 50								
12 to 60			08M	12 to 60	07M	12 to 60	01M	12 to 60						
15 to 70			09M	15 to 70	08M	15 to 70	02M	15 to 70	01M	15 to 70				
15 to 80			10M	15 to 80	09M	15 to 80	03M	15 to 80	02M	15 to 80				
20 to 90			11M	20 to 90	10M	20 to 90	04M	20 to 90	03M	20 to 90				
20 to 100					11M	20 to 100	05M	20 to 100	04M	20 to 100				
25 to 120					12M	25 to 120	06M	25 to 120	05M	25 to 120				
30 to 150					13M	30 to 150	07M	30 to 150	06M	30 to 150	01M	30 to 150		
40 to 200							08M	40 to 200	07M	40 to 200	02M	40 to 200	01M	40 to 200
50 to 250									08M	50 to 250	03M	50 to 250	02M	50 to 250
60 to 300									09M	60 to 300	04M	60 to 300	03M	60 to 300
80 to 360									10M	80 to 360	05M	80 to 360	04M	80 to 360
80 to 400									11M	80 to 400	06M	80 to 400	05M	80 to 400
100 to 460									12M	100 to 460	07M	100 to 460	06M	100 to 460
100 to 500											08M	100 to 500	07M	100 to 500
120 to 600													08M	120 to 600

Flow rate unit [L/min]	Flow rate range code/Flow rate scale (L/min)													
Scale type	15 mm		20 mm		25 mm		32 mm		40 mm		50 mm		65 mm	
2.5 to 10	01L	2.5 to 10	01L	2.5 to 10										
2.5 to 12	02L	2.5 to 12	02L	2.5 to 12										
3 to 15	03L	3 to 15	03L	3 to 15										
4 to 20	04L	4 to 20	04L	4 to 20	01L	4 to 20	01L	4 to 20						
6 to 30	05L	6 to 30	05L	6 to 30	02L	6 to 30	02L	6 to 30						
8 to 36					03L	8 to 36	03L	8 to 36						
8 to 40					04L	8 to 40	04L	8 to 40						
10 to 46					05L	10 to 46	05L	10 to 46						
10 to 50					06L	10 to 50	06L	10 to 50	01L	10 to 50				
12 to 60					07L	12 to 60	07L	12 to 60	02L	12 to 60				
15 to 70					08L	15 to 70	08L	15 to 70	03L	15 to 70	01L	15 to 70		
15 to 80					09L	15 to 80	09L	15 to 80	04L	15 to 80	02L	15 to 80		
20 to 90									05L	20 to 90	03L	20 to 90		
20 to 100									06L	20 to 100	04L	20 to 100		
25 to 120									07L	25 to 120	05L	25 to 120		
30 to 150									08L	30 to 150	06L	30 to 150	01L	30 to 150
40 to 200											07L	40 to 200	02L	40 to 200
50 to 250											08L	50 to 250	03L	50 to 250
60 to 300													04L	60 to 300
80 to 360													05L	80 to 360
80 to 400													06L	80 to 400
100 to 460													07L	100 to 460
100 to 500													08L	100 to 500
120 to 600													09L	120 to 600
Scale type	80 mm		100 mm		125 mm		150 mm		200 mm		250 mm		300 mm	
40 to 200	01L	40 to 200												
50 to 250	02L	50 to 250												
60 to 300	03L	60 to 300												
80 to 360	04L	80 to 360												
80 to 400	05L	80 to 400	01L	80 to 400	01L	80 to 400								
100 to 460	06L	100 to 460	02L	100 to 460	02L	100 to 460								
100 to 500	07L	100 to 500	03L	100 to 500	03L	100 to 500								
120 to 600	08L	120 to 600	04L	120 to 600	04L	120 to 600								
150 to 700	09L	150 to 700	05L	150 to 700	05L	150 to 700								
150 to 800	10L	150 to 800	06L	150 to 800	06L	150 to 800								
200 to 900			07L	200 to 900	07L	200 to 900	01L	200 to 900						
200 to 1000			08L	200 to 1000	08L	200 to 1000	02L	200 to 1000	01L	200 to 1000				
250 to 1200			09L	250 to 1200	09L	250 to 1200	03L	250 to 1200	02L	250 to 1200				
300 to 1500			10L	300 to 1500	10L	300 to 1500	04L	300 to 1500	03L	300 to 1500				
400 to 2000					11L	400 to 2000	05L	400 to 2000	04L	400 to 2000				
500 to 2500					12L	500 to 2500	06L	500 to 2500	05L	500 to 2500	01L	500 to 2500		
600 to 3000							07L	600 to 3000	06L	600 to 3000	02L	600 to 3000		
800 to 3600									07L	800 to 3600	03L	800 to 3600		
800 to 4000									08L	800 to 4000	04L	800 to 4000	01L	800 to 4000
1000 to 4600									09L	1000 to 4600	05L	1000 to 4600	02L	1000 to 4600
1000 to 5000									10L	1000 to 5000	06L	1000 to 5000	03L	1000 to 5000
1200 to 6000									11L	1200 to 6000	07L	1200 to 6000	04L	1200 to 6000
1500 to 7000									12L	1500 to 7000	08L	1500 to 7000	05L	1500 to 7000
1500 to 8000											09L	1500 to 8000	06L	1500 to 8000
2000 to 9000													07L	2000 to 9000

**CAUTIONS**

- This flow monitor contains glass parts. To prevent the glass from breaking, avoid the following:
  - Applying excessive pressure
  - Impact pressure due to sudden fluid inflow
  - Thermal shock
  - Mechanical shock
- If the ambient temperature falls below 0°C with residual liquid remaining in the measuring tube, the residual liquid will freeze and may break the glass. Drain the residual liquid completely if there is a possibility of freezing when the system is not being used.
- Make sure to flush the piping before mounting this product, to eliminate completely any residue in the piping.
- Avoid sudden valve operation. Especially at the start of operation, opening a valve suddenly will give rise to an excessive flow of fluid, which may cause failure or breakage of the internal flappers and other parts.

EXTERNAL DIMENSIONS

Material of main body: Iron-based material (FCD450/SS400)

Meter size 15 mm, 20 mm

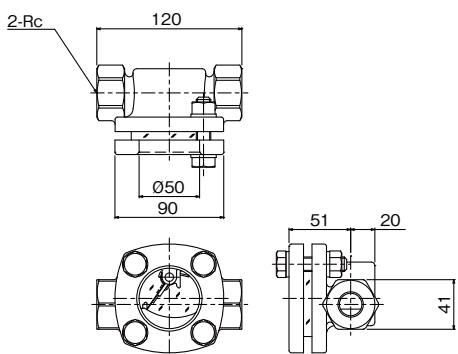

Meter size 25 mm to 50 mm

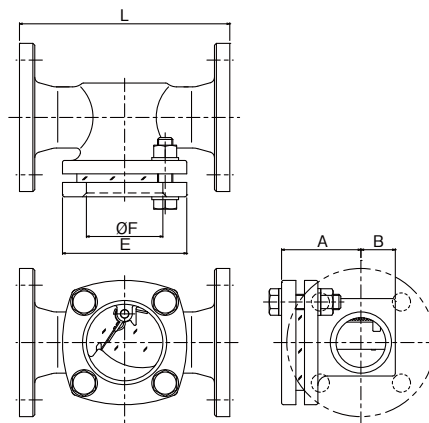

Meter size 65 mm, 80 mm

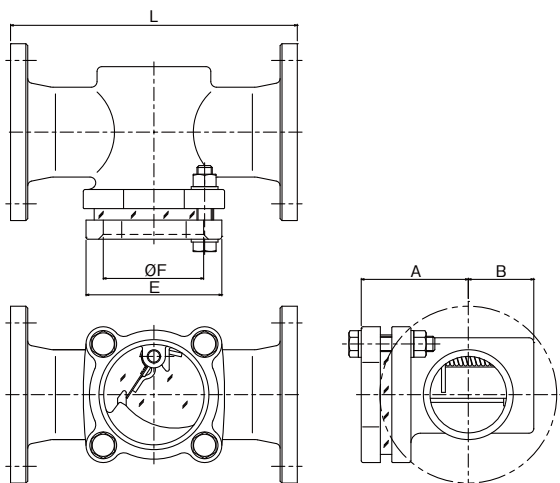

Meter size 100 mm

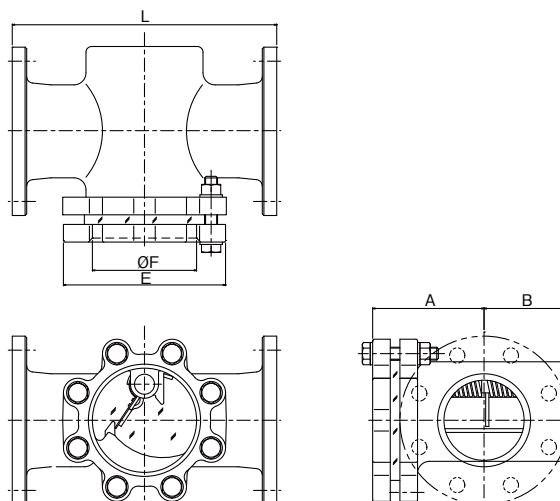

Meter size 125 mm to 300 mm

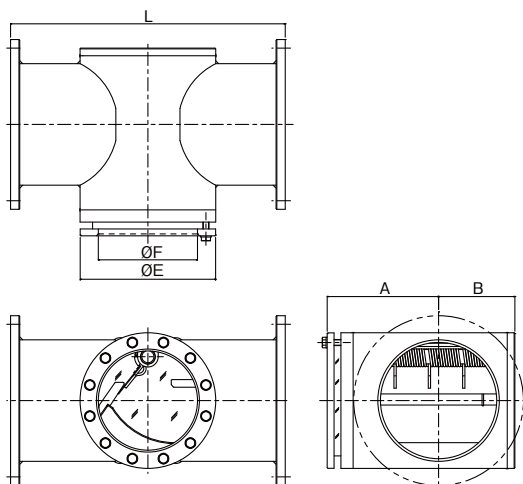

Meter size (mm)	Dimensions (mm)					Weight (Approx.) kg
	L: Face-to-face dimension	A	B	E	F	
15	120	—	—	—	—	2.5
20	120	—	—	—	—	2.5
25	220	61	29	90	50	5.5
32	220	61	29	90	50	6.5
40	220	71	37	130	80	9.0
50	220	83	36	130	80	10.5
65	260	107	64	186	105	14.5
80	300	112	69	186	105	16
100	330	139	105	216	130	26
125	380	162	102	215	130	30
150	480	195	130	267	190	53
200	650	235	150	320	220	80
250	680	258	175	355	260	115
300	720	290	200	355	260	145

Material of main body: Stainless steel (SCS14/SUS304)

Meter size 15 mm, 20 mm

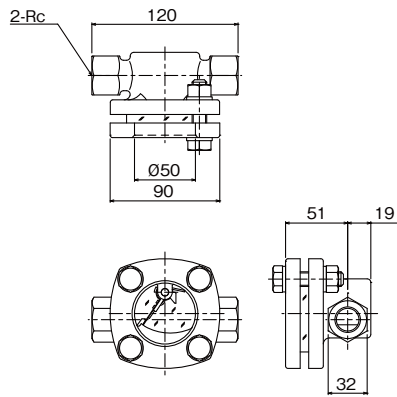

Meter size 25 mm to 50 mm

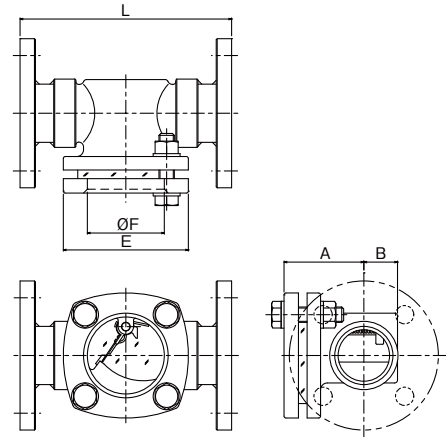

Meter size 65 mm, 80 mm

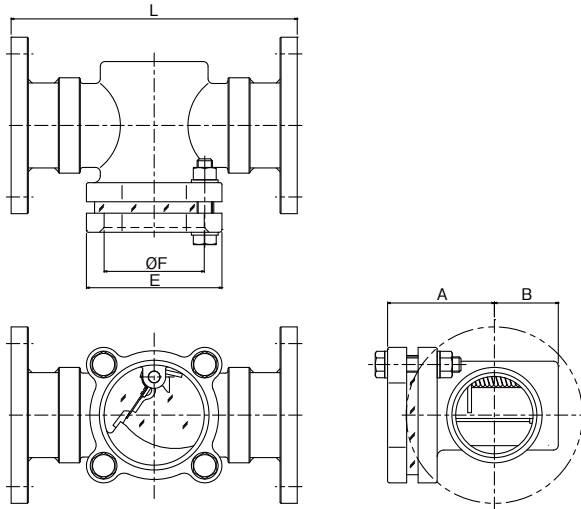

Meter size 100 mm

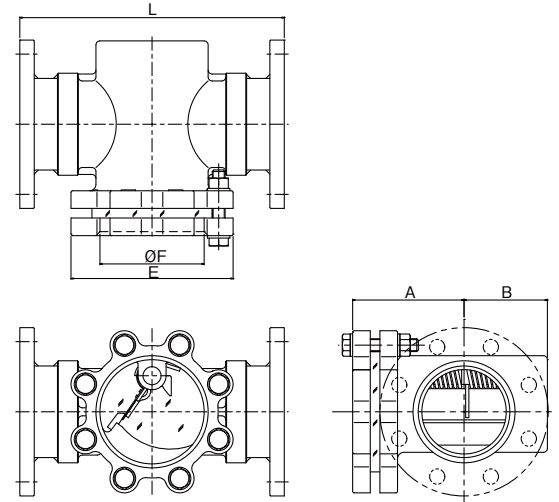

Meter size 125 mm to 300 mm

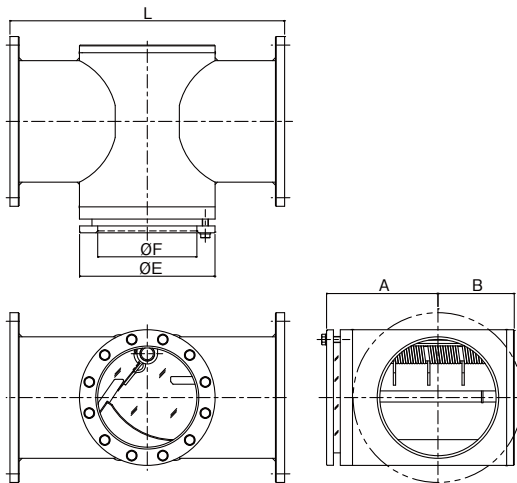

Meter size (mm)	Dimensions (mm)					Weight (Approx.) kg
	L: Face-to-face dimension	A	B	E	F	
15	120	—	—	—	—	2.5
20	120	—	—	—	—	2.5
25	220	61	25	90	50	5.5
32	220	61	29	90	50	6.5
40	220	71	34	130	80	9.0
50	220	83	35	130	80	10.5
65	260	107	62	186	105	14.5
80	300	112	67	186	105	16
100	330	139	104	216	130	26
125	380	162	102	215	130	30
150	480	195	130	267	190	53
200	650	235	150	320	220	80
250	680	258	175	355	260	115
300	720	290	200	355	260	145

## MODEL CODE

STK	400	※	—	※	—	※※※	—	※※※	—	※※	—	P	—	※	/	00	※	※	Specifications			
Function	400																		Sight glass			
Flow direction	1																		Bottom to Top			
	6																		Left to Right			
	7																		Right to Left			
	8																		Top to Bottom			
Material of main body (wetted part)	—	S																	Iron-based material			
	—	4																	Stainless steel			
Meter size	—	015																	15 mm			
	—	020																	20 mm			
	—	025																	25 mm			
	—	032																	32 mm			
	—	040																	40 mm			
	—	050																	50 mm			
	—	065																	65 mm			
	—	080																	80 mm			
	—	100																	100 mm			
	—	125																	125 mm			
	—	150																	150 mm			
	—	200																	200 mm			
—	250																	250 mm				
—	300																	300 mm				
Flow rate range	—	01M																	Range 1	m <sup>3</sup> /h	See Flow rate range code in FLOW RATE RANGE.	
	—	02M																	Range 2			
	—	03M																	Range 3			
	—	04M																	Range 4			
	—	05M																	Range 5			
	—	06M																	Range 6			
	—	07M																	Range 7			
	—	08M																	Range 8			
	—	09M																	Range 9			
	—	10M																	Range 10			
	—	11M																	Range 11			
	—	12M																	Range 12			
	—	01L																	Range 1	L/min		
	—	02L																				Range 2
	—	03L																				Range 3
	—	04L																				Range 4
	—	05L																				Range 5
	—	06L																				Range 6
	—	07L																				Range 7
	—	08L																				Range 8
	—	09L																				Range 9
	—	10L																				Range 10
	—	11L																				Range 11
	—	12L																				Range 12
Process connection	—	RC																	Rc tapered female thread (15 mm: Rc 1/2, 20 mm: Rc 3/4, not available for other meter sizes)			
	—	1F																	JIS 10K FF flange (25 mm to 300 mm)			
	—	1A																	ASME class 150 RF flange (25 mm to 300 mm, only for stainless steel main bodies)			
Packing											—	P							PTFE			
Material of bolts and nuts													—	S						Carbon steel		
													—	4						Stainless steel		
(Fixed code)															/	00				Always 00		
Special specifications																	(Blank)			Not available		
																	/	Z		Available		

\* Specification is subject to change without notice.



Head Office : Shiba Toho Building, 1-7-24 Shibakoen, Minato-ku, Tokyo 105-8558  
 Tel : +81-3-3431-1625 (KEY) ; Fax : +81-3-3433-4922  
 e-mail : overseas.sales@tokyokeiso.co.jp ; URL : http://www.tokyokeiso.co.jp