

OUTLINE

By directly mounting a differential pressure transmitter on the differential- pressure type V-Cone flow sensor the **Integral V-Cone flowmeter** is a compact flowmeter which requires no pressure lead piping and saves much of installation cost.

The V-Cone flowmeter has a V-Cone shaped throttling device developed based on actual fluid experiments. It features self-reshaping the flow profile, stable differential pressure and self-draining.

FEATURES

- **Wide range of applications**
It measures gases, liquids and steam for wide range of application.
- **Short straight runs**
The Required straight runs are less than 1/5 of those required for orifices and vortex flowmeters. The narrow installation space allows simple and flexible piping arrangement to save space and cost.
- **Stable differential pressure signal**
The secondary pressure is measured at the center of the cone, which makes the differential pressure signal stable at as low as 0.025kPa.
- **Wide Rangeability**
Since the differential pressure created by the meter is stable at low flow rate it can measure the flow rate in the range of the turn down ratio 14:1 to cover the wide flow range with the standard differential pressure.
- **Low pressure loss**
The stable measurement at low differential pressure allows low pressure loss which improves energy efficiency of the plant.
- **High reliability**
V-Cone shape has durable structure against wear or adhesion without moving parts. It assures you a long reliable operation without maintenance.

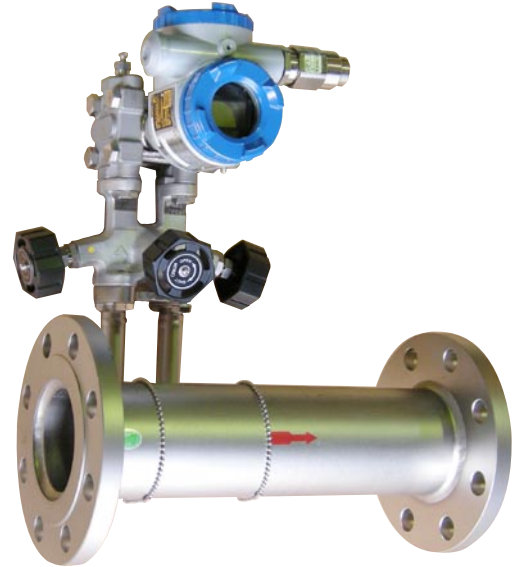

MEASUREMENT PRINCIPLE

The principle of V-Cone flowmeter is the same as that of a common differential pressure type flowmeter, and it is based on the Bernoulli's theorem of the conservation of a fluid energy.

As shown in Fig.1, the pressure P_1 at the approaching point to V-Cone decreases to P_2 at the edge point with increasing fluid velocity by throttling the flow path along the contoured shape of V-Cone. P_1 and P_2 are measured from the pressure taps and the difference of the two pressures is given as:

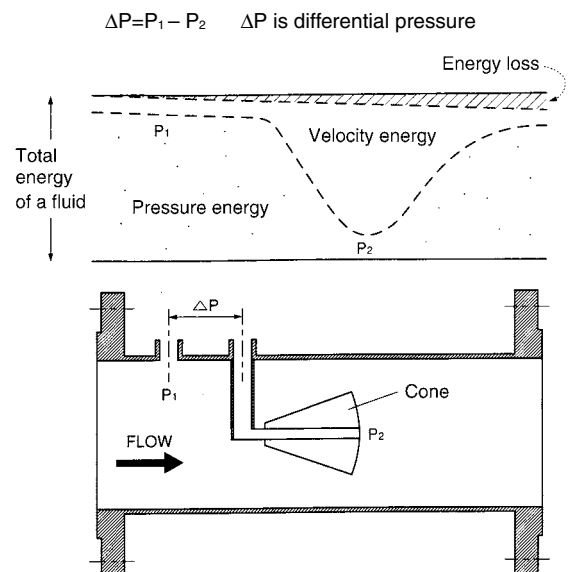

Fig. 1

The following formula explains the relation of flow rate and differential pressure.

$$Q = \frac{3600 \times \pi \times \sqrt{2} \times \beta^2 \times D^2 \times Cd \times \sqrt{\Delta P \times 1000} \times Y}{4 \times \sqrt{\rho} \times \sqrt{(1-\beta^4)}}$$

- Q : Flow rate [m³/h]
- β : Beta ratio
- D : Inside diameter [m]
- Cd : Discharge coefficient
- ΔP : Differential pressure [kPa]
- ρ : Density [kg/m³]

- Y : Gas expansion factor
Y=1-(0.649+0.696×β⁴) × ΔP / (k × P)
- k : Specific heat ratio
- P : Line pressure [kPa]

STANDARD SPECIFICATIONS

- Size : 15mm (1/2inch) to 300mm (12inch)
- Material
 - Body, flange, lead pipe : Stainless steel 304
 - Differential pressure transmitter
 - Diaphragm : SUS316L
 - Other wet parts : SUS316 and PTFE
 - Case and cover : Aluminum alloy
 - 3 valve manifold : SUS316
 - Seal of lead pipe parts : PTFE
 - Sealing liquid of transmitter : Silicone oil
- Process connection : Flanges
JIS 10K RF or ASME Class 150 RF
- Beta ratio : 0.45, 0.50, 0.55, 0.60, 0.65, 0.70, 0.75, 0.80

Fluid temperature and Maximum allowable pressure

Fluids		Steam	Liquid	Gas
Fluid Temperature °C	General type	Max. 190	-40 to 120	-40 to 120
	Flameproof enclosure	Max. 190	-20 to 120	-20 to 120
Maximum allowable pressure MPa		Max. 1.0	Max. 1.4	-0.05 to 0.99

- Ambient temperature
 - General type : -20 to 80°C
 - Flameproof enclosure : -20 to 60°C

Storage temperature : -40 to 90°C

- Accuracy : ±1.5% of Max. flow rate
- Guaranteed Rangeability : 14:1 as standard
- Reynolds No. : ≥ 8000
- Diff. pressure : ≥ 0.025 kPa for gas and liquid
: ≥ 0.05 kPa for steam

Power supply : 10.5 to 45VDC

Output signal : 4 to 20mADC 2-wire

Maximum load : 600Ω at supply voltage 24VDC

● Required straight runs

A [Measuring fluid : Liquids general, both gases and steam with Reynolds No. ≤200,000]

Joints or other obstacles	Upstream	Downstream
1 piece of 90° bend	0D	0D
2 pieces of 90° bend	0D	0D
T joint	0D	0D
Butterfly valve (Flow control valve)	*1	1D
Butterfly valve (Full open)	2D	0D
Gate valve (Full open) or full port ballvalve (Full open)	0D	0D
Expander (Diameter 0.67D expands to 1D, length 2.5D)	2D	1D
Reducer (Diameter 3D reduces to 1D, length 3.5D)	0D	0D

*1: not recommended

B [Measuring fluid : Both Gases and steam with Reynolds No.> 200,000]

Joints or other obstacles	Upstream	Downstream
1 piece of 90° bend	1D	1D
2 pieces of 90° bend	1D	1D
T joint	1D	1D
Butterfly valve (Flow control valve)	*1	1D
Butterfly valve (Full open)	2D	1D
Gate valve (Full open) or full port ballvalve (Full open)	1D	1D
Expander (Diameter 0.67D expands to 1D, length 2.5D)	2D	1D
Reducer (Diameter 3D reduces to 1D, length 3.5D)	0D	0D

*1: not recommended

[Notes]

- D shows the nominal size of V-Cone flowmeter.
- The required straight runs are the distance from the flange faces of V-Cone flowmeter.
- Add 1D to the above mentioned figures for the service β ratio is 0.70 or more.

Differential pressure transmitter

- Flow indication : Digital indication with unit scale on 5 digits LCD
- Enclosure : IP67/JIS C 0920 (equivalent to IEC IP67, NEMA 6/6P)
- Explosionproof : TIIS : Ex do IIB+H₂ T4 (JIS Flameproof type)
Ambient temperature = Max.+60°C
Fluid temperature = Max.+120°C
- Cable connection : G1/2
Use attached explosion proof packing type cable gland suitable for the cable of 11mm outside diameter for the cable connection of the TIIS flameproof construction.
- Connection terminals : M3.5 Screws
- Painting : Polyester resin painting
- Color : Silver case and blue case cover

MODEL CODE

		VD	-																		
Construction		VD																		General type	
	EP	-	VD																	Flameproof enclosure	
Combination *1	1																			V-Cone + Differential pressure transmitter	
	2																			V-Cone + Differential pressure transmitter with degreasing treatment	
	3																			V-Cone + 3 Valve manifold + Differential pressure transmitter	
	4																			V-Cone + 3 Valve manifold + Differential pressure transmitter with degreasing treatment	
Fluid	1																			Steam	
	2																			Liquid	
	3																			Gas	
Connection	1																			JIS 10K RF SO Flange	
	2																			ANSI CLASS 150 RF SO Flange	
	9																			Others	
Flow direction	6																			Left to right, horizontal	
	7																			Right to left, horizontal	
Size	01																			15mm	1/2 inch
	02																			20mm	3/4 inch
	03																			25mm	1 inch
	04																			40mm	1 1/2 inch
	05																			50mm	2 inch
	06																			65mm	2 1/2 inch
	08																			80mm	3 inch
	10																			100mm	4 inch
	13																			125mm	5 inch
	15																			150mm	6 inch
	20																			200mm	8 inch
	25																			250mm	10 inch
30																			300mm	12 inch	
Beta ratio	45																			0.45	
	50																			0.50	
	55																			0.55	
	60																			0.60	
	65																			0.65	
	70																			0.70	
	75																			0.75	
	80																			0.80	

*1 The flowmeter without 3-valve manifold does not allow to dismantle the transmitter from the flowmeter or to make its zero adjustment during operation.

MAXIMUM FLOW RATE RANGE

- Maximum flow rate range at measuring water 20°C

Size		Maximum flow rate (m³/h)	
		Density (kg/m³)	998
15	1/2"	Min.	—
		Max.	(3.47) *1
20	3/4"	Min.	(4.80) *2
		Max.	(6.02) *2
25	1"	Min.	8.55
		Max.	9.64
40	1 1/2"	Min.	13.2
		Max.	22.7
50	2"	Min.	16.9
		Max.	37.4
65	2 1/2"	Min.	20.1
		Max.	54.1
80	3"	Min.	25.0
		Max.	83.5
100	4"	Min.	32.8
		Max.	144
125	5"	Min.	41.1
		Max.	226
150	6"	Min.	49.4
		Max.	326
200	8"	Min.	65.0
		Max.	558
250	10"	Min.	103
		Max.	879
300	12"	Min.	147
		Max.	1245

REMARKS

- Flow rates shown in the each table indicate the maximum flow rate range in which the accuracy is guaranteed at each size and at prescribed pressure or density. The minimum flow rate within the range of which the accuracy is guaranteed is 1/14 of the maximum flow rate with the exceptions of figures in parenthesis as noted.

- Contact TOKYO KEISO Co., Ltd. for the detail information about sizing.

*1 Accuracy guaranteed flow range is 9 : 1.

*2 Accuracy guaranteed flow range is 10 : 1.

- Maximum flow rate range at measuring air at 20°C and following pressure

Size		Maximum flow rate (m³/h(nor))										
		Pressure (Gage)	0.1MPa	0.2MPa	0.3MPa	0.4MPa	0.5MPa	0.6MPa	0.7MPa	0.8MPa	0.9MPa	0.99MPa
		Density(kg/m³)	2.393	3.582	4.771	5.960	7.149	8.337	9.526	10.715	11.904	12.974
15	1/2"	Min.	71	71	71	71	71	71	71	71	71	71
		Max.	91	137	177	199	220	238	256	272	287	301
20	3/4"	Min.	93	93	93	93	93	93	93	93	93	93
		Max.	159	238	306	346	381	414	444	472	498	521
25	1"	Min.	119	119	119	119	119	119	119	119	119	119
		Max.	254	381	491	554	610	662	710	755	798	834
40	1 1/2"	Min.	184	182	182	182	182	186	199	211	222	232
		Max.	599	898	1156	1304	1438	1560	1673	1779	1879	1964
50	2"	Min.	161	233	233	255	280	302	323	343	362	377
		Max.	987	1481	1905	2150	2370	2571	2758	2933	3097	3239
65	2 1/2"	Min.	229	282	325	364	399	431	461	489	516	538
		Max.	1427	2140	2754	3108	3426	3716	3986	4239	4477	4681
80	3"	Min.	354	434	502	562	616	666	712	755	796	831
		Max.	2204	3306	4253	4800	5291	5740	6156	6546	6914	7230
100	4"	Min.	609	748	865	968	1061	1147	1226	1301	1371	1432
		Max.	3798	5697	7330	8272	9117	9891	10609	11281	11915	12458
125	5"	Min.	957	1175	1359	1520	1666	1800	1925	2042	2153	2248
		Max.	5965	8946	11512	12991	14319	15534	16661	17716	18712	19566
150	6"	Min.	1382	1697	1963	2196	2407	2601	2781	2951	3111	3248
		Max.	8620	12927	16633	18770	20689	22444	24073	25598	27037	28270
200	8"	Min.	2419	2971	3436	3844	4214	4553	4869	5165	5446	5686
		Max.	14723	22080	28410	32060	35337	38336	41118	43723	46181	48287
250	10"	Min.	3813	4684	5416	6060	6642	7177	7675	8142	8584	8964
		Max.	23210	34807	44786	50541	55706	60434	64818	68925	72800	76120
300	12"	Min.	5470	6718	7768	8692	9527	10294	11008	11679	12313	12857
		Max.	32859	49277	63405	71552	78865	85558	91765	97578	103065	107765

● Maximum flow rate range at measuring saturated steam

Size		Maximum flow rate (kg/h)										
		Pressure (Gage)	0.1MPa	0.2MPa	0.3MPa	0.4MPa	0.5MPa	0.6MPa	0.7MPa	0.8MPa	0.9MPa	1.0MPa
		Density (kg/m ³)	1.131	1.658	2.169	2.676	3.176	3.673	4.169	4.662	5.153	5.644
15	1/2"	Min.	65	67	69	70	71	72	73	74	75	76
		Max.	79	117	153	172	189	204	218	232	244	256
20	3/4"	Min.	86	89	91	93	94	95	97	98	99	100
		Max.	137	202	266	299	328	354	379	402	423	444
25	1"	Min.	109	113	115	118	119	121	123	125	125	127
		Max.	219	324	426	478	525	567	606	643	678	711
40	1 1/2"	Min.	168	173	177	191	209	224	239	253	266	279
		Max.	516	763	1004	1127	1236	1336	1428	1515	1596	1673
50	2"	Min.	215	243	279	311	339	365	390	412	434	454
		Max.	851	1259	1656	1858	2038	2202	2355	2497	2631	2759
65	2 1/2"	Min.	284	347	398	444	484	521	556	588	618	648
		Max.	1230	1819	2393	2685	2946	3183	3404	3609	3803	3988
80	3"	Min.	439	535	615	685	747	805	858	908	955	1000
		Max.	1899	2810	3696	4147	4549	4916	5256	5574	5874	6158
100	4"	Min.	756	922	1060	1180	1287	1386	1478	1564	1645	1722
		Max.	3273	4842	6369	7147	7840	8472	9058	9606	10122	10613
125	5"	Min.	1186	1448	1664	1852	2021	2176	2321	2456	2583	2705
		Max.	5141	7605	10003	11224	12312	13306	14226	15086	15897	16667
150	6"	Min.	1714	2092	2403	2676	2920	3144	3353	3548	3732	3908
		Max.	7428	10989	14453	16218	17790	19225	20555	21798	22969	24082
200	8"	Min.	3000	3662	4207	4684	5112	5504	5869	6211	6533	6840
		Max.	12687	18770	24687	27701	30386	32838	35109	37232	39233	41133
250	10"	Min.	4729	5773	6632	7384	8058	8677	9251	9790	10299	10783
		Max.	20001	29589	38916	43668	47901	51766	55346	58693	61847	64842
300	12"	Min.	6782	8280	9512	10591	11558	12445	13269	14042	14772	15466
		Max.	28315	41889	55095	61821	67815	73287	78354	83093	87558	91798

DIMENSIONS

● Fig. "a" Steam and liquids

15mm to 40mm or 1/2 inch to 1 1/2 inch
Flow direction : Left to right or Right to left

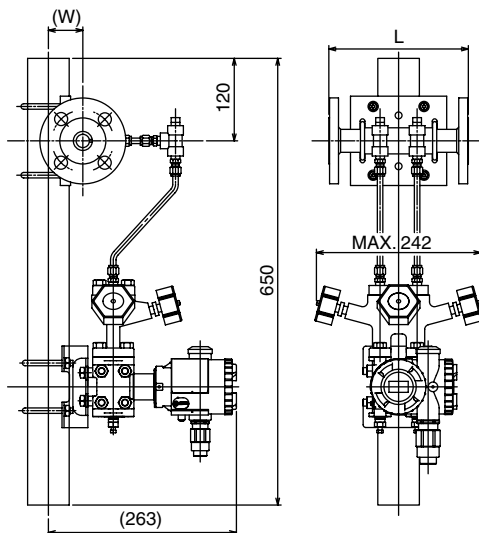

● Fig. "b" Gases

15mm to 40mm or 1/2 inch to 1 1/2 inch
Flow direction : Left to right or Right to left

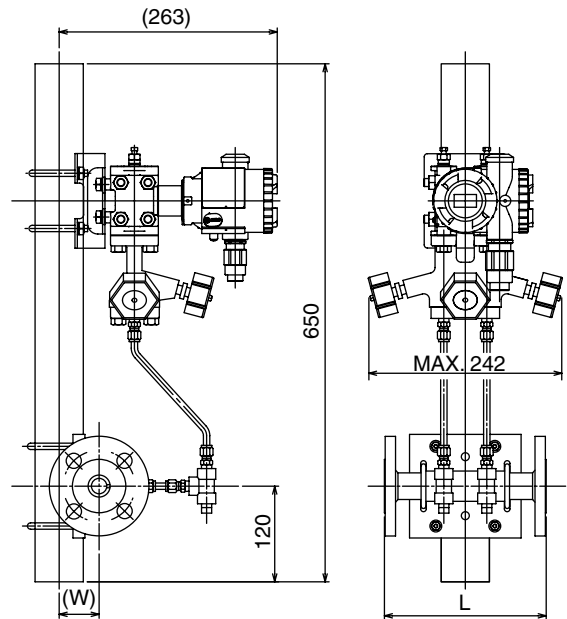

● Fig. "c" Steam and liquids 50mm to 300mm or 2 inch to 12 inch

Flow direction : Left to right

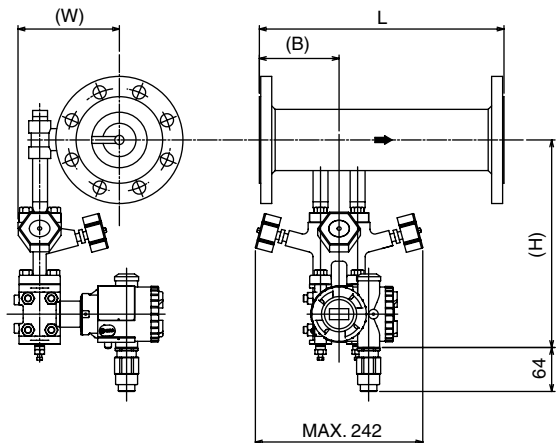

Flow direction : Right to left

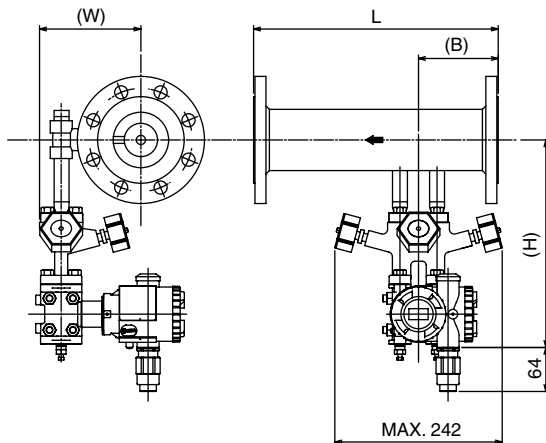

● Fig. "d" Gases 50mm to 300mm or 2 inch to 12 inch

Flow direction : Left to right

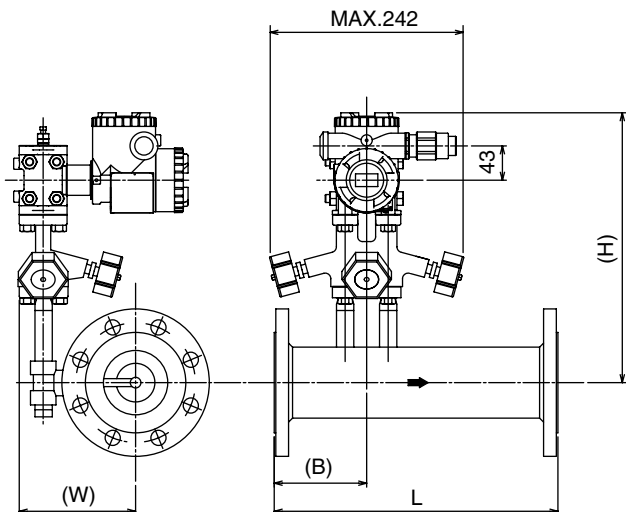

Flow direction : Right to left

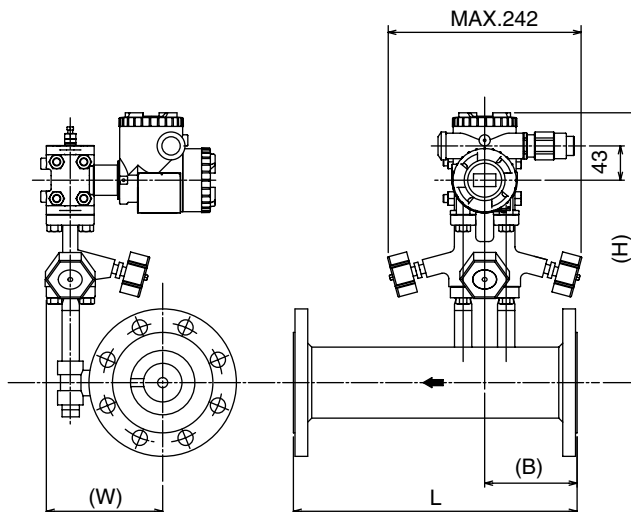

Note: An explosionproof packing type cable gland mounted on cable entry as shown in above drawings is delivered only for flameproof construction.

Size	L (mm)	(B) (mm)	(W) (mm)	(H) (mm)				Figures	Mass kg *1
				With 3 Valve manifold		Without 3 Valve manifold			
				Steam and Liquids	Gases	Steam and Liquids	Gases		
15mm 1/2"	203	-	44	-	-	-	-	a, b	18
20mm 3/4"	203	-	47	-	-	-	-	a, b	19
25mm 1"	203	-	50	-	-	-	-	a, b	20
40mm 1 1/2"	254	-	57	-	-	-	-	a, b	22
50mm 2"	305	116	132	287	323	197	233	c, d	19
65mm 2 1/2"	305	116	138	295	331	205	241	c, d	22
80mm 3"	356	116	146	302	338	212	248	c, d	23
100mm 4"	406	129	174	327	363	237	273	c, d	28
125mm 5"	559	135	187	342	378	252	288	c, d	42
150mm 6"	559	135	201	352	388	262	298	c, d	46
200mm 8"	660	154	241	387	423	297	333	c, d	75
250mm 10"	711	154	268	412	448	322	358	c, d	89
300mm 12"	762	160	294	437	473	347	383	c, d	108

*1 The figures show the mass of flowmeter with JIS 10K RF SO flanges.

* Specification is subject to change without notice.

TIV TOKYO KEISO CO., LTD.

Head Office : Shiba Toho Building, 1-7-24 Shibakoen, Minato-ku, Tokyo 105-8558

Tel : +81-3-3431-1625 (KEY) ; Fax : +81-3-3433-4922

e-mail : overseas.sales@tokyokeiso.co.jp ; URL : http://www.tokyokeiso.co.jp

