



# TECHNICAL GUIDANCE

FOR THE MASS FLOW CONTROL OF ALL KINDS OF GASES

## TC Series

THERMAL MASS FLOW CONTROLLER

### OUTLINE

TC series are thermal mass flow controllers, a combination of thermal mass flowmeter and control valve.

TC automatically controls the mass flow rate of various kinds of gases with high accuracy. General purpose of TC-1000 up to 0.99MPa and high pressure version of TC 2000 up to 10MPa are available.

### FEATURES

- ❑ WIDE FLOW RANGE
  - Minimum 0 to 5mL/min(nor), Maximum 0 to 500L/min(nor) (0 to 50mL/min(nor) to 0 to 100L/min(nor) for High pressure version)
- ❑ HIGH ACCURACY
  - ±1% F.S. control accuracy.
- ❑ QUICK RESPONSE
  - 3 sec. response for 98%
- ❑ FREE FROM PRESSURE AND TEMPERATURE VARIATION Negligible ZERO and SPAN drift for pressure and temperature.
- ❑ HIGH RELIABILITY
  - Special stainless steel with high anti-corrosive capability is used for solenoid valve actuator. Durable for long time operation.
- ❑ HIGH FUNCTION
  - Theoretically, Mass flow measurement.

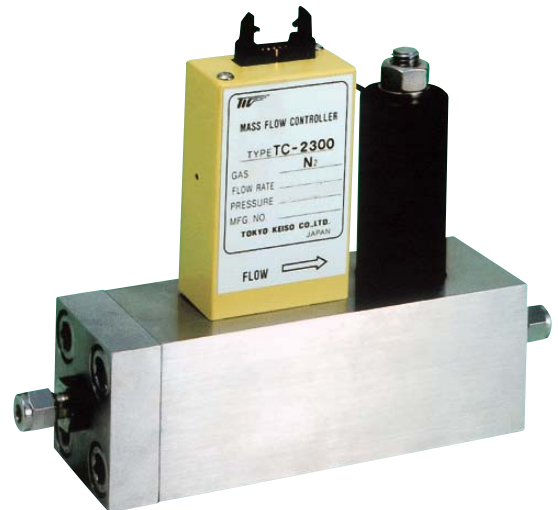

Then, the bridge circuit outputs electric signal. Theoretically, the heat transfer is proportional to the moving mass of the gas to be measured and its specific heat. The specific heat of the gas is not affected by its pressure and within reasonable range of temperature, it can be observed to be as stable.

Thus, by measuring the heat transfer through bridge output, the mass flow rate of the gas can be measured. The output signal from the bridge circuit is amplified to 0 to 5 V DC and sent to indicator and as comparison circuit. At the comparison circuit, the output is compared to the external setting signal. The control valve is actuated to open or to close to make the output and setting signal equal. The control valve has an electromagnetic type actuator for Normal close action.

### OPERATION PRINCIPLE

The gas to be measured is directed to by-pass sensing path by flow restriction. At the by-pass sensing path, two resistance coils are wound which consist a bridge circuit with resistance circuit in electric compartment.

In case of no flow passing through the by-pass sensing path, the bridge circuit is in balanced condition.

When the gas moves, the heat at the upstream coils is transferred to downstream coil and thus upsetting the original heat balance.

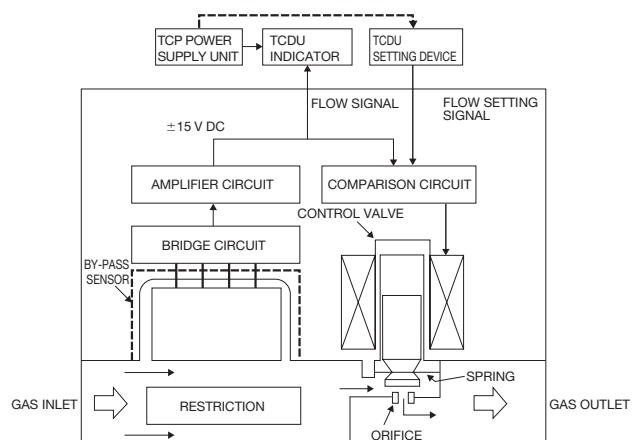

# TC-1000 GENERAL PURPOSE THERMAL MASS FLOW CONTROLLER

## MODEL CODE

TC-1  -  -  - GAS

FLOW RANGE	100			MAX 10L/min(nor)	
	200			MAX 20L/min(nor)	
	300			MAX 80L/min(nor)	
	350			MAX 100L/min(nor)	
	400			MAX 300L/min(nor)	
	550			MAX 500L/min(nor)	
FULL SCALE	050			5mL/min(nor)	TC-1100
	100			10mL/min(nor)	
	200			20mL/min(nor)	
	300			30mL/min(nor)	
	500			50mL/min(nor)	
	101			100mL/min(nor)	
	201			200mL/min(nor)	
	301			300mL/min(nor)	
	501			500mL/min(nor)	
	102			1L/min(nor)	
	202			2L/min(nor)	TC-1200
	302			3L/min(nor)	
	502			5L/min(nor)	
	103			10L/min(nor)	
	153			15L/min(nor)	TC-1300
	203			20L/min(nor)	
	303			30L/min(nor)	
	503			50L/min(nor)	
	703			70L/min(nor)	TC-1350
	803			80L/min(nor)	
104			100L/min(nor)	TC-1400	
154			150L/min(nor)		
204			200L/min(nor)		
254			250L/min(nor)	TC-1550	
304			300L/min(nor)		
404			400L/min(nor)		
504			500L/min(nor)		
CONNECTION	P		Rc		
	N		NPT		
	S		SW		
	R		VCR		
	O		VCO		
CONNECTION SIZE	04		1/4"	TC-1100, 1200	
	06		3/8"	TC-1300, 1350	
	08		1/2"	TC-1400	
	12		3/4"	TC-1400, 1550	
	16		1"		

## STANDARD SPECIFICATIONS

TYPE	TC-1100	TC-1200
FLOW RANGE (FULL SCALE)	5mL/min(nor) to 10L/min(nor)	10 to 20L/min(nor)
FLOW CONTROL RANGE		
RESPONSE TIME (98% RESPONSE)		
FLOW RATE OUTPUT SIGNAL		
SETTING SIGNAL		
ACCURACY		
CONTROL ΔP(MPa)	0.06 to 0.3	0.06 to 0.3
MAX. GAS PRESS.(MPa)		
GAS. TEMP		
TEMP.DRIFT		
PRESS.DRIFT		
POWER SUPPLY	+15 V DC 25mA Max. -15 V DC 200mA Max.	
GAS CONTACT MATERIAL		
CONNECTION	Rc1/4, OD1/4SW, VCR, VCO	
MASS(kg)	1.1	1.4

## DIMENSION

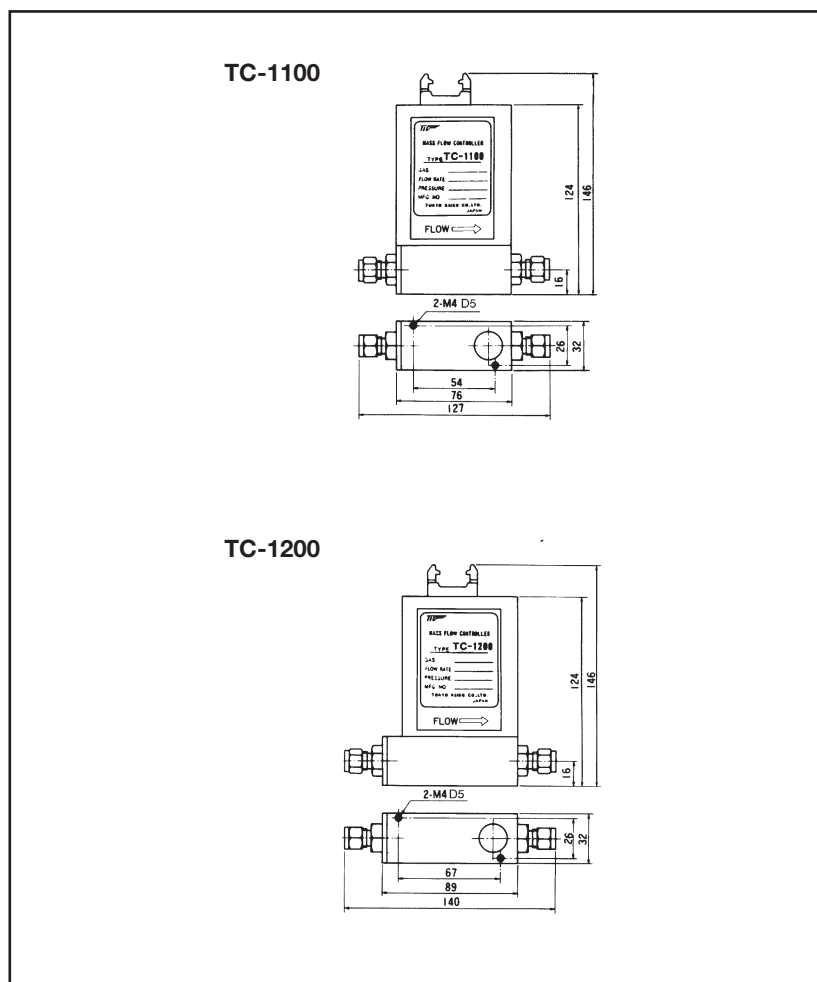

TC-1300		TC-1350		TC-1400			TC-1550	
20 to 80L/min(nor)		80 to 100L/min(nor)		100 to 150L/min(nor)	150 to 200L/min(nor)	200 to 300L/min(nor)		300 to 500L/min(nor)
2 to 100% OF FULL SCALE								
WITHIN 3 sec.						WITHIN 4 sec.		
0 to 5 V DC								
0 to 5 V DC								
±1%F.S.(at 25°C)								
0.07 to 0.3		0.1 to 0.45		0.12 to 0.35	0.15 to 0.35		0.18 to 0.5	
0.99								
5 to 50°C								
SPAN ±0.1%F.S./°C Max. ZERO ±0.05%F.S./°C Max.								
0.25%F.S. (WITHIN OPERATING PRESSURE RANGE)								
+15 V DC 25mA Max. -15 V DC 320mA Max.						+15 V DC 25mA Max. -15 V DC 200mA Max.		
SUS316, SHOMAC* <sup>2</sup> , PTFE, FKM or CR								
OD 3/8SW, VCR, VCO		Rc3/4, 1, OD 1/2, 3/4 SW					Rc 3/4, 1	
2.0	3.2	6.0					6.2	

\*(1) Flow rate with Nitrogen. Refer to MODEL CODE for details

\*(2) Ferrite Stainless Steel material

TC-1300

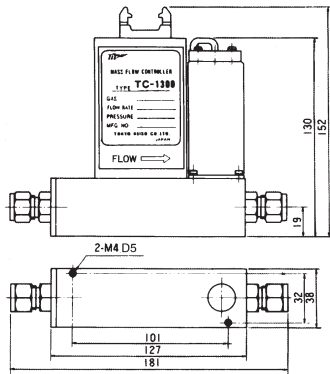

TC-1350

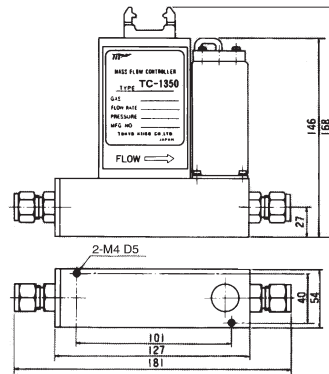

TC-1400

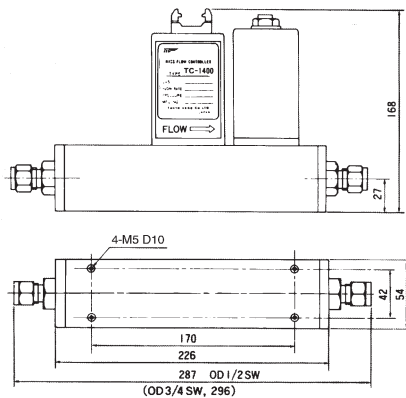

TC-1550

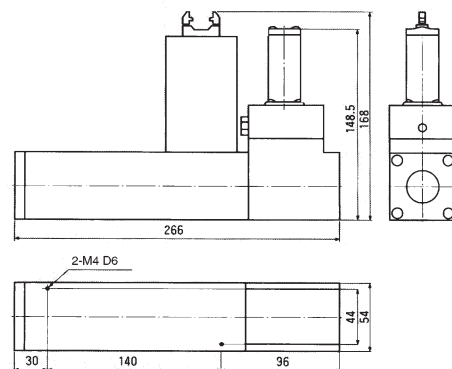

# TC-2000 HIGH PRESSURE THERMAL MASS FLOW CONTROLLER

## MODEL CODE

## STANDARD SPECIFICATIONS

TC-2  -  -  - GAS

FLOW RANGE	100			MAX 10L/min(nor)	
	200			MAX 20L/min(nor)	
	300			MAX 100L/min(nor)	
FULL SCALE	500			50mL/min(nor)	TC-2100
	101			100mL/min(nor)	
	201			200mL/min(nor)	
	301			300mL/min(nor)	
	501			500mL/min(nor)	
	102			1L/min(nor)	
	202			2L/min(nor)	TC-2200
	302			3L/min(nor)	
	502			5L/min(nor)	
	103			10L/min(nor)	
	153			15L/min(nor)	TC-2300
	203			20L/min(nor)	
	303			30L/min(nor)	
	503			50L/min(nor)	
703			70L/min(nor)		
803			80L/min(nor)		
104			100L/min(nor)		
CONNECTION	P			Rc	
	N			NPT	
	S			SW	
CONNECTION SIZE	04			1/4"	TC-2100/TC-2200
	06			3/8"	TC-2300

MODEL	TC-2100	TC-2200	TC-2300
FLOW RANGE*(1) (FULL SCALE)	50mL/min(nor) to 10L/min(nor)	10 to 20 L/min(nor)	20 to 100 L/min(nor)
FLOW CONTROL RANGE	2 to 100% OF FULL SCALE		
RESPONSE TIME	WITHIN 3 sec. (98% RESPONSE)		
FLOW RATE OUTPUT SIGNAL	0 to 5 V DC		
SETTING INPUT SIGNAL	0 to 5 V DC		
ACCURACY	±1%F.S. (at 25°C)		
MAX. GAS PRESS. (MPa)	10MPa*(2)		
CONTROL ΔP	50 to 80% of Primary pressure		
GAS. TEMP.	5 to 50C		
TEMP. DRIFT	SPAN	±0.1%F.S./°Cmax	
	ZERO	±0.05%F.S./°Cmax	
PRESS DRIFT	±0.1%F.S./ (0.1MPa)max (on N <sub>2</sub> gas) *(3)		
POWER SUPPLY	+15 V DC 25mA -15 V DC 320mA		
GAS CONTACT	SUS316, SHOMAC® *(4), PTFE, FKM or CR		
CONNECTION	SIZE	OD 1/4	OD 3/8
	TYPE	Swagelok, Rc (=PT), NPT	

- \*(1) Flow rate with Nitrogen. In case of measurement of hydrogen (H<sub>2</sub>) Minimum flow range will be 250mL/min(nor).
- \*(2) Make the flow calibration by the actual pressure for the operating pressure up to 9.8MPa. When exceeding 9.8MPa, conduct the pressure test and flow calibration by the pressure conversion, based on the operating pressure. There is the limit in the maximum operating pressure, depending on gas. (Reference: CO<sub>2</sub> gas is available up to 3MPa. Otherwise it liquefies.)
- \*(3) The pressure effect varies with the operating pressure and kind of fluid when the pressure exceeds 1 MPa.
- \*(4) Ferrite Stainless Steel material

## DIMENSION

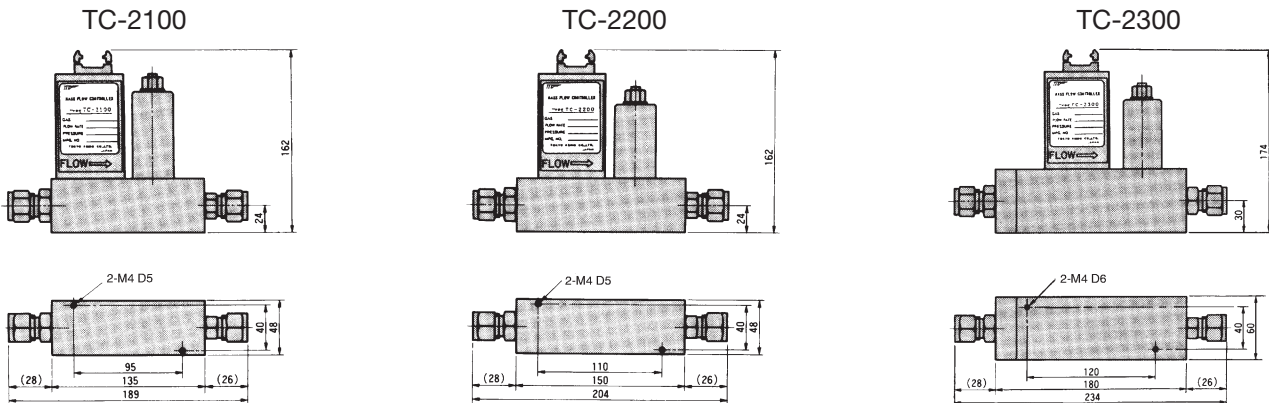

**SUPPORTING INSTRUMENTS**

□ EXCLUSIVE CABLES

Connection cables are available as follows. Cable ends are properly terminated for immediate connection to devices.

TYPE OF CABLE	USAGE	STANDARD LENGTH
SC-T	TC-1000/TC-2000 ↔ TCP	2m
SC-DS	TCP ← TCSU TCDU	2m
SC-CM-□□	TC-1000/TC-2000 ↔ TM-1400	2m (Max.100m)

□ TCP POWER SUPPLY UNIT

TCP supplies necessary power to TC Controller and TCDU indicator. Also, TCP scales the output from TC controller and feeds to TCDU to indicate flow rate in actual scale.

TYPE	TCP-1	TCP-3	TCP-5
POWER SUPPLY FOR TC-1000/2000	+15V 100mA -15V 350mA	FOR 3 LOOPS	FOR 5 LOOPS
POWER SUPPLY FOR TDCU	+5V 200mA		
FLOW SETTING OUTPUT	+5V ± 0.1%		
POWER SUPPLY	100 V AC ± 10% 50/60Hz		
DIMENSION	60×100×120	140×100×144	226×100×144

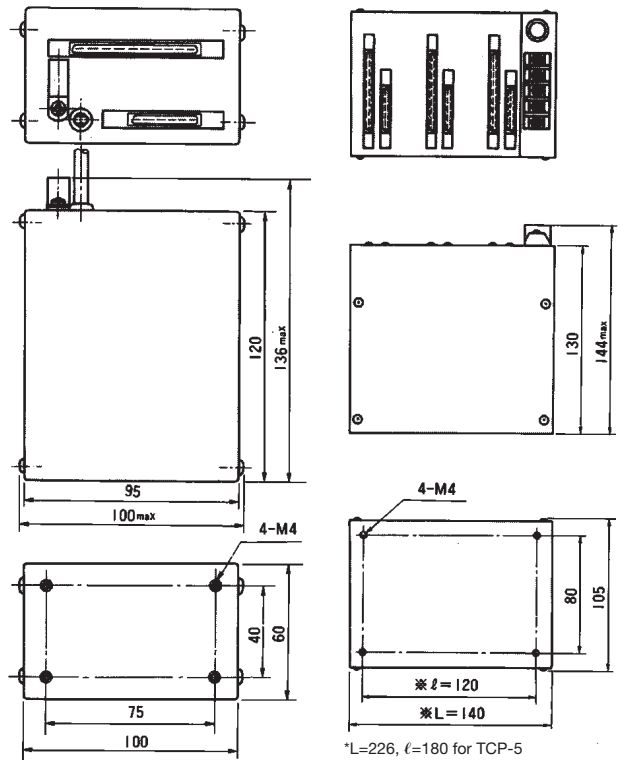

TCP-1

TCP-3

□ TCDU INDICATOR

TCDU is a "Digital Panel Meter" with 3 1/2 digit indication. Flow rate of the gas is indicated actual industrial unit such as L/min(nor).

MODEL	TCDU-8
INDICATION	3 1/2 digit
DIGIT HEIGHT	8mm
POWER SUPPLY	+5V 100mA

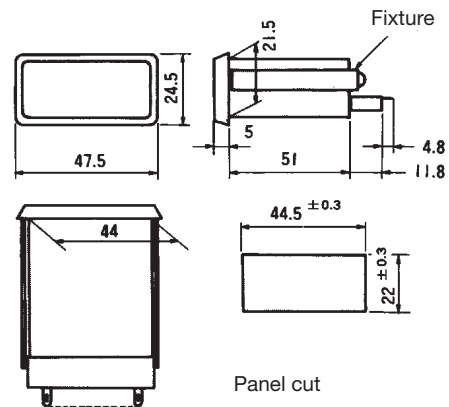

Panel cut

□ TCSU SETTING DEVICE

TCSU is a potention-meter with 2 digit setting counter. Flow rate can be set with 1/100 resolvability.

MODEL	TCSU
SPECIFICATION	Potention-Meter with 2 digit setting counter
RESISTANCE	10kΩ / 10 rotation

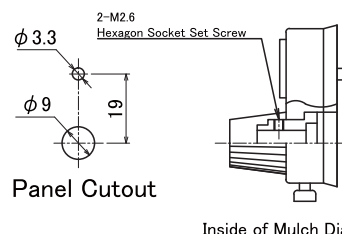
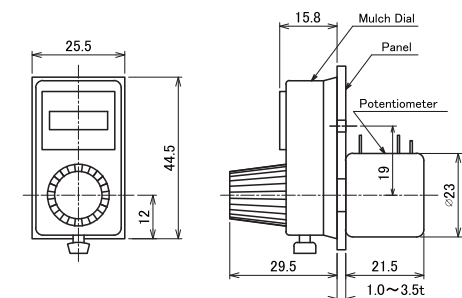

Panel Cutout

Inside of Mulch Dial

**TM-1400 CONVERTER UNIT**

TM-1400 MINI CONVERTER UNIT is power supply and indication unit which is used in combination with Tokyo Keiso's TC-1000, 2000 series mass flow controllers.

All necessary functions of power supply to the mass flow controllers and scaling indication of flow signal, and flow rate setting function with the change of external/manual setting are provided in DIN 72mm compact housing.

Additionally, totalizing pulse output is provided as option for easy composition of the flow-rate regulating system of various gases.

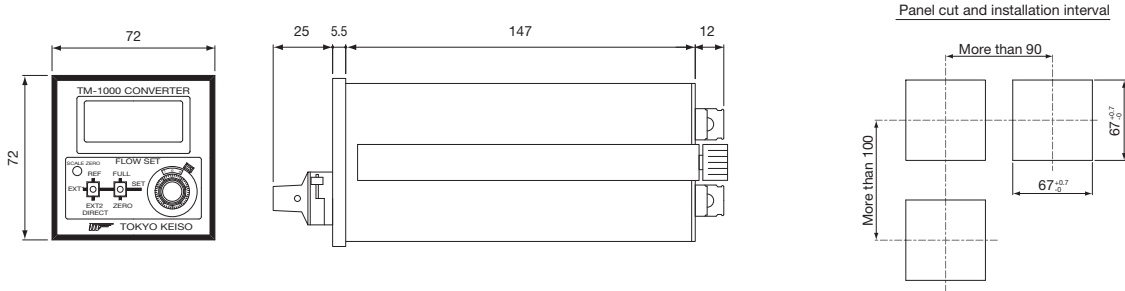

**SYSTEM CONFIGURATION**

By using separate units

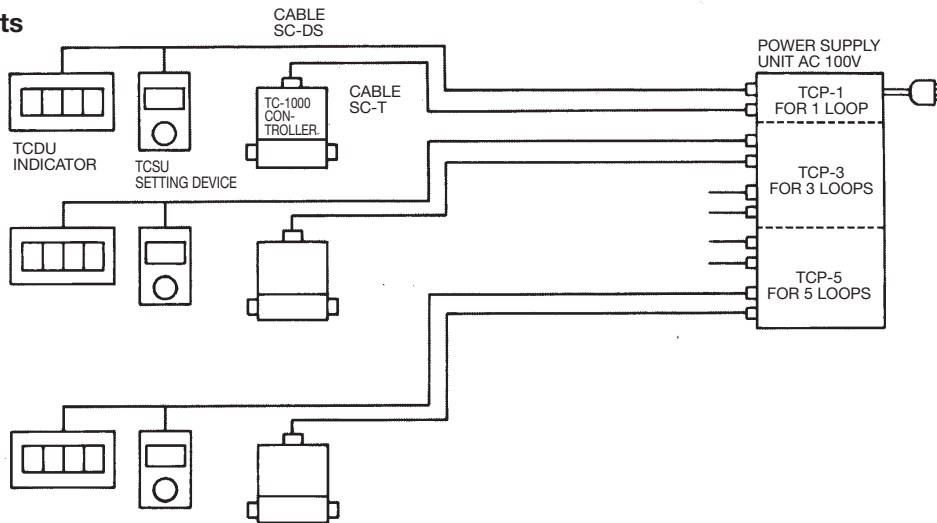

**With TM-1400 CONVERTER UNIT**

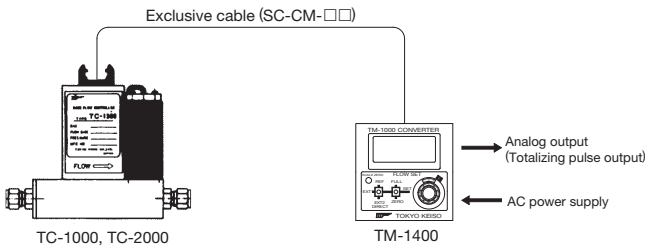

**PROPORTIONAL MIXING PROCESS**

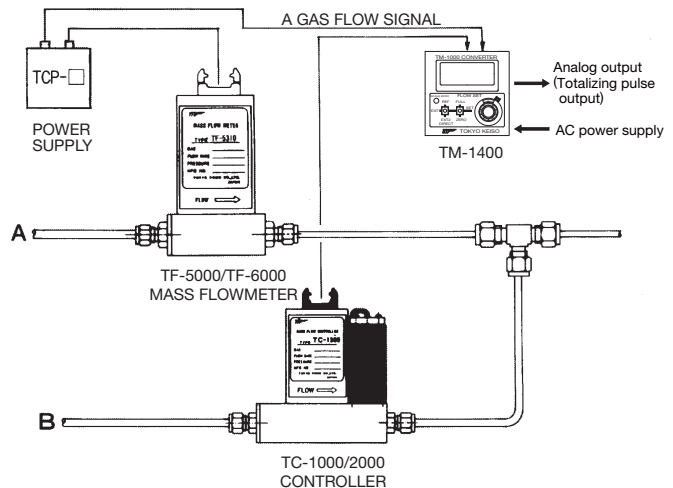

## EXAMPLE OF MODEL SELECTION

The flow range is indicated on the basis of N<sub>2</sub> gas.

When measuring the gases other than N<sub>2</sub> gas, refer to the conversion factor (CF) shown below, and check if the flow rate converted into the flow rate of N<sub>2</sub> gas is acceptable for the desired model.

### Formula for single ingredient gas (only one kind of gas)

$$\text{Flow to select the model (Converted to N}_2\text{ gas)} = \frac{\text{Max gas flow range}}{\text{CF}}$$

### Formula for mixed gas (more than 2 kinds of gas)

In case of the mixed gas, calculate CF of the mixed gas, and then make N<sub>2</sub> conversion as well as single ingredient gas.

$$\text{CF of the mixed gas} = \frac{1}{\frac{X1}{CF1} + \frac{X2}{CF2} + \dots + \frac{X6}{CF6}}$$

X1 : Composition ratio of 1 ingredient (VOL%/100)

X2 : Composition ratio of 2 ingredient (VOL%/100)

⋮

X6 : Composition ratio of 6 ingredient (VOL%/100)

CF1 : CF of 1 ingredient

CF2 : CF of 2 ingredient

⋮

CF of 6 ingredient

$$\text{Flow to select the model (Converted to N}_2\text{ gas)} = \frac{\text{Max gas flow range}}{\text{CF of mixed gas}}$$

CF of main gases

Fluid	Molecular formula	CF	Fluid	Molecular formula	CF
Nitrogen	N <sub>2</sub>	1.000	Nitrogen dioxide	NO <sub>2</sub>	0.740
Air	Air	1.001	Dinitrogen monoxide	N <sub>2</sub> O	0.714
Argon	Ar	1.2 <sup>※a</sup>	Oxygen	O <sub>2</sub>	0.984
Carbon monoxide	CO	0.998	Methane	CH <sub>4</sub>	0.782
Carbon dioxide <sup>※b</sup>	CO <sub>2</sub>	0.745	Ethylene	C <sub>2</sub> H <sub>4</sub>	0.623
Helium	He	1.404	Ethane	C <sub>2</sub> H <sub>6</sub>	0.505
Hydrogen	H <sub>2</sub>	1.007	Propylene	C <sub>3</sub> H <sub>6</sub>	0.407
Neon	Ne	1.403	Propane	C <sub>3</sub> H <sub>8</sub>	0.351
Ammonia	NH <sub>3</sub>	0.769	n-butane	n-C <sub>4</sub> H <sub>10</sub>	0.266
Nitric monoxide	NO	0.976			

※a : N<sub>2</sub> conversion of Ar is 1.2, but it is 1.4 when correcting the gas based on CF.

※b : Service limit for CO<sub>2</sub> is 3MPa (TC-2000 Series). When the pressure reaches the limit, keep the gas temperature at 30°C or higher.

Example: Fluid; Helium, Flow: 25L/min(nor), Pressure: 0.1MPa, Temperature: 20°C, Fitting:1/4"SWL:-

$$\text{Converted flow to N}_2\text{ gas} = \frac{25\text{L/min (nor)}}{1.404 \text{ (CF)}} = 17.8$$

The converted flow to N<sub>2</sub> gas is 17.8, and the model to be selected is TC-1200-203-S04.

## CAUTION ON USE

- Install the unit horizontally with its connector facing upwards.
- The primary pressure should be the same as the operating pressure as specified in the inquiry.
- Install the unit so that the arrow on the unit matches the flow direction of fluid.

**ORDERING INFORMATION**

Specify the following for order/inquiry

THERMAL MASS FLOW CONTROLLER

TYPE	TC-□□□□-□□□□-□□□□				
GAS TO BE MEASURED					
PRIMARY PRESS.	MAX.	MPa	Nor.	MPa	Min. MPa
DIFFERENTIAL PRESS.	to				MPa
TEMP.	°C				
FULL SCALE			<input type="checkbox"/> mL/min(nor)	<input type="checkbox"/> L/min(nor)	
CONNECTION SIZE	<input type="checkbox"/> 1/4"	<input type="checkbox"/> 3/8"	<input type="checkbox"/> 1/2"	<input type="checkbox"/> 3/4"	<input type="checkbox"/> 1"
CONNECTION TYPE	<input type="checkbox"/> Swagelok	<input type="checkbox"/> Rc (=PT)	<input type="checkbox"/> NPT	<input type="checkbox"/> VCR	<input type="checkbox"/> VCO

SUPPORTING INSTRUMENTS

POWER SUPPLY UNIT	<input type="checkbox"/> TCP-1	<input type="checkbox"/> TCP-3	<input type="checkbox"/> TCP-5	<input type="checkbox"/> Not required
INDICATOR	<input type="checkbox"/> TCDU-8	<input type="checkbox"/> Not required		
SETTING DEVICE	<input type="checkbox"/> TCSU	<input type="checkbox"/> Not required		
CONVERTER	<input type="checkbox"/> TM-14	<input type="checkbox"/> □□ - □□□ (Indication+Setting)	<input type="checkbox"/> Not required	
EXCLUSIVE CABLE	SC-DS	<input type="checkbox"/> STD. 2m	<input type="checkbox"/> _____ m (Max.20m)	
	SC-T	<input type="checkbox"/> STD. 2m	<input type="checkbox"/> _____ m (Max.100m)	
	SC-CM-□□	<input type="checkbox"/> STD. 2m	<input type="checkbox"/> _____ m (Max.100m)	

\* Specification is subject to change without notice.



Head Office : Shiba Toho Building, 1-7-24 Shibakoen, Minato-ku, Tokyo 105-8558  
 Tel : +81-3-3431-1625 (KEY) ; Fax : +81-3-3433-4922  
 e-mail : overseas.sales@tokyokeiso.co.jp ; URL : http://www.tokyokeiso.co.jp