



TECHNICAL GUIDANCE

Standard type purgometer for measuring gases and liquids in semiconductor production

P-820 Purgometer

OUTLINE

Just like the popular P-810 model, the P-820 is also widely used in semiconductor production. Models with reed switch type alarm contact are available.

MAJOR APPLICATIONS

Flow measurement in semiconductor production equipment

STANDARD SPECIFICATIONS

Measuring fluid	Gases Liquid (Equivalent to water: Density 1.0 g/cm ³ , Viscosity 1.0 mPa·s)	
Measuring range	Air	P-821 Min. 0.5 to 5 mL/min (nor) Max. 12 to 60 L/min (nor)
		P-823 Min. 5 to 50 mL/min (nor) Max. 6 to 60 L/min (nor)
	Water	P-821 Min. 5 to 50 mL/min Max. 0.4 to 2 L/min
		P-823 Min. 5 to 50 mL/min Max. 0.2 to 2 L/min
* When selecting a flow range, refer to "Index & Quick Reference for P Series Purgometers" (TG-S0001).		
Range ability	10 : 1 (10:2 for some models)	
Indication accuracy	P-821 : ±5% F.S. P-823 : ±3% F.S.	
Fluid pressure	Max. 0.8 MPa	
Fluid temperature	Max. 120°C (Depends on the gasket material)	
Material	Wetted part	SCS14 (Standard), SUS316 (Electrolytically polished)
	Tapered tube	Heat-resistant glass
	Gasket	Fluoro rubber (Max. 120°C) Chloroprene rubber (Max. 80°C) * The maximum fluid temperature for each gasket material may vary depending on usage and ambient conditions.
	Mounting plate	SPCC or C2801P
Cover	Acrylic	
Process Connection	Rc : 1/4" (Standard), 1/8" NPT : 1/4", 1/8" SW : 1/4", 3/8" VCR : 1/4", 3/8"	
Mounting	Lock nut mount on the panel front (Standard) Bezel mounting	
Mass	approx. 0.6 kg (P-821)	

ALARM CONTACT AND OUTPUT

Type	Availability	
	P-821	P-823
Reed switch type alarm unit	General	○
	UL-approved	○
PAU optical alarm unit	○	○

For CE approval, refer to Index & Quick Reference for P Series Purgometers (TG-S0001).

P-821/STANDARD FLOW RATE TABLE

When the fluid pressure is other than 0 MPa, refer to Index & Quick Reference for P Series Purgometers (TG-S0001).

For alarm output codes of 0 or E		For alarm output codes of A to D			
Air (0°C, 0 MPa)	Water	Air (0°C, 0 MPa)	Water	Alarm setting range	Alarm setting range
0.5 to 5 mL/min (nor)					
1 to 10 mL/min (nor)					
2 to 20 mL/min (nor)					
3 to 30 mL/min (nor)					
5 to 50 mL/min (nor)					
10 to 100 mL/min (nor)					
20 to 200 mL/min (nor) *5					
30 to 300 mL/min (nor)					
50 to 500 mL/min (nor)					
0.1 to 1 L/min (nor)					
0.2 to 2 L/min (nor)	5 to 50 mL/min				
0.3 to 3 L/min (nor)	10 to 100 mL/min				
0.5 to 5 L/min (nor)	20 to 200 mL/min				
1 to 10 L/min (nor)	30 to 300 mL/min				
2 to 20 L/min (nor)	50 to 500 mL/min	1 to 10 L/min (nor) *3	2 to 8 L/min (nor)		
3 to 30 L/min (nor) *1	0.1 to 1 L/min *2	3 to 15 L/min (nor)	3 to 12 L/min (nor)	50 to 500 mL/min	100 to 400 mL/min
10 to 50 L/min (nor)	0.3 to 1.5 L/min	6 to 30 L/min (nor)	6 to 24 L/min (nor)	0.1 to 1 L/min *4	0.2 to 0.8 L/min
12 to 60 L/min (nor)	0.4 to 2 L/min	10 to 50 L/min (nor)	10 to 40 L/min (nor)	0.3 to 1.5 L/min	0.3 to 1.2 L/min

Although other flow rate specifications are available, some flow ranges need to be changed. Contact us for details.

- * 1 10:2 when the range is more than 30 L/min (nor).
- * 2 10:2 when the range is more than 1 L/min.
- * 3 10:2 when the range is more than 10 L/min (nor).
- * 4 10:2 when the range is more than 1 L/min.
- * 5 For models with a flow rate range of less than 160 mL/min (nor), the alarm output code of E cannot be specified.



P-823/STANDARD FLOW RATE TABLE

When the fluid pressure is other than 0 MPa, refer to Index & Quick Reference for P Series Purgometers (TG-S0001).

For alarm output codes of 0 or E		For alarm output codes of A to D			
Air (0°C, 0 MPa)	Water	Air (0°C, 0 MPa)	Water	Alarm setting range	Alarm setting range
5 to 50 mL/min (nor)					
10 to 100 mL/min (nor)					
20 to 200 mL/min (nor)					
30 to 300 mL/min (nor)					
50 to 500 mL/min (nor)					
0.1 to 1 L/min (nor)					
0.2 to 2 L/min (nor)	5 to 50 mL/min				
0.3 to 3 L/min (nor)	10 to 100 mL/min				
0.5 to 5 L/min (nor)	20 to 200 mL/min				
1 to 10 L/min (nor)	30 to 300 mL/min				
2 to 20 L/min (nor)	50 to 500 mL/min	1 to 10 L/min (nor)	2 to 8 L/min (nor)		
3 to 30 L/min (nor)	0.1 to 1 L/min	2 to 20 L/min (nor)	4 to 16 L/min (nor)	50 to 500 mL/min	100 to 400 mL/min
5 to 50 L/min (nor)	0.15 to 1.5 L/min	3 to 30 L/min (nor)	6 to 24 L/min (nor)	0.1 to 1 L/min	0.2 to 0.8 L/min
6 to 60 L/min (nor)	0.2 to 2 L/min	5 to 50 L/min (nor)	10 to 40 L/min (nor)	0.15 to 1.5 L/min	0.3 to 1.2 L/min

Although other flow rate specifications are available, some flow ranges need to be changed. Contact us for details.

BASIC MODEL CODE

Model Code	Descriptions	Notes
P-82		
1	115mm	Different standard flow rate tables are provided for each code
3	224mm	
9	Special	
0	Not provided	Refer to "Index & Quick Reference for P Series Purgometers" (TG-S0001).
1	Bellows valve at the outlet	
2	Bellows valve at the inlet	
3	Needle valve at the outlet	
4	Needle valve at the inlet	
Z	Special	
0	Not provided	Refer to "Index & Quick Reference for P Series Purgometers" (TG-S0001).
A	Reed switch alarm (LO)	
B	Reed switch alarm (LC)	
C	Reed switch alarm (HO)	
D	Reed switch alarm (HC)	
E	PAU alarm unit provided	
Z	Special	
6	SCS14 (Standard)	
E	SUS316 (Electrolytically polished)	
Z	Special	
F	Fluoro rubber (Standard)	Select this code for ammonia gas.
C	Chloroprene rubber (CR)	
Z	Special	
R	Rc (Standard)	Bezel mounting is available. For details, refer to "Index & Quick Reference for P Series Purgometers" (TG-S0001).
N	NPT female	
S	SW	
V	VCR	
Z	Special	
1	1/8"	Selectable when the connection type code is R or N
2	1/4" (Standard)	
3	3/8"	
Z	Special	Selectable when the connection type code is S or V

OTHER AVAILABLE OPTIONS

You can specify the following options:
Two-point alarm, length of reed switch lead wire, double graduations, special graduations, built-in rubber fitting type, various fitting types, etc.
For details, refer to Index & Quick Reference for P Series Purgometers (TG-S0001).

ORDERING INFORMATION

Basic model code	Items to be specified
P-82 □ - □□ - □□ - □□	① Fluid name - ② Flow range - ③ Press. - ④ Temp. - ⑤ Mounting option - ⑥ Other options
(Select in the model code table.)	(Refer to Index & Quick Reference for P Series Purgemeters (TG-S0001).)

DIMENSIONS

● Standard type

P-82 □ - 40 - 6F - R2

- Lock nut mounting on the panel front
- Valve at the inlet (needle valve)

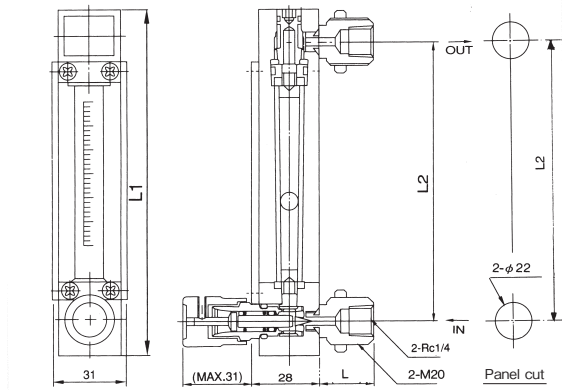

● Standard type

P-82 □ - 30 - 6F - S2

- Lock nut mounting on the panel front
- Valve at the outlet (needle valve)

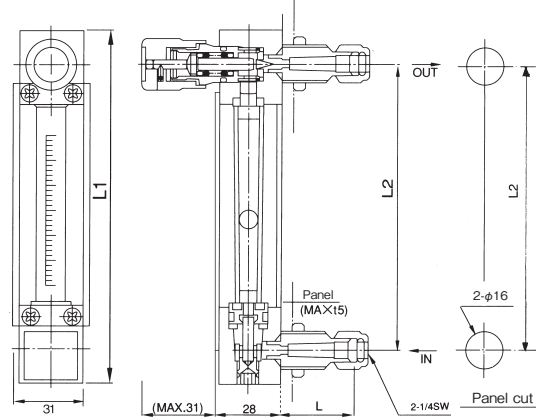

● Bezel mounting type

P-82 □ - 30 - □□ - □□

- Bezel mounting (Mounting option code: D)
- Valve at the outlet (needle valve)

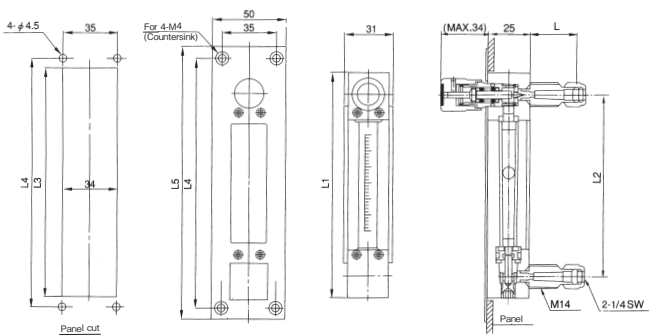

Dimension table

Model	Dimension (mm)				
	L1	L2	L3	L4	L5
P-821	143	115	145	160	175
P-823	252	224	254	265	280

● Standard material

Parts name	Standard material	Available material
Body	○ SCS14	SUS316
Tapered tube	○ Heat-resistant glass	—
Float * 1	○ SUS316, Glass, Ruby, Carbon	—
Packing	○ Fluoro rubber	Chloroprene rubber (CR)
Spindle	○ SUS316	—
Fitting	○ SUS316	—
Valve	○ SUS316	—
Mounting plate * 2	SPCC, C2801P	—
Cover	Acryl	—

Parts marked "○" come in contact with the measuring fluid.

* 1 We will select a proper material for your application.

* 2 C2801P is used when the alarm output code is one of A to D.

· SUS316 may be used instead of SUS304 due to production reasons.

· ASTM or AISI materials equivalent to JIS materials may be used due to production reasons.

Panel cut size

Connection size	Diameter (d) (mm)	Rear length L (mm)
Rc1/8, 1/8NPT	16	(22)
Rc1/4, 1/4NPT	22	(22)
1/4SW	16	(29.5)
3/8SW	22	(31.5)
1/4VCR	22	(30)
3/8VCR	32	(35.5)

Note: Use non-magnetic material for the panel when the alarm output code is one of A to D.

* Specification is subject to change without notice.

TOKYO KEISO CO., LTD.

Head Office : Shiba Toho Building, 1-7-24 Shibakoen, Minato-ku, Tokyo 105-8558

Tel : +81-3-3431-1625 (KEY) ; Fax : +81-3-3433-4922

e-mail : overseas.sales@tokyokeiso.co.jp ; URL : http://www.tokyokeiso.co.jp