

### OUTLINE

F-740 is a flow switch with compact design which will be installed onto horizontal pipe line through flanges. The detection part consists of a tapered detection tube and a float which moves vertically according to flow rate of fluid to be measured. The magnet moulded at the top of float rod actuates detection magnet to drive micro switch at the set point.

F-740 is suitable for the monitoring of flow for safety operation of various plants.



### STANDARD SPECIFICATION

- Available size : 15 ~ 150
- Measuring fluid : All kinds of liquids without solid particles  
(Viscosity : 5mPa · s or less)
- Fluid pressure : Max. 1.4 MPa
- Fluid temp. : -10 ~ +80°C
- Process Conn. : JIS10KRF, JIS10KFF, ANSI class 150 or other flanges
- Installation : Horizontal
- Alarm point : One point Low or One point High
- Setting accuracy : ±5% of set flow rate
- Reset span : Less than 30% of set flow rate
- Contact : Micro switch SPDT
- Capacity : 125 V / 250 V AC, 5 A (Resistance load)
- Enclosure : Waterproof (F-74□-□□□-□□),  
Flameproof d2G4 (EP-F-74□-□□□-□□)  
or Intrinsically safe (IS-F-74 □-□□□-□□,  
With a separate safety relay)
- Insulation resistance : 100 MΩ or more (between live terminals and ground)
- Di-electrical strength : 1000 V AC, for 1 min between non-connected terminals  
1500 V AC, for 1 min between live terminals and ground
- Amb. temp. : -25 ~ +80°C (Waterproof version)  
-10 ~ +60°C (EP and IS version)
- Cable entry : G1/2 (PF1/2) female thread  
(1/2 NPT adapter available on request)  
TIIS cable gland with flameproof gasket is available on request [cable diameter: 7 mm to 12 mm (standard: 10 mm to 11 mm)]
- Painting : Munsell 7.5 BG4/1.5 (Paint only the housing)
- Accessories : Safety relay unit  
(Option for IS-F-74□-□□□-□□)

### MODEL CODE

MODEL CODE							DESCRIPTION
	F	-	74	-	-	-	
		-		-	-	-	Waterproof enclosure
EP	-	-		-	-	-	Flameproof enclosure
IS	-	-		-	-	-	Intrinsically safe enclosure
FLOW DIRECTION				6	-	-	Left → Right
				7	-	-	Right → Left
CONNECTION SIZE				-	015	-	15mm
				-	020	-	20mm
				-	025	-	25mm
				-	040	-	40mm
				-	050	-	50mm
				-	065	-	65mm
				-	080	-	80mm
				-	100	-	100mm
CONNECTION RATING					-	R	JIS10KRF
					-	F	JIS10KFF
					-	A	ANSI class150 (Equiv.)
					-	Z	Others
MATERIAL						2	Class 2
						3	Class 3

**DIMENSIONS**

F-740 (Waterproof) and IS-F-740 (Intrinsically safe enclosure)

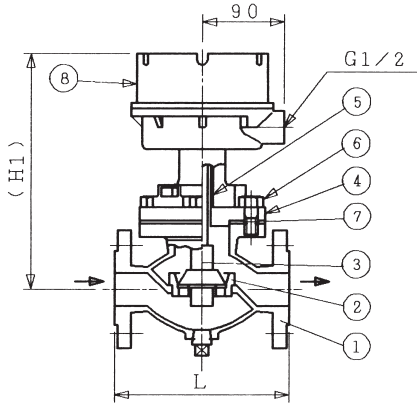

EP-F-740 (Flameproof enclosure)

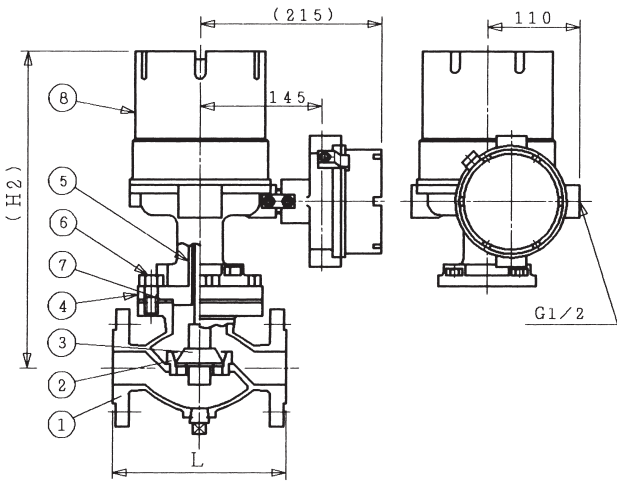

Meter size	L (mm)	(H1) (mm)	(H2) (mm)	Alarm setting flow rate (m³/h)*		Mass (Approx. kg)	
				For Low alarm	For High alarm	F-740	EP-F-740
15	160	230	370	0.1 ~ 2.0	0.13 ~ 2.0	10	14
20	160	230	370	0.1 ~ 2.0	0.13 ~ 2.0	10	14
25	160	230	370	0.1 ~ 2.0	0.13 ~ 2.0	11	15
40	190	250	380	0.2 ~ 4.3	0.26 ~ 4.3	15	19
50	200	280	410	0.5 ~ 10	0.65 ~ 10	20	24
65	220	290	420	0.8 ~ 13	1.0 ~ 13	26	30
80	250	310	440	1.0 ~ 25	1.3 ~ 25	32	36
100	290	310	440	1.8 ~ 40	2.3 ~ 40	50	54

\* : Pre-set at factory. (Fixed)

**STANDARD MATERIAL**

No.	Parts Name	Class 2	Class 3
1	Body	SCS14	SCS14
2	Detecting Tube	SUS304	SUS316
3	Float Ass'y	SUS304	SUS316
4	Upper Flange	SUS304	SUS316
5	Lead Pipe	SUS304	SUS316
6	Bolt	SS400	SS400
7	Gasket	Non-asbestos or PTFE	Non-asbestos or PTFE
8	Housing	Aluminum	Aluminum

**WIRING**

M3 screw terminal (F-740 and IS-F-740)

M4 screw terminal (EP-F-740)

Figure shows the condition when switch is not actuated.

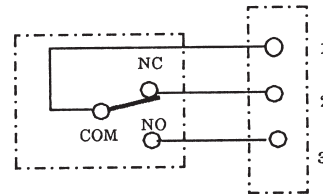

**ORDERING FORM**

Specify the following for order / inquiry ;

MODEL	<input type="checkbox"/> -F-74 <input type="checkbox"/> - <input type="checkbox"/> <input type="checkbox"/> <input type="checkbox"/> - <input type="checkbox"/> <input type="checkbox"/>
QUANTITY	
FLUID NAME	
DENSITY	
VISCOSITY	mPa · s
PRESSURE	MPa
TEMPERATURE	°C
GASKET MATERIAL	<input type="checkbox"/> Non-asbestos <input type="checkbox"/> PTFE
ALARM POINT	<input type="checkbox"/> LOW <input type="checkbox"/> HIGH m³/h
CABLE ENTRY	<input type="checkbox"/> G 1/2 <input type="checkbox"/> 1/2 NPT
SPECIAL INSTRUCTION, IF ANY	

\* Specification is subject to change without notice.

**TOKYO KEISO CO., LTD.**

Head Office : Shiba Toho Building, 1-7-24 Shibakoen, Minato-ku, Tokyo 105-8558

Tel : +81-3-3431-1625 (KEY) ; Fax : +81-3-3433-4922

e-mail : overseas.sales@tokyokeiso.co.jp ; URL : https://www.tokyokeiso.co.jp