



TECHNICAL GUIDANCE

VF-2300

Vortex Flow Sensor

OUTLINE

The VF-2300 Flow Sensor is an improved version of well-received VF-2000 and expands the flow range to 250L/min. The VF-2300 Flow Sensor offers a cost-effective instrument for the measurement of liquid flow.

A simple and compact design makes the VF-2300 a good choice for the measurement of water, pure water, cooling water.

Current output model, Pulse output model and Display model with current / alarm outputs are available. Fitting is selectable from various types according to use.

FEATURES

- ❑ Simple and Compact Design
The VF-2300 Flow Sensor is assembled with a few pieces of components. The sensor body and Shedder bar (vortex generator) are molded as one component. This design approach has reduced the cost as well as the size and weight of the flowmeter. Sensor body is made of PPS (Polyphenylene sulfide) and is designed to eliminate deposits.
- ❑ No Maintenance Cost
Since the VF-2300 has no moving parts, no maintenance is needed.
- ❑ Low Pressure Loss
A combination of straight flow path and Shedder bar gives a lower pressure loss. (27kPa at 200L/min)
- ❑ Various fittings are lined-up
In addition to Taper Pipe Threads (R), TS socket, Flange (JIS 10K), Taper Pipe Threads (Rc) are available.
- ❑ Display Model with Current and Alarm Output
3-digit LED display for flow rate, current output and alarm outputs (2-point) are provided in compact design.
- ❑ CE Marking
The VF-2300 meets the EC directive for CE mark.

OPERATING PRINCIPLE

A bluff body or Shedder bar in the flow generates a street of vortices downstream. The VF-2300 Flow Sensor measures the flow rate by counting the number of vortices with a piezoelectric sensor.

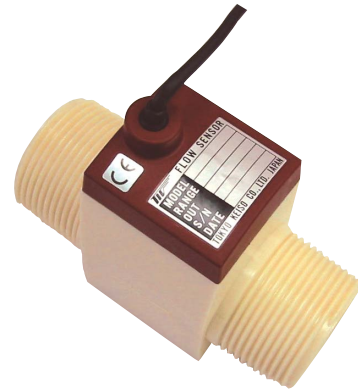

SPECIFICATIONS

Specifications		Model		
		Current Output Model	Pulse Output Model	Display/Current output Model
		VF-2316	VF-2326	VF-2336
Measurable Fluid		Pure water, Water, Low viscosity chemical liquid		
Flow Range *1		25 to 250 L/min		
Accuracy (Additional Error for LED display)*1		±3%F.S.		±3%F.S. (1 digit)
Repeatability		±0.5%F.S		
Fluid Pressure		Body : 1MPa Max.*2		
Fluid Temperature		Body : 0 to 90°C *2		
Ambient Temperature		0 to 50°C		0 to 50°C [Refer to Figure 1]
Ambient Humidity		5 to 90%RH		
Operating Voltage		10.8 to 26.4V DC		
Rated Power		1W	0.5W	2W
Display	Flow	-		3-digit LED
	Alarm	-		2 LED
Display Resolution		-		1L/min
Output		Current output 4 to 20mA DC (3-wire) Load : 0 to 250 ohms at 12V DC 250 to 600 ohms at 24V DC [Refer to Figure 3] Damping Time Constant 1sec (63% Response)	Unscaled pulse output Open collector Max. 10mA/30V DC Pulse duty factor ; approx 50% Output frequency at 100% flow*1 750Hz	Current output 4 to 20mA DC (3-wire) Load : 0 to 250 ohms at 12V DC 250 to 600 ohms at 24V DC [Refer to Figure 2] Damping Time Constant 1sec (63% Response) Alarm output (2-point) Open collector, Max. 80mA/30V DC Hysteresis ; equal to display resolution
Cable		0.2mm ² X 3C (AWG24), 3m, Outside diameter 3.5mm (Soldered end finish)		0.2mm ² X5C (AWG24), 3m, Outside diameter 4.5mm (Soldered end finish)
Mass	Body	145g		175g
	Cable	75g		90g
Enclosure Classification		IP64		
Min. Straight Pipe Run		Upstream 10D, Downstream 5D (D: Normal Pipe Size)		
Process Connection		Taper pipe Thread (R1 1/4), TS socket Fitting (Nominal diameter 30mm) attached, 32A JIS10K FF Flange fittings attached or Taper Pipe Threads fitting (Rc1 1/4) attached		
Body Materials	Body	PPS (Polyphenylene sulfide)		
	Sensor	Piezoelectric element molded with PPS		
	O-ring	Fluorine rubber (FKM) or Etylene propylene rubber (EPDM)		
	Cover	Poly-butylene trephthalate (PBT)		
	Cable sheath	Heat-resistant PVC		
Fitting Materials	Fitting	PVC		
	O-ring	Fluorine rubber (FKM) or Etylene propylene rubber (EPDM)		

*1 Conditions for caribration

Fluid : Water, Fluid temperature : 20°C, Ambient temperature : 23°C, Supply voltage : 24V DC

*2 Specifications of pressure and temperature may change depending on specification of fitting.

Fluid and Ambient Temperature (Only for Display type VF-2336)

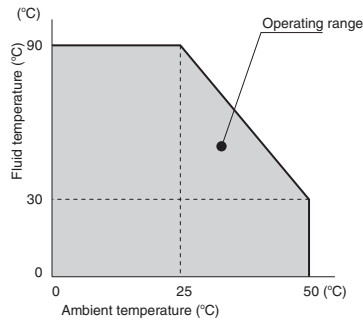

Figure 1

Load Resistance Range (VF-2316, VF-2336)

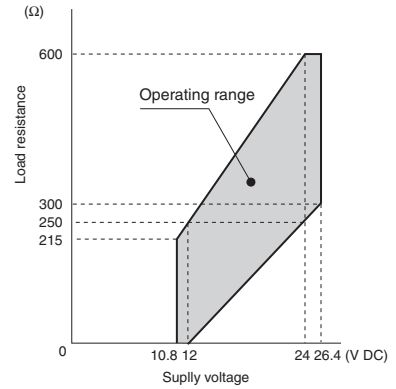

Figure 2

Fluid Pressure and Temperature

Fitting material : PVC

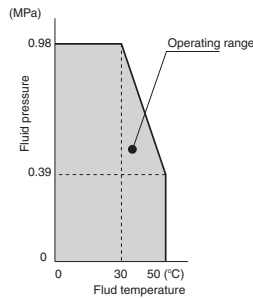
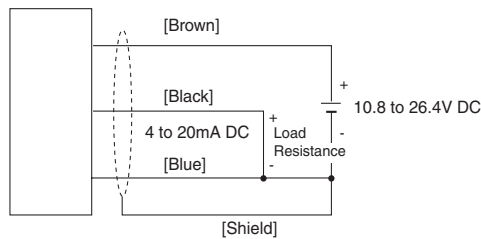

Figure 3

WIRING DIAGRAM

● Current Output Model (VF-2316)



● Pulse Output Model (VF-2326)

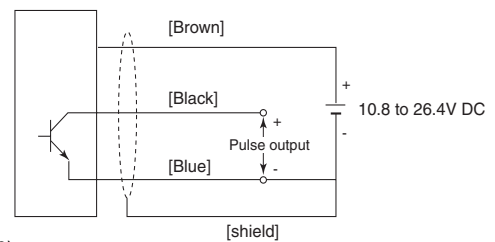

● Display / Current Output Model (VF-2336)

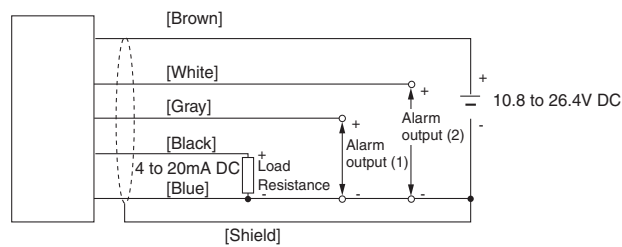

MODEL CODE

Model code							Description
VF - 23	<input type="checkbox"/>	<input type="checkbox"/>	- <input type="checkbox"/>	<input type="checkbox"/>	<input type="checkbox"/>	/ <input type="checkbox"/>	
Type/Output	1						Current output : 4 to 20mA DC(3-wire)
	2						Pulse output : Open collector (Unscaled)
	3						Display : Flow rate (3-digit LED), Alarm (2 LED) Current output : 4 to 20mA DC (3-wire) Alarm output : Open collector (2 points)
Flow Range	6						25 to 250 L/min
O-ring Material			- F				Fluorine rubber (FKM)
			- E				Ethylene propylene rubber (EPDM)
Process Connection				0			R1 1/4 Taper Pipe
				1			PVC / 30mm TS Socket fittings attached
				2			PVC / 32A JIS 10K FF Flange fitting attached
				3			PVC / Rc1 1/4 Taper Pipe Threads
				9			Others
Flow Unit				1			L/min
Option						/ <input type="checkbox"/>	Option Code

OUTLINE DIMENSIONS

● Current output / Pulse output Model

● Display / Current output type

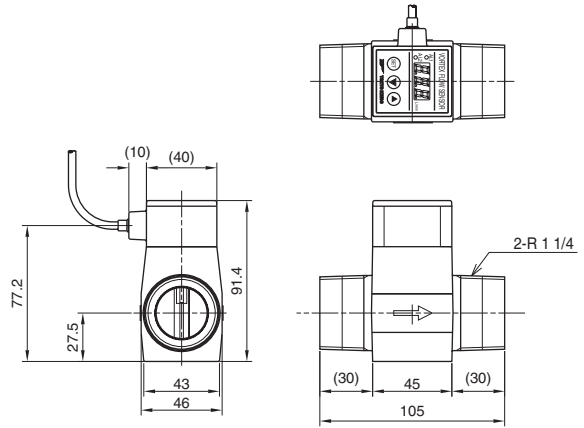
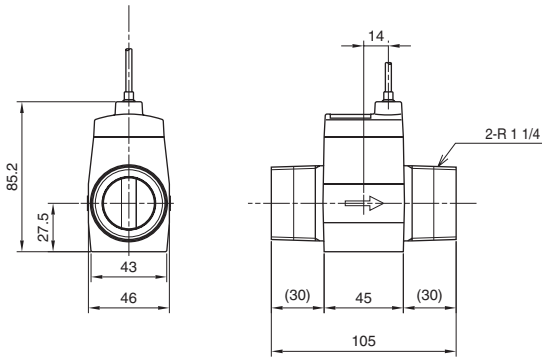

● With 30mm TS socket fittings

● With Taper pipe thrad (Rc1/4) fittings

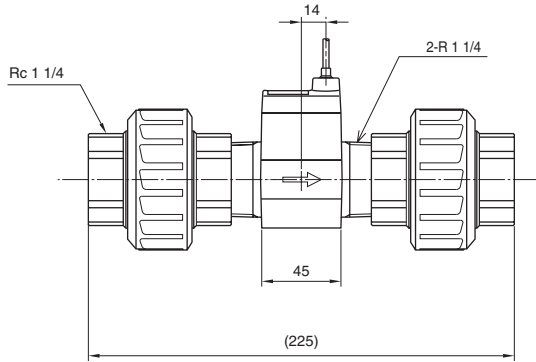
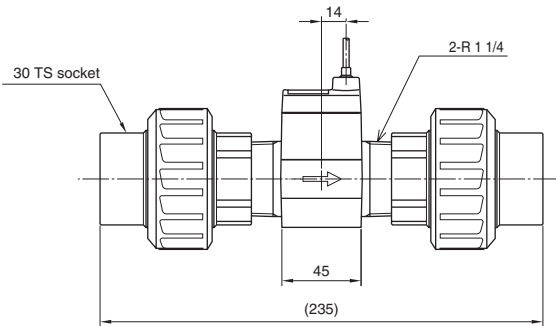

● With 32A JIS10K FF Flange fittings

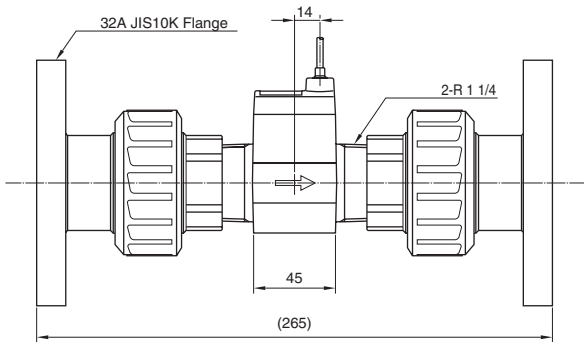

ORDERING INSTRUCTIONS

Specify the following when ordering:

1. Model code
2. Fluid name

* Specification is subject to change without notice.

TOKYO KEISO CO., LTD.

Head Office : Shiba Toho Building, 1-7-24 Shibakoen, Minato-ku, Tokyo 105-8558
 Tel : +81-3-3431-1625 (KEY) ; Fax : +81-3-3433-4922
 e-mail : overseas.sales@tokyokeiso.co.jp ; URL : http://www.tokyokeiso.co.jp

