



# TECHNICAL GUIDANCE

COST EFFECTIVE FLOW MEASUREMENT FOR  
LIQUIDS AND GASES

## O-180/780 Series

ORIFLOMETER

### GENERAL

O Series ORIFLO METER is a By-pass Orifice type flowmeter. Small sized variable flowmeter is installed onto measuring tube part in which an orifice plate for by-pass flow is integrated.

Three different process connections, i.e., "SCREW", "FLANGE" and "WAFER", are available for Selection.

An isolation valve is available between measuring tube and indicator for indicator maintenance work even during process operation. This eliminates the necessity of by-pass piping for maintenance purpose and saves total piping cost.

Stainless steel and PVC versions were added to the lineup of materials to cover a wider range of fluid types.

Alarm contacts are available as option. (O-780 Series)

See quick delivery model details on page 7.



### FEATURES

#### ❑ LOW COST / HIGH PERFORMANCE

Thanks to unique orifice by-pass system, total instrumentation cost can be saved especially for medium and large sized piping measurement.

#### ❑ COMPACT DESIGN

Small sized indicator saves space in plants.

#### ❑ EASY INSTALLATION

"SCREW", "FLANGE" and "WAFER" are ready to meet field requirements.

By-pass piping for maintenance purpose can be skipped by using isolation valve.

#### ❑ FOR ALL FLOW DIRECTIONS

BOTTOM TO TOP, TOP TO BOTTOM, LEFT TO RIGHT, RIGHT TO LEFT.

ORIFLO is applicable for all possible flow directions. Change of such flow direction is possible in field even after installation.

#### ❑ ALARM CONTACT

Besides local flow rate indication, alarm contact (s) are available. ORIFLO can be used as FLOWSWITCH.

#### ❑ EASY MAINTENANCE

Simple design and limited number of parts saves maintenance work.

#### ❑ HIGH ANTI CORROSIVE CAPABILITY VERSION

Stainless steel and PVC versions are available for corrosive fluid application.

### MAIN APPLICATIONS

- ❑ Hot and cool water as well as air flow measurement at Air conditioning
- ❑ Medium and large line measurement at General process
- ❑ Cooling water lines
- ❑ Water treatment process
- ❑ Pure and Ultra pure water production facilities process
- ❑ Testing of Fire fighting pumps
- ❑ Testing of blowers
- ❑ Others

**OPERATION PRINCIPLE**

As shown in the figure, differential pressure is produced across the Main orifice plate by flow velocity which corresponds to flow rate.

A small sized flowmeter (Variable area flowmeter) is mounted onto this differential pressure production unit. By this arrangement, the flow rate through the flowmeter corresponds to the flow rate through the Process piping.

Thus, scale range for Process piping can be engraved onto the small sized flowmeter and the flow rate through the Process piping is indicated by the position of float of the flowmeter.

Normally, an isolation valve is provided between the measuring tube and the indicator for the purpose of indicator maintenance with no interference of process operation. (This valve is for maintenance/ isolation purpose and not for flow control purpose.)

A magnet piece is buried into the float for Alarm version which attracts reed switch for alarm contact output. The setting point of alarm is adjustable by shifting the location of reed switch.

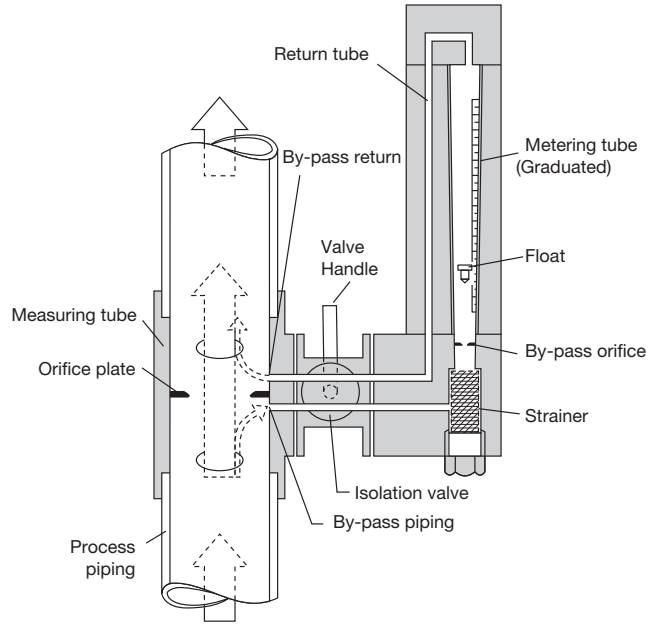

**CONSTRUCTION**

- ORIFLO consists of :

  - a. Indicator
  - b. Isolation valve
  - c. Measuring tube

The figure is an extended view of metallic material version.  
(It would differ in case of PVC version.)

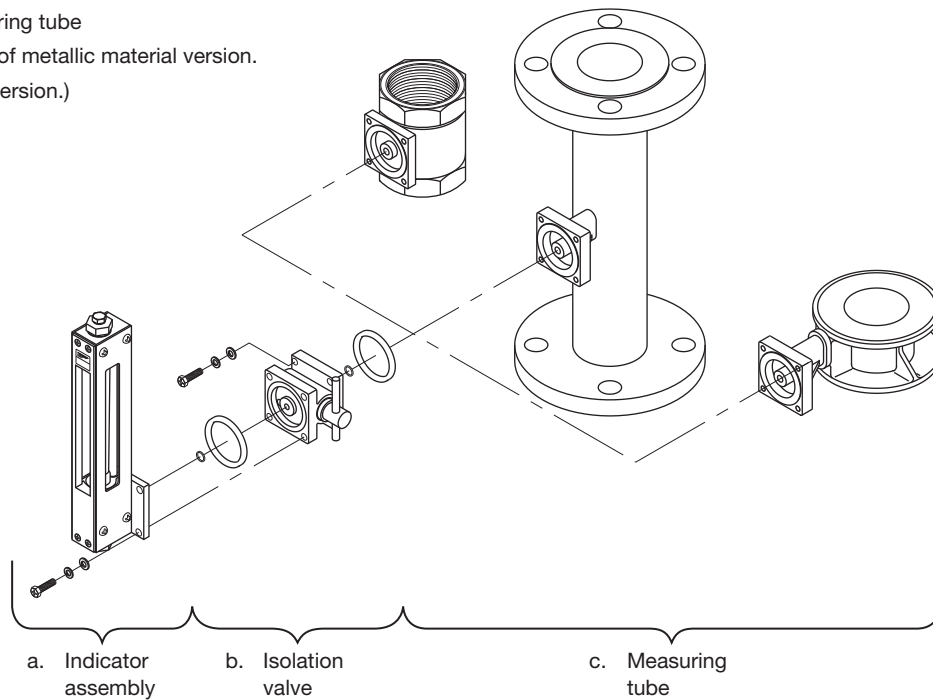

## MATERIAL CONSTRUCTION

Different materials are available for measuring tube, isolation valve, indicator and sealings to cover various fluids as per the following table ;

Part name		Material Class 2	Material Class 3	Material Class 4	Material Class 5
Measuring tube	Screw connection	SCS14	SCS14	PVC	HT-PVC
	Flange connection	SUS304	SUS316	PVC	HT-PVC
	Wafer connection	SUS304	SUS316	PVC	HT-PVC
SCS14*1		SCS14*1			
Orifice plate		SUS304	SUS316	PVC	HT-PVC
Isolation valve body / shaft		SCS14/SUS316	SCS14/SUS316	HT-PVC/PP	HT-PVC/PP
Indicator body		SCS14	SCS14	HT-PVC	HT-PVC
Metering tube		Heat-resistant glass	Heat-resistant glass	Heat-resistant glass <sup>*2</sup>	Heat-resistant glass
Float	For liquids	SUS316	SUS316	PVC	HT-PVC
	For gases	Glass	Glass	Glass	Glass
Cover, scale		SUS304/ABS Polycarbonate	SUS304/ABS Polycarbonate	Polycarbonate	Polycarbonate
Packing		NBR	NBR	-	-
		FPM	FPM	FPM	FPM
		EPDM	EPDM	EPDM	EPDM

\*1 SCS14 for 10 mm to 250 mm (JIS 10K).

\*2 PVC tapered tubes

(Float: PTFE, maximum pressure of 0.6MPa, maximum temperature of 40°C) are also available as a special order for measuring liquids with the local indicator type.

Abbreviation of material

PP	: Polypropylene
NBR	: Nitrile Butadiene Rubber
FPM	: Fluoro rubber
EPDM	: Ethylene-propylene rubber
HT-PVC	: High temp. PVC
ABS	: Acrylonitrile Butadiene Styrene

## MODEL CODE

MODEL CODE										DESCRIPTION	
O	-										LOCAL INDICATION ONLY
FUNCTION	1	8									LOCAL INDICATION + ALARM CONTACT
	7	8									LOCAL INDICATION + OPTICAL ALARM UNIT (OLD MODEL O-76□)
	6	8									LOCAL INDICATION + OPTICAL ALARM UNIT (OLD MODEL O-76□)
FLOW DIRECTION	1										BOTTOM→TOP
	6										LEFT→RIGHT
	7										RIGHT→LEFT
	8										TOP→BOTTOM
PROCESS CONNECTION	-	S									SCREW CONNECTION
	-	F									FLANGE CONNECTION
	-	W									WAFER CONNECTION
ISOLATION VALVE *1			N								NOT PROVIDED
			C								PROVIDED
			B								INDICATOR SEPARATION VERSION
MAIN PIPE SIZE	-	0	1	0							10mm
	-	0	1	5							15mm
	-	0	2	0							20mm
	-	0	2	5							25mm
	-	0	3	2							32mm
	-		∅								∅
	-	4	5	0							450mm
	-	5	0	0							500mm
MATERIAL CODE					-	2					MATERIAL CLASS 2 (SUS304)
					-	3					MATERIAL CLASS 3 (SUS316)
					-	4					MATERIAL CLASS 4 (PVC)
					-	5					MATERIAL CLASS 5 (HT-PVC)
PACKING MATERIAL *2								N			NBR
								F			FPM
								E			EPDM
								Z			SPECIAL
TERMINAL BOX *3								-	T		Yes
								-	N		No

\*1 Ball valves are provided for indicator separation version (O-□8□-□B).

Refer to page 11 for details.

\*2 NBR packings are not available for meters with material codes 4 and 5.

\*3 Select when using O-780 series.

**STANDARD SPECIFICATION**

● Measuring fluid :

Liquids (upto 3 mPa·s viscosity)  
Gases

(Not suitable for opaque liquids, slurries and steam)

● Main pipe sizes :

Std. 10mm to 300mm  
Option 350mm to 500mm  
Special Larger than above on request  
(For details, contact us.)  
For meters of the wafer connection and flange connection types with the main pipe size 350 mm and 400 mm or higher, respectively, pressure tests are conducted only on indicators and isolation valves, not on measuring tubes, which are tested with the PT method instead.

● Process connection :

Screw connection: Rc and NPT  
Size availability:  
10 mm to 100 mm  
(10 mm to 50 mm for PVC, 10 mm to 40 mm for HT-PVC versions)  
Flange connection: JIS10KFF/RF, ANSI/JPI CLASS 150, and others  
Size availability: More than 10 mm  
Wafer connection: JIS10K, ANSI/JPI CLASS 150, and others  
Size availability: More than 10 mm

● Fluid temp

Material	Maximum fluid temp.
Metallic indicators (field indication type)	120°C
Metallic indicators (with alarm contacts)	80°C
PVC indicators	60°C
HT-PVC indicators	80°C
NBR packing / EPDM packing	80°C
FPM packing	120°C
Stainless steel valve shaft	120°C

It is general data, and the maximum temperature may change by terms of use and environment.

● Fluid press. : Max. 1.0MPa (Metallic versions, Material class 2,3)  
Max. 0.6MPa (PVC, HT-PVC versions, Material class 4,5)

● Range ability : Std. 10: 2  
Different range ability applicable for special design products.

● Indication accuracy : ±3% F.S.

● Standard Differential pressure :

Function	Indicator material	DP (kPa)		Range ability	
		For liquids	For gases	For liquids	For gases
Local indication	Metallic material (Glass tapered tube) 0-18□-□□-□□□ - $\frac{2}{3}$	15	5	10:2	10:2
	PVC, HT-PVC 0-18□-□□-□□□ - $\frac{4}{5}$	15	5	10:2	10:2
Local indication + Alarm	Metallic material (Glass tapered tube) 0-78□-□□-□□□ - $\frac{2}{3}$	20	20	10:2	10:2
	PVC, HT-PVC 0-78□-□□-□□□ - $\frac{4}{5}$	20	20	10:2	10:3

Other special Differential pressure design available on request. Consult factory for details.

Optical alarm type (O-68□) has the same diff. pressure as local indication type.

● Standard painting :Munsel 7.5G4/1.5 (only for O-780 Series terminal box)  
PVC part will not be painted.  
Stainless steel is not painted.

● Alarm function :1 or 2 point alarm can be additionally provided.

● Type of contact :Reed switch (SPST)(Self-preservation)

● Termination :M3.5 screw terminal

Terminal connection :

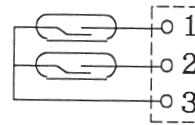

(SELF RETENTIONING TYPE)

1 point alarm : ①-③

2 point alarm : ①-③, ②-③

● Contact capacity :

10 VA AC

(Max. voltage 125 V AC, Max. current 0.5A)

10 W DC

(Max. voltage 100 V DC, Max. current 0.5A)

Use RD-1000 type Relay Driver if larger contact capacity is required.

(Separate TECHNICAL GUIDANCE available on request)

In case of lamp load, inductive load and electric motor load, the surge current may be induced. Provide the suitable protection such as CR, surge suppression, relays etc.

● Reset Span : Max. 20% F.S. (Against flow calibration)

● Special treatment : Water free and oil free treatment are available on request.

## MAX FLOW SIZE BY MAIN PIPE SIZE

### FOR LIQUID MEASUREMENT

MAIN PIPE SIZE	Flow rate Water m <sup>3</sup> /h (Density 1.0g/cm <sup>3</sup> , Viscosity: 1.0 mPa.s)					
	DP 10kPa *1		DP 15kPa *2		DP 50kPa *3	
10mm	0.25 to	0.5	0.25 to	0.6	0.3 to	1.1
15mm	0.3 to	1	0.3 to	1.3	0.35 to	2.3
20mm	0.4 to	2.3	0.4 to	2.9	0.45 to	5.2
25mm	0.5 to	4	0.5 to	4.9	0.65 to	8.9
32mm	0.6 to	6.7	0.6 to	8.2	1.1 to	14
40mm	0.7 to	9.1	0.8 to	11	1.4 to	20
50mm	1 to	14	1.2 to	17	2.2 to	32
65mm	1.6 to	23	2 to	29	3.5 to	53
80mm	2.1 to	33	2.6 to	41	4.6 to	75
100mm	3.5 to	57	4.3 to	70	7.8 to	120
125mm	5.4 to	88	6.6 to	100	12 to	190
150mm	7.6 to	120	9.3 to	150	17 to	270
200mm	13 to	210	16 to	260	29 to	470
250mm	20 to	330	25 to	400	44 to	740
300mm	29 to	470	35 to	580	64 to	1000
350mm	36 to	590	43 to	720	79 to	1300
400mm	47 to	780	57 to	950	110 to	1700
450mm	60 to	990	73 to	1200	140 to	2200
500mm	74 to	1200	90 to	1500	170 to	2700

\*1: Range ability 10 : 3

\*2: Range ability 10 : 2

\*3: Range ability 10 : 2 (10 : 1.5 on request)

Consult factory for other main pipe sizes and scale ranges, if required.

Above table is indicated based on water flow measurement (Density 1.0g/cm<sup>3</sup> Viscosity 1.0mPa.s). When the fluid Specific gravity is other than 1.0, conduct conversion calculation by the following formula, and refer to the table :

$$Q_w = Q \times \sqrt{\frac{\rho_o (\rho_f - 1)}{(\rho_f - \rho_o)}}$$

Example: The flow rate converted to water, of alcohol 50m<sup>3</sup>/h (Density: 0.8g/cm<sup>3</sup>) can be calculated as follows. The flowmeter to be used is to be stainless (local indication only).

$$Q_w = 50 \times \sqrt{\frac{0.8 \times (7.9 - 1)}{(7.9 - 0.8)}}$$

$$= 44.1 \text{ (m}^3\text{/h)}$$

From the above table, select the main pipe size (100mm, 125mm etc.) in which 44.1m<sup>3</sup>/h is included.

Q<sub>w</sub> : Water converted range  
 Q : Flow range for actual liquid  
 ρ<sub>o</sub> : Density of actual Liquid  
 ρ<sub>f</sub> : Density of float

Float material	Density of float
Stainless steel (Local indicator)	7.9 g/cm <sup>3</sup>
Stainless steel (With alarm)	7.3 g/cm <sup>3</sup>
PVC (Local indicator)	2.8 g/cm <sup>3</sup>
PVC (With alarm)	3.2 g/cm <sup>3</sup>

The calculation of figures in the above flow range table has been made on the premises that SGP, a JIS code name for a carbon steel pipe for ordinary piping, had been used for main pipes. In case of main pipes other than SGP, multiply the above liquid quantity by (the inner diameter of a main pipe used ÷ the inner diameter of a SGP pipe)<sup>2</sup>.

For the measuring pipe of Material Class 4 and Class 5, it means the inner diameter of VP (Rigid Polyvinyl Chloride pipes). Depending on the main pipe size, but multiply the above flow range by 0.75 to 1.

Inner diameter of a SGP pipe

MAIN PIPE SIZE	Inner diameter [mm]
10mm	12.7
15mm	16.1
20mm	21.6
25mm	27.6
32mm	35.7
40mm	41.6
50mm	52.9
65mm	67.9
80mm	80.7
100mm	105.3
125mm	130.8
150mm	155.2
200mm	204.7
250mm	254.2
300mm	304.7

## FOR GAS MEASUREMENT

ORIFLO for gas flow measurement will be calibrated and graduated according to customers' individual operating conditions such as density, pressure and temperature. Refer to ORDERING INFORMATION on Page 15 and specify the operating conditions. The following table shows the air flow range at 0°C and 1atm for each main pipe size. Conversion calculation is required in case the actual operating conditions differ from this.

MAIN PIPE SIZE	Flow rate AIR m <sup>3</sup> /h (nor) (0°C, 1 atm)								
	DP 5kPa *1		DP 10kPa *2		DP 20kPa *2				
10mm	3.5	to	10	3.5	to	13	3.5	to	18
15mm	4.5	to	20	4.5	to	28	4.5	to	38
20mm	5.5	to	45	5.5	to	63	7	to	85
25mm	6.5	to	77	8	to	100	11	to	140
32mm	9.5	to	120	13	to	170	17	to	240
40mm	12	to	170	17	to	240	22	to	320
50mm	19	to	280	26	to	380	35	to	520
65mm	31	to	460	42	to	630	58	to	860
80mm	40	to	650	56	to	900	76	to	1200
100mm	68	to	1100	91	to	1500	130	to	2000
125mm	110	to	1700	150	to	2300	200	to	3100
150mm	150	to	2300	210	to	3300	290	to	4400
200mm	250	to	4100	350	to	5600	480	to	7700
250mm	390	to	6400	540	to	8800	740	to	12000
300mm	560	to	9200	770	to	12000	1100	to	17000
350mm	690	to	11000	950	to	15000	1400	to	21000
400mm	900	to	15000	1300	to	20000	1800	to	28000
450mm	1200	to	19000	1700	to	26000	2300	to	36000
500mm	1500	to	23000	2100	to	33000	2800	to	44000

\*1: Range ability 10 : 2

\*2: Range ability 10 : 2 (10 : 1.5 on request)

Consult factory for other scale ranges, if required.

Gas measurement versions are all custom made. Figures in above table shows the flow rate based on air at 0°C, 1 atm. Conduct conversion calculation and refer to the table.

### Conversion calculation

$$Q_A = Q \times C_p \times C_t \times C_p$$

$Q_A$ : Converted Air flow

$Q$ : Flow rate of Actual Gas

$C_p$ :  $\sqrt{\rho/1.293}$  [ $\rho$ =density of gas in kg/m<sup>3</sup> (nor)]

$C_t$ :  $\sqrt{(273+t)/273}$  (t=operating temp., °C)

$C_p$ :  $\sqrt{0.1013/(0.1013+p)}$  (p=operating press. MPa)

Taking, nitrogen gas, density; 1.251kg/m<sup>3</sup> (nor), pressure; 0.6MPa, and temperature; 20°C for example, the flow rate of 300m<sup>3</sup>/h (nor) converted to air can be calculated as follows:-

$$Q_A = 300 \times \sqrt{\frac{1.251}{1.293}} \times \sqrt{\frac{273+20}{273}} \times \sqrt{\frac{0.1013}{0.1013+0.6}}$$

$$= 116.2\text{m}^3/\text{h (nor)}$$

From the above table, select the main pipe size (32mm, 40mm etc.) in which 116.2m<sup>3</sup>/h (nor) is included.

The calculation of figures in the above flow range table has been made on the premises that SGP, a JIS code name for a carbon steel pipe for ordinary piping, had been used for main pipes. In case of main pipes other than SGP, multiply the above liquid quantity by (the inner diameter of a main pipe used ÷ the inner diameter of a SGP pipe)<sup>2</sup>.

For the measuring pipe of Material Class 4 and Class 5, it means the inner diameter of VP (Rigid Polyvinyl Chloride pipes). Depending on the main pipe size, but multiply the above flow range by 0.75 to 1.

Inner diameter of a SGP pipe

MAIN PIPE SIZE	Inner diameter [mm]
10mm	12.7
15mm	16.1
20mm	21.6
25mm	27.6
32mm	35.7
40mm	41.6
50mm	52.9
65mm	67.9
80mm	80.7
100mm	105.3
125mm	130.8
150mm	155.2
200mm	204.7
250mm	254.2
300mm	304.7

●Scale graduation

Standard scale division is set as per following figure. Select a desirable scale graduation from the figures below.

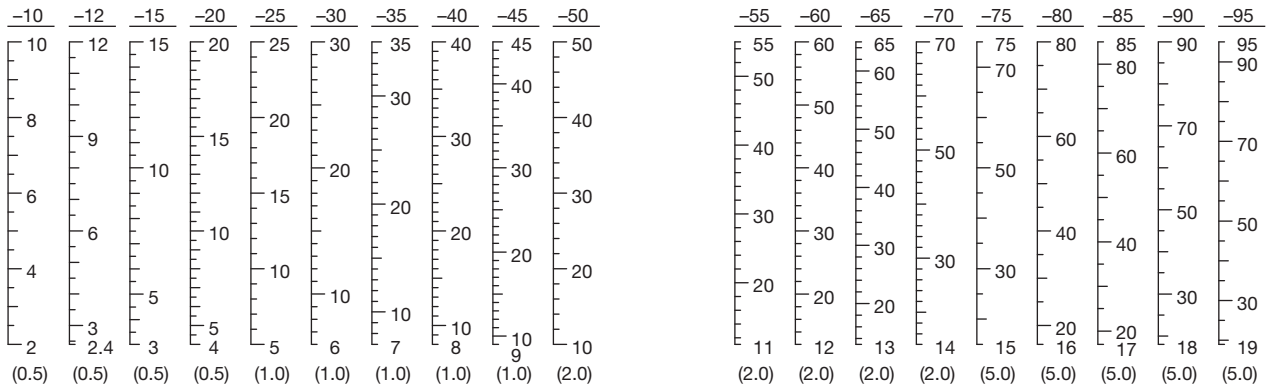

The figures in ( ) shows minimum graduation of scale. These figures may change according to the differential pressure.

Series for quick delivery O-180-□□-□□□□-2F

Appoint "model code" when ordering. Parts such as indicator, isolation valve and measuring tube shall be delivered disassembled. Put them together in accordance with the required flow direction.

●SPECIFICATION

- LIQUID : Water (Double scale of m<sup>3</sup>/h and L/min)
- DENSITY : 1.0 g/cm<sup>3</sup>
- VISCOSITY : 1.0 mPa·s
- MAX. PRESSURE : 15 kPa (Screw connection)  
20 kPa (Wafer connection)

MAIN PIPE SIZE	FLOW SCALE		MODEL CODE	
			SCREW CONNECTION (Rc)	WAFER CONNECTION (JIS-10K)
10A	0.1 to 0.5	m <sup>3</sup> /h	O-180-SC-010-2F	—
	(1.7 to 8.3)	L/min		
15A	0.2 to 1	m <sup>3</sup> /h	O-180-SC-015-2F	—
	(3.3 to 16.7)	L/min		
20A	0.5 to 2.5	m <sup>3</sup> /h	O-180-SC-020-2F	—
	(8.3 to 41.7)	L/min		
25A	1 to 5	m <sup>3</sup> /h	O-180-SC-025-2F	O-180-WC-025-2F
	(17 to 83)	L/min		
32A	1.6 to 8	m <sup>3</sup> /h	O-180-SC-032-2F	—
	(26.7 to 133)	L/min		
40A	2 to 10	m <sup>3</sup> /h	O-180-SC-040-2F	O-180-WC-040-2F
	(33 to 167)	L/min		
50A	3.6 to 18	m <sup>3</sup> /h	O-180-SC-050-2F	O-180-WC-050-2F
	60 to 300	L/min		
65A	6 to 30	m <sup>3</sup> /h	O-180-SC-065-2F	O-180-WC-065-2F
	100 to 500	L/min		
80A	8 to 40	m <sup>3</sup> /h	O-180-SC-080-2F	O-180-WC-080-2F
	(133 to 667)	L/min		
100A	14 to 70	m <sup>3</sup> /h	O-180-SC-100-2F	O-180-WC-100-2F
	(233 to 1167)	L/min		

●Packing method when delivered  
The 3 parts of indicator, isolation valve, and measuring tube are packed as per picture.

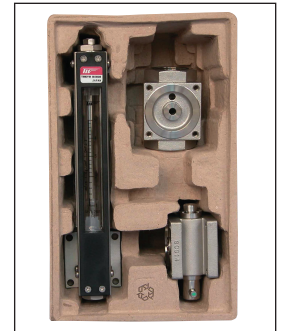

●Scale graduation

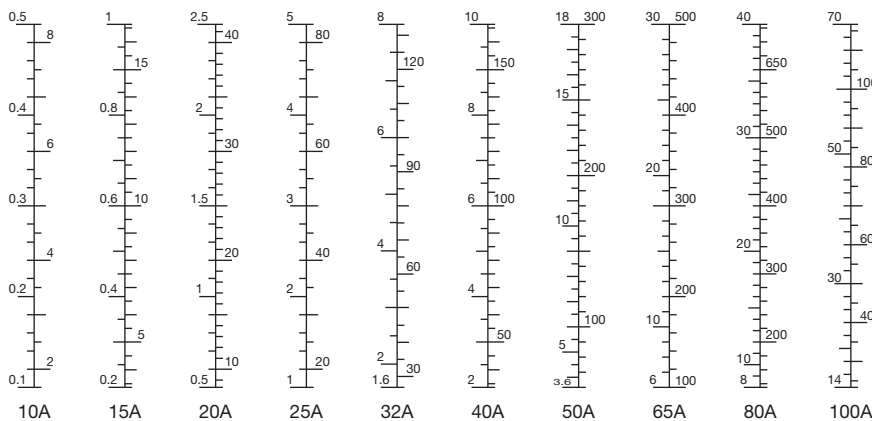

Note: The unit of L/min for 100A is ×10L/min.

EXTERNAL DIMENSION

● SCREW CONNECTION TYPE O-18 □-SC-□□□-□□

① MATERIAL CLASS 2, 3 (SCS14) 10 mm to 50 mm

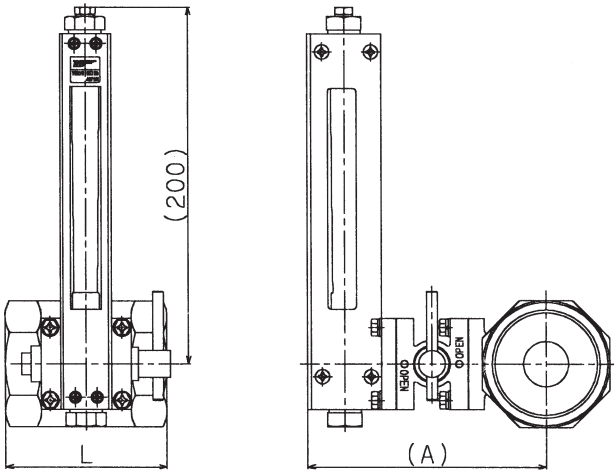

MAIN PIPE SIZE	L	*(A)	Mass (Approx.) (kg)
10mm	70	104	1.5
15mm		106	1.6
20mm		108	1.6
25mm		112	1.7
32mm	74	120	1.9
40mm	85	123	2.0
50mm	90	131	2.6

\* A is reduced by 40mm in case Isolation valve is not provided.  
Mass of Isolation valve is approximately 0.5 kg.

② MATERIAL CLASS 2, 3 (SCS14) 65mm to 100mm

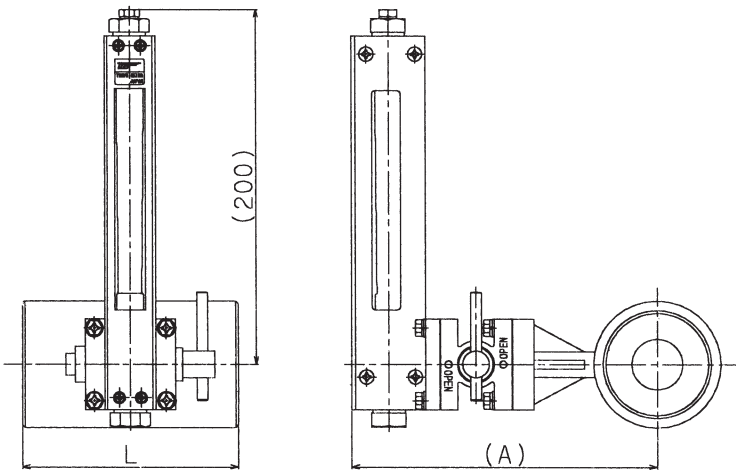

MAIN PIPE SIZE	L	*(A)	Mass (Approx.) (kg)
65mm	120	176	3.4
80mm		183	4.0
100mm	160	198	7.4

\* A is reduced by 40mm in case Isolation valve is not provided.  
Mass of Isolation valve is approximately 0.5 kg.

③ MATERIAL CLASS 4 (PVC) 10 mm to 50 mm  
MATERIAL CLASS 5 (HT-PVC) 10 mm to 40 mm

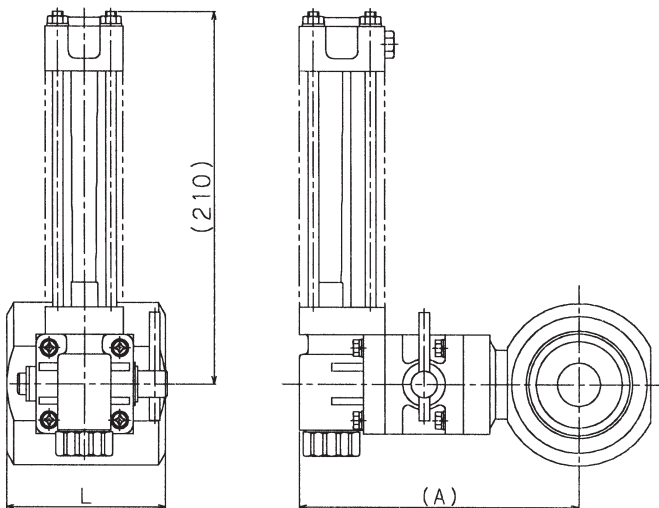

MAIN PIPE SIZE	L	*(A)	Mass (Approx.) (kg)
10mm	75	146	1.0
15mm		146	1.0
20mm		146	1.0
25mm		146	1.0
32mm	85	153	1.1
40mm		158	1.2
50mm	90	163	1.3

\* A is reduced by 44mm in case Isolation valve is not provided.  
Mass of Isolation valve is approximately 0.2 kg.



●FLANGE CONNECTION TYPE O-18□-FC-□□□-□□

MATERIAL CLASS 2, 3 (SUS304, SUS316)

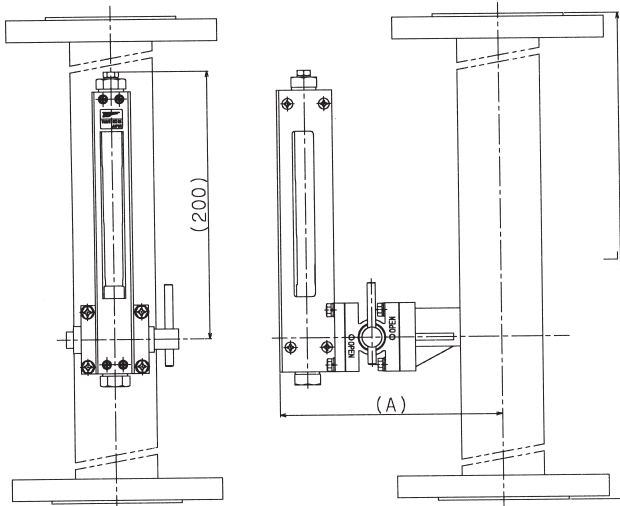

Special design with L dimension of 200mm (10mm to 80mm) and 300mm (100mm to 500mm) available on request, Contact Tokyo Keiso for details.

MAIN PIPE SIZE	Measuring tube <sup>[1], [2], [3]</sup> (SGP, SUS304, SUS316)		
	L	*1(A)	*2Mass (Approx.) (kg)
10mm	540	142	3.3
15mm		144	3.6
20mm		147	4.2
25mm		150	5.4
32mm		154	6.5
40mm		157	7.0
50mm		163	8.8
65mm		171	12
80mm		178	13
100mm		190	16
125mm		203	21
150mm		216	28
200mm		241	37
250mm		267	54
300mm		292	63
350mm		311	81
400mm		336	104
450mm		362	124
500mm		387	141

\*1: A is reduced by 40mm in case Isolation valve is not provided.

\*2: In case flange rating JIS10K Mass of the isolation valve is approximately 0.5 kg.

MATERIAL CLASS 4, 5 (PVC, HT-PVC)

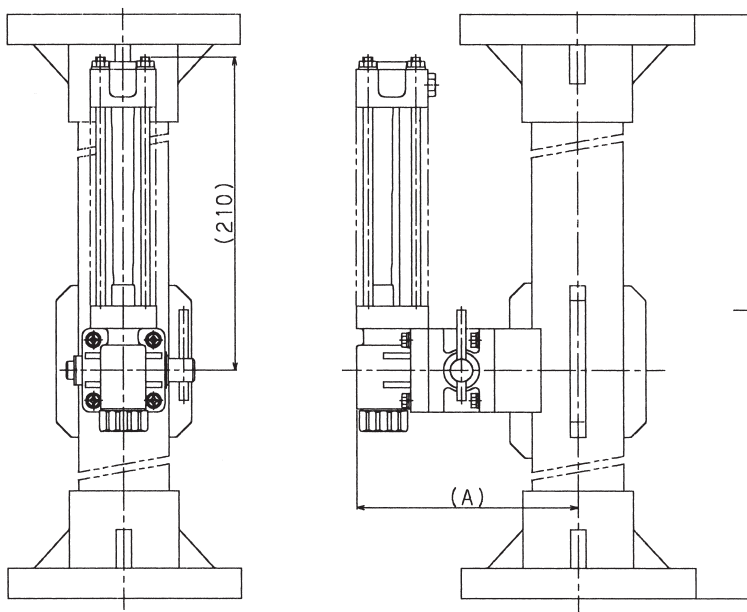

MAIN PIPE SIZE	Measuring tube <sup>[4], [5]</sup> (PVC, HT-PVC)		
	L	*1(A)	*2Mass (Approx.) (kg)
10mm	540	127	1.2
15mm		129	1.3
20mm		131	1.4
25mm		134	1.8
32mm		137	1.9
40mm		142	2.2
50mm		148	2.8
65mm		156	3.4
80mm		162	4.1
100mm		175	5.6
125mm		208	8.0
150mm		220	11
200mm		246	15
250mm		271	22
300mm		297	32

\*1: A is reduced by 44mm in case Isolation valve is not provided.

\*2: In case flange rating JIS10K Mass of the isolation valve is approximately 0.2 kg.

●WAFER CONNECTION TYPE O-18 □ -W □ - □ □ □ - □ □ □

① MATERIAL CLASS 2, 3 (SUS304, SUS316, SCS14)

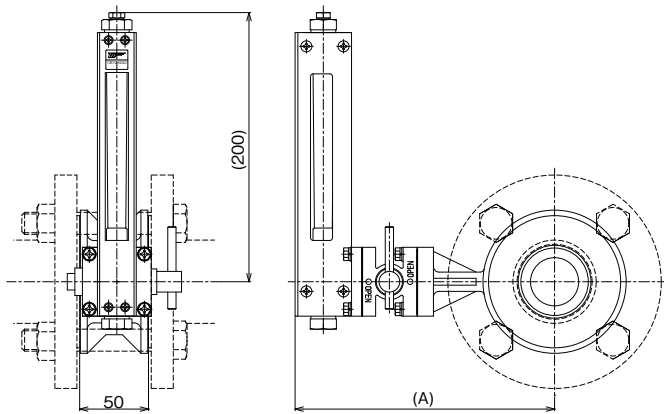

MAIN PIPE SIZE	L	*(A)	*Mass (Approx.) (kg)
10mm	50	160	2.4
15mm		162	2.6
20mm		165	2.1
25mm		173	2.2
32mm		175	2.4
40mm		181	2.4
50mm		188	2.6
65mm		198	2.9
80mm		203	3.1
100mm		216	3.7
125mm		231	5.3
150mm		246	6.2
200mm		268	7.6
250mm		300	17
300mm	322	19	
350mm	65	345	30
400mm		376	39
450mm		404	45
500mm		431	52

\* Size A and mass (approx.) are for JIS10K flange installation and is reduced by 40mm in case Isolation valve is not provided. Mass of Isolation valve is approximately 0.5 kg.

② MATERIAL CLASS 4, 5 (PVC, HT-PVC)

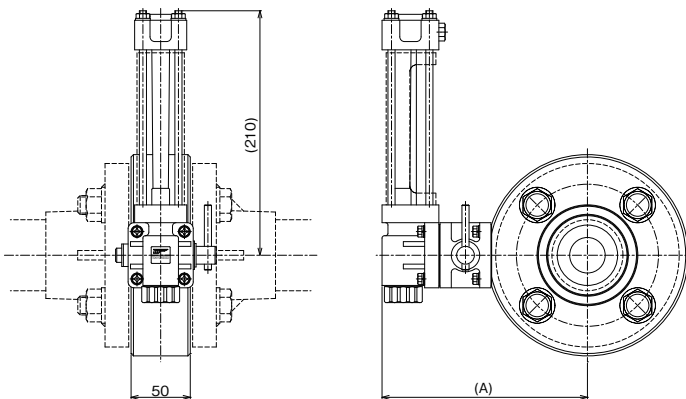

MAIN PIPE SIZE	L	*(A)	*Mass (Approx.) (kg)
10mm	50	139	1.3
15mm		141	1.3
20mm		144	1.4
25mm		158	1.7
32mm		163	1.9
40mm		166	2.0
50mm		174	2.2
65mm		184	2.5
80mm		189	2.6
100mm		202	3.0
125mm		223	3.9
150mm		238	4.6
200mm		263	5.6
250mm		298	7.8
300mm		321	8.7
350mm		344	9.4
400mm		379	12
450mm	409	14	
500mm	437	17	

\* Size A and mass (approx.) are for JIS10K flange installation and is reduced by 44mm in case Isolation valve is not provided. Mass of Isolation valve is approximately 0.2 kg.

●INDICATOR SEPARATION VERSION O-18 □ - □ B - □ □ □ - □ □

Indicator can be located separately from process by using by-pass piping for easy observation of indication. Ball valves are provided for indicator maintenance purpose. Different materials are available as shown in below table. Special design for bypass piping is available on request.

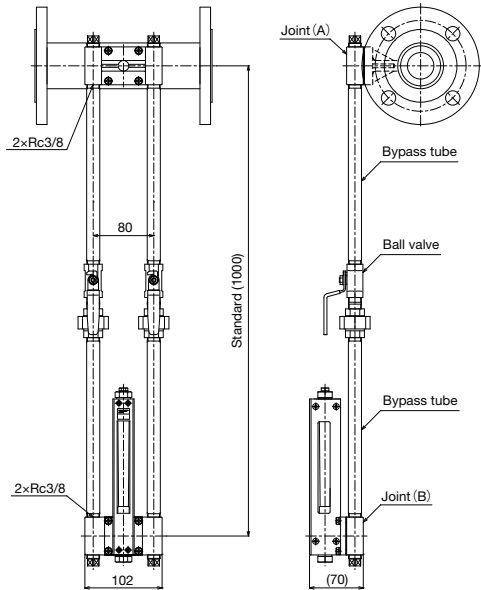

Metallic (Material 2, 3)

Part name	Material
Joint A, B	SCS14
Bypass tube	SGP (White), SUS304, SUS316
Ball valve	C3771BE, SCS13A, SCS14A

Bypass tube size will be 10mm for metal.

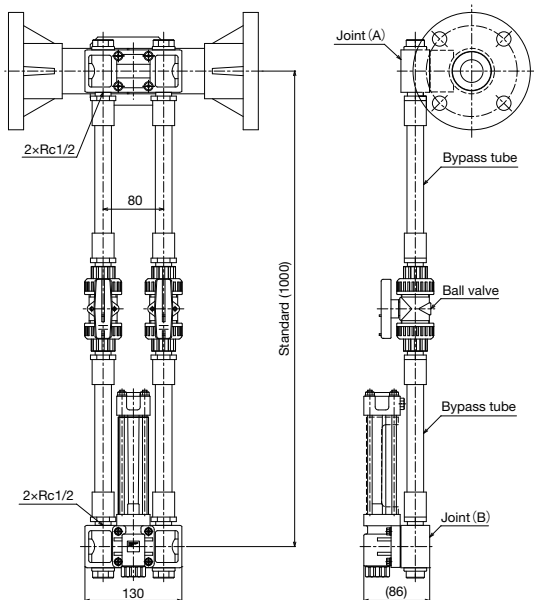

PVC-HT-PVC (Material 4, 5)

Part name	Material
Joint A, B	HT-PVC
Bypass tube	PVC, HT-PVC
Ball valve	PVC, HT-PVC

Bypass tube size will be 15mm for PVC.

●INDICATOR

① LOCAL INDICATION ONLY O-18 □

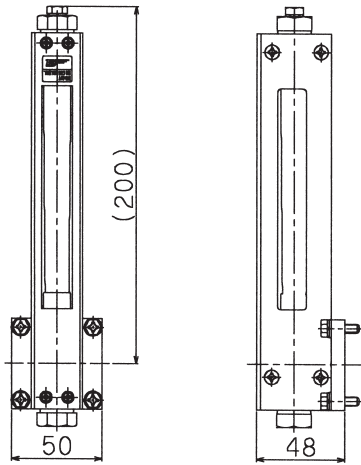

MATERIAL (SCS14)

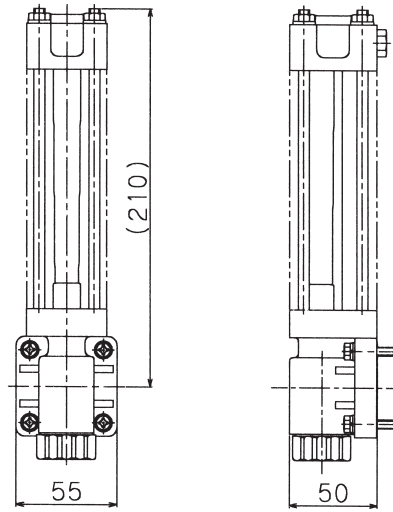

MATERIAL (PVC, HT-PVC)

② LOCAL INDICATION WITH ALARM CONTACT O-78 □

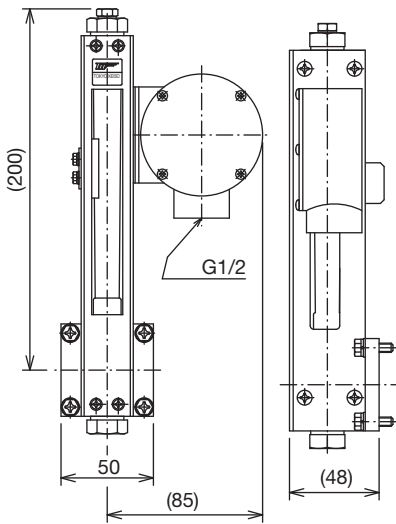

MATERIAL (SCS14)

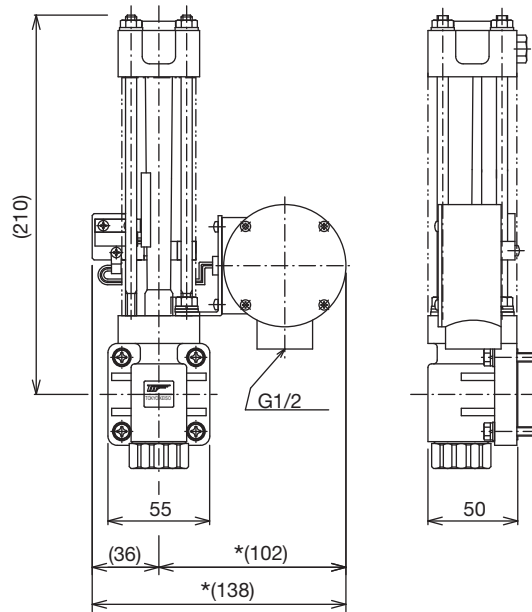

\* This dimension becomes longer by 15mm for 2-point alarm.

MATERIAL (PVC, HT-PVC)

●ISOLATION VALVE

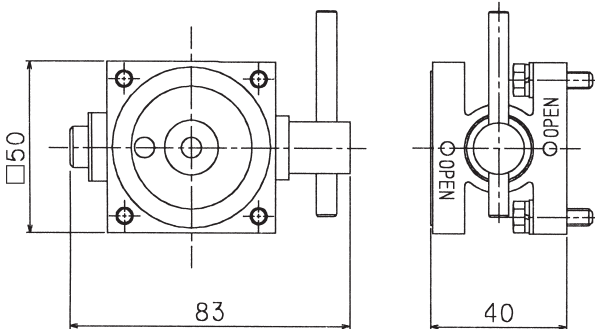

MATERIAL (SCS14)

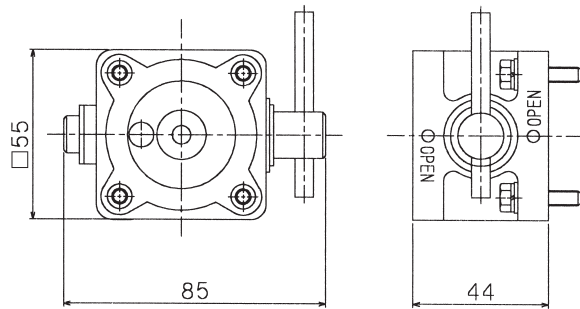

MATERIAL (HT-PVC)

## SUGGESTIONS

### (1) Upper/lower straight tube length

To obtain measurements with the predetermined accuracy, straight runs of pipes are required on both the upstream and downstream sides of the flowmeter. The required length varies depending on the piping condition and the diameter ratio; the following table shows the required length as a reference.

	Elbows and Tees	Valve (fully-opened gate valve)
Length of straight run of pipe (Upstream)	6D	8D
Length of straight run of pipe (Downstream)	3D	3D

- 'D' indicates the inside diameter of the pipe.
- The length of straight run of pipe is measured from the upstream face of the orifice plate.
- Refer to JIS Z 8762-2: 2007 for details of the straight run of pipe.

### (2) Air bubble elimination and draining

Air bubble in the indicator may cause measurement error. Eliminate the air in the indicator through Air elimination plug at the top of indicator for the start-up.

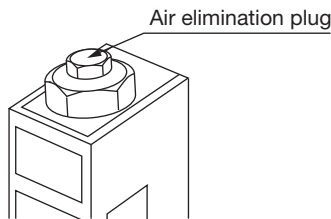

Ball valves are available for air eliminator and drain out as option as follows ;

### MATERIAL CONSTRUCTION

#### OPTION

	Ball valve/ Cock	Nipple	Shape	Method to install
Material Class 2	ASTM A351-CF8M (Equiv. to SCS14A)	SUS304		Upper and lower parts: Embedded in cap *1
Material Class 3		SUS316		
Material Class 4	PVC	-		Upper body and lower part embedded in cap *2
Material Class 5	Not applicable			

- \*1: Upper part and lower part caps differ from the standard product.  
 \*2: Upper body and lower part caps differ from the standard product.

### (3) Reading of flow rate

The flow rate is to be read by the position of float and engraved graduation. Refer to the following :

Gas application	Liquid application for local indicator
center →	top →
Alarm versions (Metallic material)	Alarm versions (PVC, HT.PVC)
top →	top →

### (4) Flow direction

By changing the direction of indicator, ORIFLO may be used for any flow direction of bottom to top, left to right, right to left and top to bottom. This change can be conducted in the field as well.

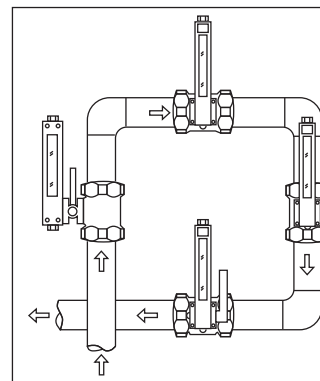

## ACCESSORIES

### (1) COUNTER FLANGES

Counter flanges are available on request. Supply scope is as follows :

Part name	Q'ty	Material
Flange	2	SUS304, SUS316
Bolt and nuts	As required	SUS304
Gaskets	2	Non-asbestos, NBR, FPM, EPDM, Others

### (2) TS FLANGES

TS socket welding flanges are also available on request :

Part name	Q'ty	Material
TS Socket welding flange	2	PVC, HT-PVC
Bolt and nuts	As required	SS400, SUS304
Gaskets	2	NBR, EPDM, Others

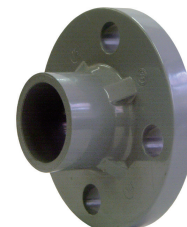

\* Specification is subject to change without notice.

---

** TOKYO KEISO CO., LTD.**

Head Office : Shiba Toho Building, 1-7-24 Shibakoen, Minato-ku, Tokyo 105-8558

Tel : +81-3-3431-1625 (KEY) ; Fax : +81-3-3433-4922

e-mail : [overseas.sales@tokyokeiso.co.jp](mailto:overseas.sales@tokyokeiso.co.jp) ; URL : <https://www.tokyokeiso.co.jp>