

O-100 Series GLASS TUBE TYPE ORIFLOMETER

GENERAL

O-100 series ORIFLO METER is a flow meter consisting of an orifice plate and a GLASS TUBE type variable area flow meter. Since the flow rate is measured with a “small sized” flow meter set to a bypass piping, the flow measurement even for “large sized” lines can be economically conducted. In addition to the local indication type, alarm contact version is also available.

STANDARD SPECIFICATION

Detection type : Bypass orifice type
 Measuring fluid : Liquids (Viscosity : up to 3mPa·s)
 and Gases
 (Not suitable for slurry and steam)

Available tapping and sizes :

- 1) D • D/2 taps (O-1□□ - □P)
100mm to 500mm
- 2) Corner taps (with orifice ring) (O-1□□ - □C)
50mm to 500mm
- 3) Flange taps (O-1□□ - □F)
50mm to 500mm
- 4) Vena contracta taps (O-1□□ - □M)
200mm to 500mm

Note : 550mm or more can be supplied on request.

Process connection : JIS5K/10K/20K, ANSI/JPI CLASS
150/300 and Others.

Temperature of liquid : Max. 120°C
 *: It is general data, and the maximum temperature may change by terms of use and environment.

Allowable thermal shock : 80°C

Fluid pressure : Max. 1.0MPa

Indication accuracy : ±3% F.S.

Paint color : Munsell 7.5BG4/1.5 (Body made of SUS not painted)

Function :

O-10□ - □□ Local indication only

O-75□ - □□ Local indication with alarm contact

Material : Refer to MATERIAL AND SCOPE OF SUPPLY for details.

Standard DP/Scale range

Range ability (standard) 10 : 2

Float material		Standard DP (kPa)	
		Liquids	Gases
Standard	Stainless steel	30	—
	Aluminum	—	10
PTFE		15	10
PVC		15	—

Custom-made meter available for more than the above DP.
 In case of custom-made meter, effective scale range is to be different.
 Refer to the maximum flow range by size, or contact us.

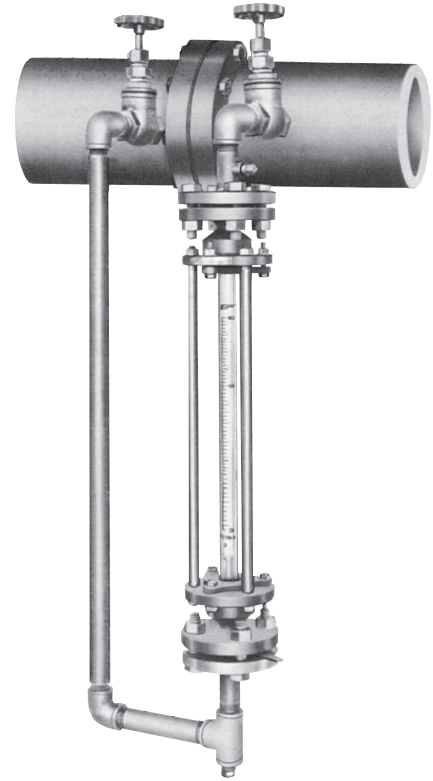

MODEL CODE

Model code				Description
O-				
Function	10			Local indication only
	75			Local indication with alarm contact
Flow direction of main pipe	1	—		Bottom to top
	6	—		Left to right
	7	—		Right to left
	8	—		Top to bottom
Position of indicator		A		Above main pipe
		B		Below main pipe
Type of tapping*1		P		D • D/2 Taps
		C		Corner taps*2 (With orifice ring)
		F		Flange taps
		V		Vena contracta taps

* 1 : Available sizes for types of tapping is to be referred to STANDARD SPECIFICATIONS.

* 2 : Orifice rings are included in scope of supply as standard.

CAPACITY OF EACH LINE SIZE

□ FOR LIQUID APPLICATIONS

Main pipe size (mm)	Flow rate Water m ³ /h (Density 1.0g/cm ³ , Viscosity 1.0mPa·S)											
	DP	10kP	*1	DP	15kP	*2	DP	30kP	*3	DP	60kP	*4
50	1.4	to	14	1.6	to	16	2.5	to	25	3.5	to	35
65	1.6	to	20	2	to	25	3	to	40	4	to	50
80	2.5	to	30	3	to	40	4	to	50	6	to	80
100	3.5	to	50	4.5	to	70	7	to	90	9	to	140
125	6	to	80	7	to	100	10	to	150	14	to	200
150	8	to	120	10	to	150	14	to	200	20	to	300
200	14	to	200	16	to	250	25	to	350	35	to	500
250	20	to	300	25	to	400	35	to	500	50	to	800
300	30	to	450	35	to	500	50	to	800	70	to	1000
350	40	to	500	45	to	700	70	to	1000	90	to	1400
400	50	to	700	60	to	900	90	to	1200	120	to	1800
450	60	to	1000	80	to	1200	120	to	1600	150	to	2000
500	80	to	1200	90	to	1500	140	to	2000	180	to	3000

*1 Resin float (PVC, PTFE), and range ability 10:2.5

*2 Resin float (PVC, PTFE), and range ability 10:2

*3 Range ability 10:2 [Resin float (PVC, PTFE), and range ability: Available up to 10:1.5]

*4 SUS float, and range ability 10:2 (Available up to 10:1.5)

□ FOR GAS APPLICATIONS

Main pipe size (mm)	Flow rate Air m ³ /h (nor) (0°C, 1 atm)								
	DP	5kP	*1	DP	10kP	*2	DP	20kP	*3
50	25	to	280	34	to	380	46	to	520
65	29	to	460	39	to	630	54	to	850
80	40	to	650	55	to	900	75	to	1200
100	67	to	1100	93	to	1500	130	to	2000
125	110	to	1600	150	to	2300	200	to	3100
150	150	to	2300	200	to	3300	280	to	4400
200	250	to	4100	350	to	5700	480	to	7800
250	390	to	6400	540	to	8800	740	to	12000
300	550	to	9200	770	to	12000	1100	to	17000
350	690	to	11000	950	to	15000	1400	to	21000
400	900	to	15000	1300	to	20000	1800	to	28000
450	1200	to	19000	1600	to	26000	2300	to	36000
500	1500	to	23000	2000	to	33000	2800	to	45000

*1 Range ability 10:2.5

*2 Range ability 10:2

*3 Range ability 10:2 (Available up to 10:1.5)

The maximum flow rate of flowmeter can be specified in the above mentioned POSSIBLE SCALE RANGE.

NOTE

1 : Above table are based on the fact that the material of main pipe is SGP (Carbon steel pipes for ordinary pipes JIS G 3452). The maximum flow rate of the main pipes other than SGP are determined by multiplying above figures by the value equal to (actual inside diameter/SGP inside diameter)² to above figures.

2 : Above table is applicable for measurement of Water (Density 1.0g/cm³, Viscosity 1.0mPa·s).

When measuring liquid whose density is not 1.0g/cm³, refer to the above table after calculating flow rate converted to air by the following formula.

$$Q_w = Q \times \sqrt{Y_o (Y_f - 1) / (Y_f - Y_o)}$$

Q_w : Flow rate converted to water

Q : Flow rate of actual fluid

Y_o : Density of actual fluidY_f : Density of float

Material	Density of float
Stainless	7.9 g/cm ³
PTFE	2.2 g/cm ³
PVC	2.5 g/cm ³

3. Airflow indicates the maximum measurable flow range based on 0°C, 1 atm. When operating conditions are different, refer to the above table after calculating flow rate converted to air by the following formula.

$$Q_A = Q \times C_Y \times C_t \times C_p$$

Q_A : Flow rate converted to air

Q : Flow rate of actual fluid

C_Y : Density conversion factor

$$C_Y = \sqrt{Y / 1.293}$$

Y : Gaseous density [kg/m³(nor)]C_t : Temperature conversion factor

$$C_t = \sqrt{(273 + t) / 273}$$

t : Temperature for actual fluid [°C]

C_p : Pressure conversion factor

$$C_p = \sqrt{0.1013 / (0.1013 + p)}$$

p : Pressure for actual fluid [MPa]

FLOW DIRECTION AND BYPASS PIPING

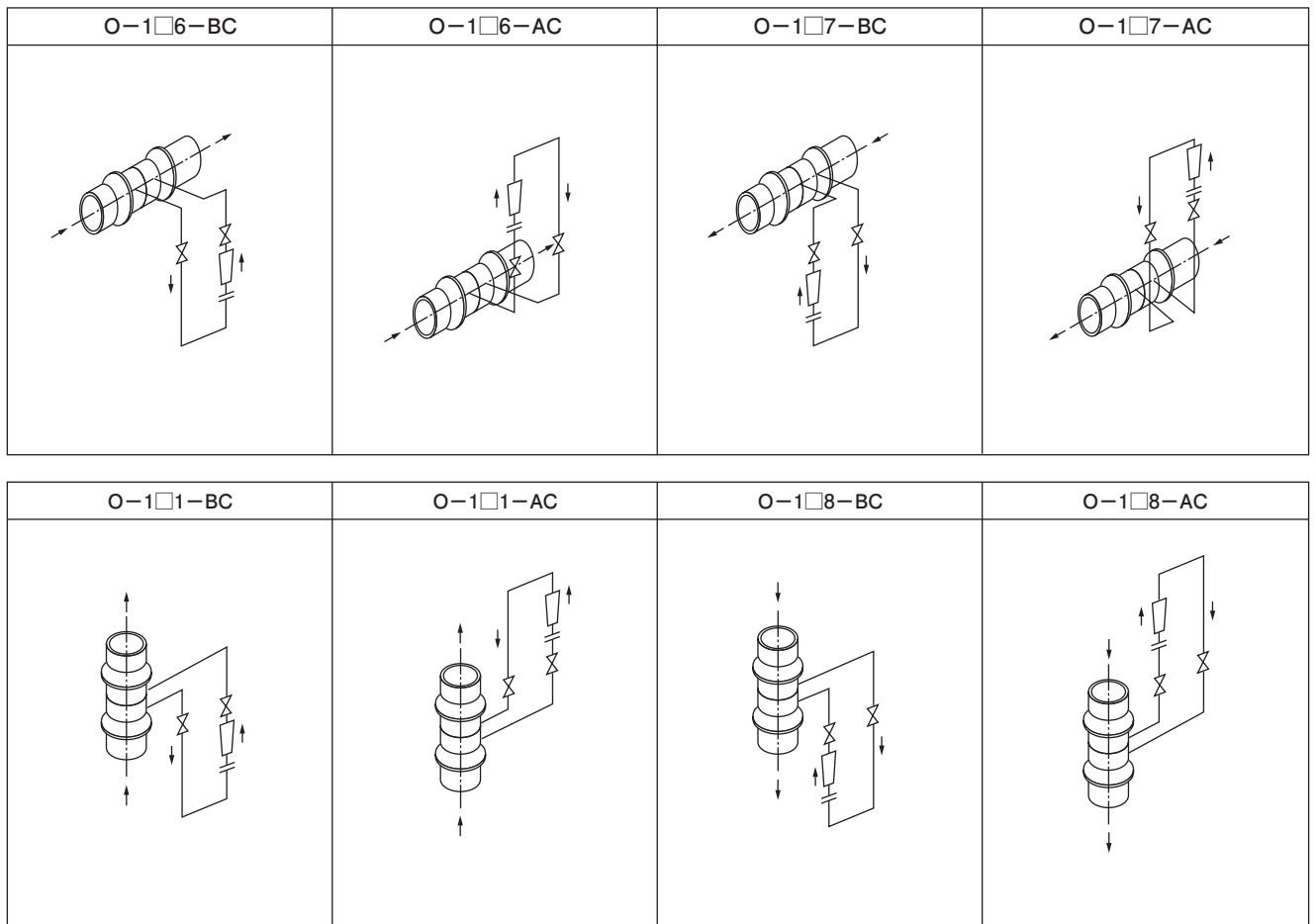

Above drawings show the case of corner tapping. The same piping configurations are applied also for other types of tappings.

STANDARD SIZES OF BYPASS PIPING (In case of Flange rating JIS10K)

(1) Corner taps (With orifice ring)

□ Horizontal piping

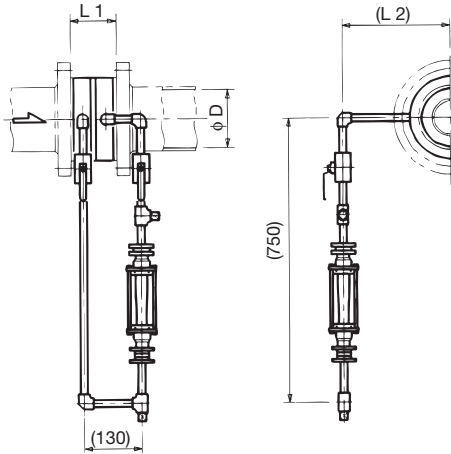

□ Vertical piping (Bottom to top)

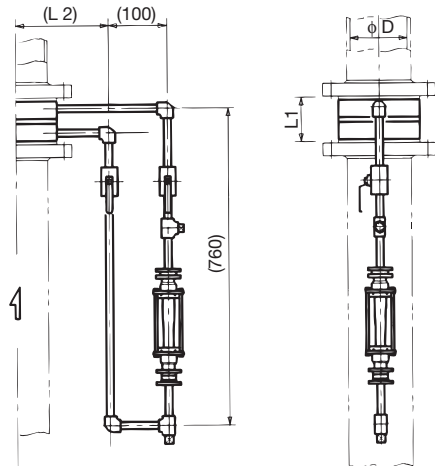

(2) D • D/2 Taps

□ Horizontal piping

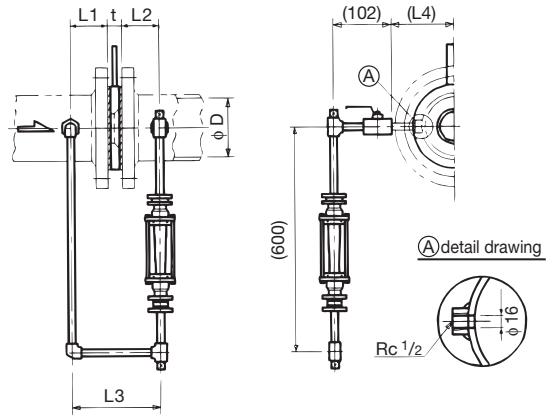

□ Vertical piping (Bottom to top)

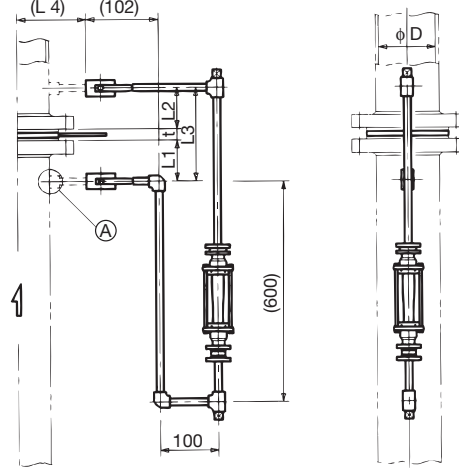

Main pipe size	L1	L2
50mm	68	125
65mm	68	135
80mm	68	140
100mm	71	150
125mm	71	165
150mm	71	180
200mm	71	205
250mm	71	245
300mm	71	265
350mm	71	290
400mm	71	325
450mm	71	355
500mm	71	380

The dimensions L1 include gasket thickness:
 t1.5mm x 2pcs for 50mm, 65mm, 80mm and
 t3mm x 2pcs for 100mm or larger.

unit : mm

Main pipe size	L1	L2	t	L3	L4
50mm	/	/	/	/	/
65mm	/	/	/	/	/
80mm	/	/	/	/	/
100mm	102	47	9	158	110
125mm	128	59	9	196	130
150mm	152	71	10	233	150
200mm	202	95	10	307	170
250mm	251	119	11	381	210
300mm	302	144	11	457	230
350mm	337	162	11	510	250
400mm	388	186	12	586	280
450mm	438	212	12	662	310
500mm	489	237	12	738	350

t includes thickness of gaskets. 3mm x 2pcs

L1 and L2 are for SGP piping.

For other piping material;

$L1=1D - 3$, $L2=1/2D - (t-3)$ where D=Pipe inside diameter

unit : mm

SUGGESTIONS FOR INSTALLATION

- Upper/lower straight tube length
 In order to make measurement in the predetermined accuracy, the straight run of tube is required. The required straight run of tube varies, depending on the diameter ratio of contraction device and the piping shape. Refer to JIS Z 8762-2: 2007.
- Since the pressure loss within the bypass pipe is precalculated, do a specified bypass piping in accordance with the related approval drawing.
- If you need bypass pipes of which sizes are different from those of standard ones due to a piping design in your factory, please contact us.

The straight run of pipe varies, depending on the piping condition and the contraction ratio of diameter, and the following is just the outline.

[Reference]

	Elbow • Tees	Valve (Gate valve fully opened)
Straight run of pipe (Upstream)	10D	12D
Straight run of pipe (Downstream)	4D	4D

- 'D' stands for the inside diameter of pipe
- Straight run of pipe means the length from the upstream face of orifice plate.

MATERIAL AND SCOPE OF SUPPLY

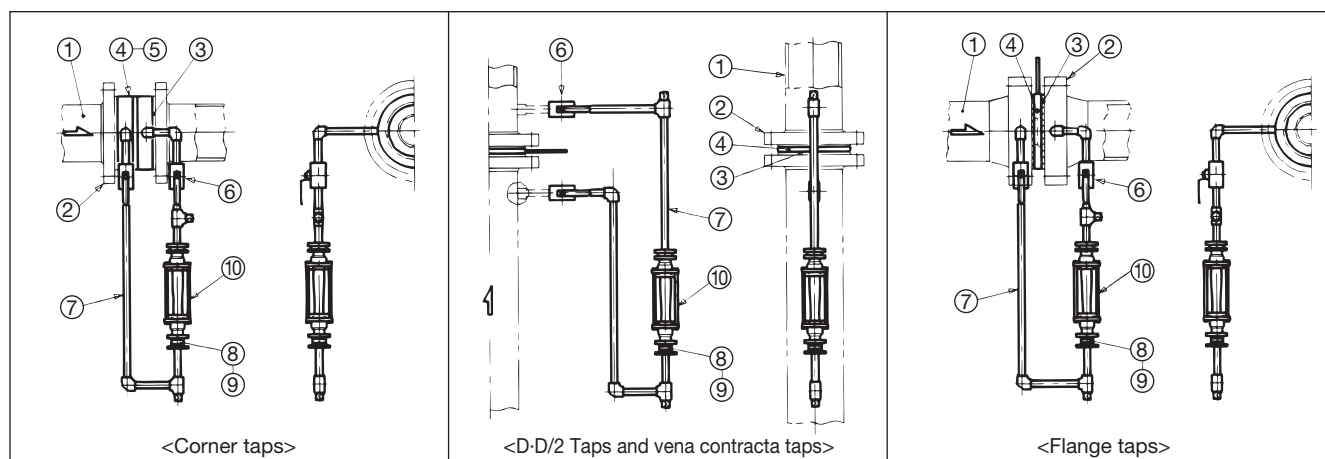

No.	Parts name	Material		
		1	2	3
①	Main pipe	Customer's supply		
②	Orifice flange	Customer's supply (Optionally available)		
	Except flange taps	S25C or SFVC2A	SUS 304	SUS 316
③	Flange gasket	Customer's supply (Optionally available)		
	Flange taps			
④	Main orifice	SUS 304	SUS 304	SUS 316
⑤	Orifice ring	SS 400	SUS 304	SUS 316
⑥	Ball valve	C3771BE	SCS 14A	SCS 14A
⑦	Bypass piping	SGP or STPG	SUS 304	SUS 316
⑧	Bypass orifice	SUS 304	SUS 304	SUS 316
⑨	Gasket	For Liquids : Non Asbestos, For Gas : NBR or FPM		
⑩	Indicator	SCS14/SS400	SCS14/SUS 304	SCS14/SUS 316

* Gaskets between Main pipe orifice (or Orifice ring) and piping flanges as well as bolts and nuts for installation are customer's scope of supply unless otherwise specified.

ORDERING INFORMATION

Model	O-10□-□□	O-75□-□□
Fluid name		
Density		
Viscosity		
Pressure		
Temperature		
Measuring range		
Material class	<input type="checkbox"/> Class 1 <input type="checkbox"/> Class 2 <input type="checkbox"/> Class 3 <input type="checkbox"/> Special ()	
Main pipe	Size	_____ mm Process connection _____
	Material	<input type="checkbox"/> SGP <input type="checkbox"/> STPG,STPT sch No. _____ <input type="checkbox"/> Stainless Steel Pipe sch No. _____ <input type="checkbox"/> Lining Pipe (ID _____ mm) <input type="checkbox"/> Others (OD _____ mm, ID _____ mm) <input type="checkbox"/> PVC (<input type="checkbox"/> VP <input type="checkbox"/> VU) <input type="checkbox"/> STPY (t _____ mm)
For O-75□-□□ (Alarm version)	Type of alarm	<input type="checkbox"/> High <input type="checkbox"/> Low
	Setting point	_____

Cautions on the use of glass tube variable area flowmeters

CAUTION

Avoid the use of glass tube variable area flowmeters for the following services.

- Liquid services subject to impulse pressure in the process.
- Secondary accidents might occur due to the breakage of glass in such services :
 - Toxic fluids such as poisons, stimulant and narcotics
 - Flammable fluids
 - Explosive fluids
- Gas handling process where breakage of glass might result in gas leakage or scattering of glass fragments.
- The installation places of the flowmeters where breakage of glass might be caused by the accidents from the surrounding piping or equipment.
- On-off operation where breakage of glass might be caused by the collision of the float inside meter due to the abrupt change of flow.
- Services where the heat shock by abrupt change of temperature is expected.

* Specification is subject to change without notice.

TOKYO KEISO CO., LTD.

Head Office : Shiba Toho Building, 1-7-24 Shibakoen, Minato-ku, Tokyo 105-8558
 Tel : +81-3-3431-1625 (KEY) ; Fax : +81-3-3433-4922
 e-mail : overseas.sales@tokyokeiso.co.jp ; URL : <https://www.tokyokeiso.co.jp>