



TECHNICAL GUIDANCE

MULTI-FUNCTION DIGITAL FLOWMETER

HDT1000 Series

OLIFLOMETER

OUTLINE

HDT1000 is a new series ORIFLOMETER combining orifice plate with multi-digital indicator.
HDT1000 detects differential pressure exerted by flow velocity on the orifice plate and displays it digitally as flow rate.
Available meter sizes range from 15mm to 300mm dia.
The principal applications are hot and cooling water, air flow measurement and so forth.

FEATURES

- ❑ Excellent cost performance
Flow rate measurement is possible at low cost for medium or large diameter pipes.
- ❑ Compact design
The indicator part is very small and saves mounting space.
- ❑ Easy installation
Available various process connections of "Screw", "Flange", and "Wafer" to meet all field possible requirements and for easy pipe installation.
- ❑ Applicable for both parallel and vertical pipes.
- ❑ Various functions of indicator
 - Any type can be chosen out of the following:
Battery type, Current output type (2-wire 4-20mA DC) and Alarm output type
 - Indicator part is interchangeable
- ❑ Easy to see because of large LCD display

MAIN APPLICATIONS

- ❑ Air conditioner water and air line
- ❑ Cooling water line
- ❑ General process line in medium and large diameters
- ❑ Sewage disposal process
- ❑ Pure water device
- ❑ Fire pump performance test
- ❑ Blower performance test

INDICATOR SPECIFICATION

Refer to the DT series TECHNICAL GUIDANCE [TG-EM125E](#) for the details of digital indicator.

STANDARD SPECIFICATION

- Measuring Fluid : Liquid (equivalent to water) or Gas
- Pressure condition
Fluid pressure : Max. 2MPa
Allowable differential pressure: 200kPa (one-sided)
(700kPa for a differential pressure range of 5kPa or more)
Incompatible with negative pressure



- Temperature and Relative Humidity
Fluid temperature : -10 to 70°C
Ambient Temp. : -10 to 50°C < 85%RH
Storage Temp. : -20 to 60°C < 85%RH
(Without icing, without condensation)
- Main pipe size : 15mm to 300mm
(350 to 500mm ; Consult factory for details)
- Flow range : Refer to [FLOW RANGE]
- Process connection
Screw connection : Rc thread
NPT thread
[Main pipe size 15mm (1/2") to 100mm (4")]
Flange connection : JIS5K/10K/20K FF/RF
ANSI/JPI CLASS 150/300
[Main pipe size 15mm (1/2") to 300mm (12")]
Wafer connection : JIS5K/10K/20K
ANSI/JPI CLASS 150/300
[Main pipe size 15mm (1/2") to 300mm (12")]
- Indication accuracy : ±3% F.S.
- Measuring range : Flow rate from 10 to 100% of full scale
- Low cutoff : Less than 7%
- Protection class : IP65 (JIS C 0920)
(Except the air introduction port at the bottom of housing.)
- Material : Refer to [MATERIAL]
- Painting
Measuring tube : Polyurethane painting
(No painting in case of stainless steel)
Indicator housing : Melamine resin painting
- Painting color
Measuring tube : Jade green (Munsell 7.5BG4/1.5)
Indicator housing
Front : Wine red (Munsell 10RP3/8)
Rear : Light gray (Munsell N7.5)
- Installation posture : Front vertical installation

● Upper/lower straight tube length

In order to make measurement in the predetermined accuracy, the straight run of tube is required. The required straight run of tube varies, depending on the diameter ratio of contraction device and the piping shape. Refer to JIS Z 8762-2: 2007.

The straight run of pipe varies, depending on the piping condition and the contraction ratio of diameter, and the following is just the outline.

[Reference]

	Elbow•Tees	Valve (Gate valve fully opened)
Straight run of pipe (Upstream)	10D	12D
Straight run of pipe (Downstream)	4D	4D

- 'D' stands for the inside diameter of pipe
- Straight run of pipe means the length from the upstream face of orifice plate.

● Indicator type function (All types with indicator)

Type	Function
Battery type	Battery drive, Indication only
Current output type	4-20mA DC (2-wire)
Alarm output type	2 points + 4-20mA DC
	Alarm 1-point +totalized pulse + 4 to 20 mA

● Indication function

- Flow rate indication : 3-1/2 digits LCD (Height 18mm) : 0 to 1999 (FFF appears in case of out of range)
11 segment bar graph
- Totalizer indication : 7-1/2 digits LCD (Height 5mm) : 0 to 19999999
- Indication interval : 1s (Sampling 0.5 sec)
- Filter : 0,2,4,8,16,32s (Moving average)
- LCD back light : Continue 10s after operation (Except current output type)

● Specification and function of each type

1) Battery type

- Battery : Alkali battery (LR6) x 2 pcs.
- Battery life : Approx. 2 years at 23°C
Auto power off mode selectable
Low Battery monitor as standard

2) Current output type

- Power supply : 24V DC±10%
- Output : 4-20mA DC (2-wire)
- Max. load : 600Ω
- Output accuracy : ±0.5% F.S. at 23°C
- Response : Less than 2 s (At filter setting 0)

3) Alarm output type

- Power Supply : 24V DC ±10%
- Power Consumption: Less than 25mA
- Alarm Output : Open Collector x 2 (Independent)
(When the totalized pulse output option is added, the alarm output can be set only at either a high or low limit.)
- Totalized pulse output: Pulse width : 200 to 300ms
Frequency : Less than 1Hz
- Load : Less than 30V DC / 80mA
- Response : Less than 2 s (At Filter setting 0)
- Alarm setting : Selectable (high / Low),
Reset Span: Adjustable / Min. 1digit
- Output : 4-20mA DC
- Max. load : 600Ω
- Output Accuracy : ±0.5%F.S.at 23°C

● Cable entry

Type	Cable entry
Battery type	—
Current output type	○
Alarm output type	○
Acceptable cable outside diameter	Ø3-8mm

○ : Yes — : No

OPTION

- Totalizing indication
Selection of totalizer function
CODE : TLZ
- Totalized indication + Pulse output
CODE : PUL

CAUTIONS ON INSTALLATION

- Avoid direct rays and equip with a protection cover or install in the place which a direct rainstorm does not splash.
(If protection cover is used, it may be difficult to read the display.)

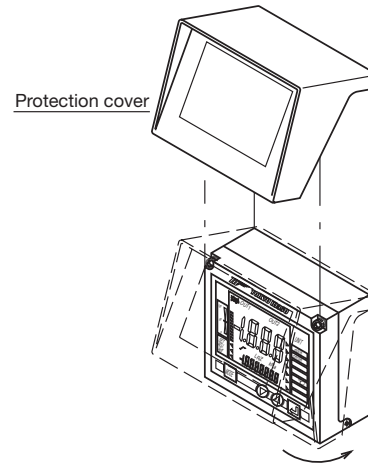

CAUTIONS FOR INSTALLATION ORIENTATION

- Install the measuring tube with the indicator display perpendicular to the ground.
Horizontal installation may cause inaccuracy or malfunction.

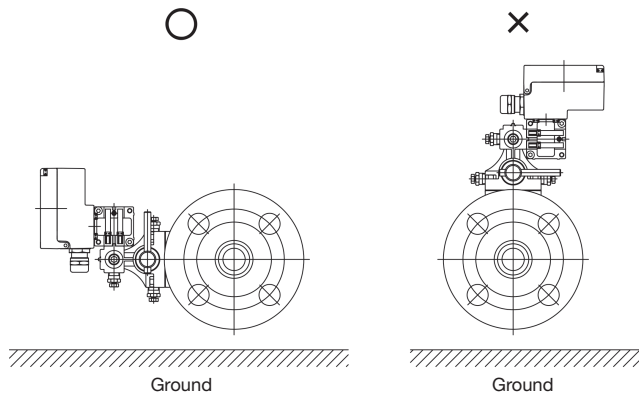

MATERIAL

Part Description		Material class 2		Material class3		
Wetted parts	Measuring tube	Screw connection	15~100mm	SCS14	15~100mm	SCS14
		Flange connection	SUS304		SUS316	
			Wafer connection	15~200mm for JIS10K	SCS14	15~200mm for JIS10K
		Others	SUS304	Others	SUS316	
	Orifice plate		SUS304		SUS316	
	Isolation valve	Body	SCS14		SCS14	
		Shaft	SUS316		SUS316	
		O ring	NBR or FPM		NBR or FPM	
	Indicator	Diaphragm	SUS316L			
		Body	SUS316			
O ring		FPM				
Drain hole seal		Alumina ceramics				
Indicator body		Aluminum alloy				

FLOW RANGE

Main pipe size	Maximum flow rate			
	Liquid m ³ /h		Gas m ³ /h (nor)	
	(Density 1.0g/cm ³ , Viscosity 1.0mPa·s)		(0°C·1atm Air)	
	Min.	Max.	Min.	Max.
15 mm	0.23	2.3	3.4	37
20 mm	0.31	5.2	4.6	85
25 mm	0.45	8.8	5.5	140
32 mm	0.51	14.7	6.7	230
40 mm	0.69	19	8.6	320
50 mm	0.75	32	10	520
65 mm	1.2	53	15	860
80 mm	1.7	74	21	1200
100 mm	2.9	127	35	2000
125 mm	4.4	196	54	3200
150 mm	6.2	276	80	4500
200 mm	11	480	140	7800
250 mm	17	740	210	12000
300 mm	24	1060	300	17200

- ◆ The maximum flow rate of upper table are for liquid application equivalent to water (Density 1.0g/cm³ and Viscosity 1.0mPa·s). If actual fluid condition has different values, conversion calculation is required per following formula:

$$Q_w = Q \times \sqrt{\gamma}$$

Q_w : Water converted flow rate

Q : Flow rate of actual fluid

γ : Density of actual fluid (g/cm³)

- ◆ The calculation of figures in the above flow range table has been made on the premises that SGP, a JIS code name for a carbon steel pipe for ordinary piping, is used for main pipes. In case of main pipes other than SGP, multiply the above liquid quantity by (the inner diameter of the main pipe used ÷ the inner diameter of a SGP pipe)².

- ◆ The maximum flow rate for gas of upper table are shown by the flow rate of AIR, at 0°C, 1atm. If actual fluid condition has different value, conversion calculation is required per following formula.

Conversion calculation

$$Q_A = Q \times C_\gamma \times C_t \times C_p$$

Q_A : Converted Air flow

Q : Flow rate of Actual Gas

C_γ : $C_\gamma = \sqrt{\gamma/1.293}$

[γ = Density of the Gas, kg/cm³(nor)]

C_t : $C_t = \sqrt{(273+t)/273}$

(t = operating temp., °C)

C_p : $C_p = \sqrt{0.1013/(0.1013+p)}$

(p = Operating press, MPa)

OUTLINE DIMENSION

- Screw connection type
Material class 2 / 3 (Main pipe size 15~50mm)

[Installation in the case of Gas]
Each connection in common

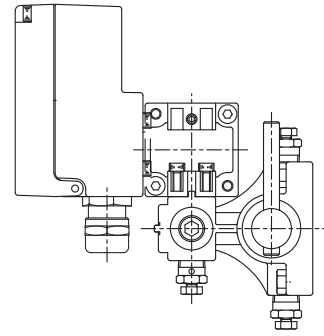
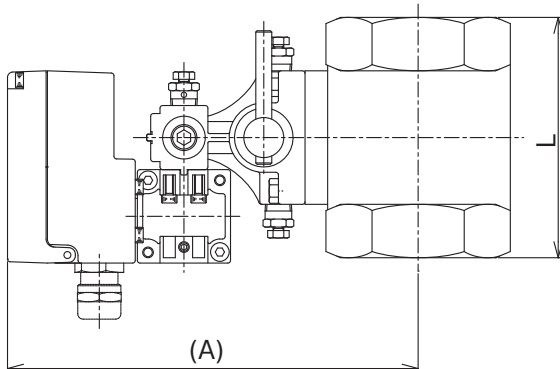
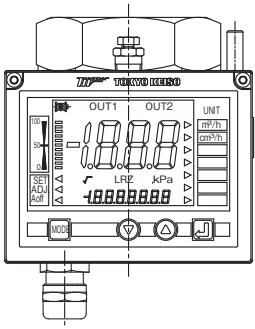

This outline dimension is for the liquid measurement. An indicator is fixed at the top of isolation valve in case of gas measurement.

[Dimension of indicator]

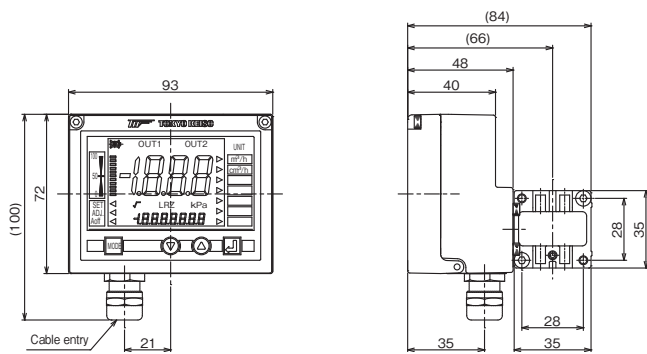

Main pipe size	L	A	Mass (Approx.) (kg)
15mm	70	130	1.9
20mm	70	132	1.9
25mm	70	136	2.0
32mm	74	144	2.2
40mm	85	147	2.4
50mm	90	155	2.9

- Screw connection type
Material class 2 / 3 (Main pipe size 65~100mm)

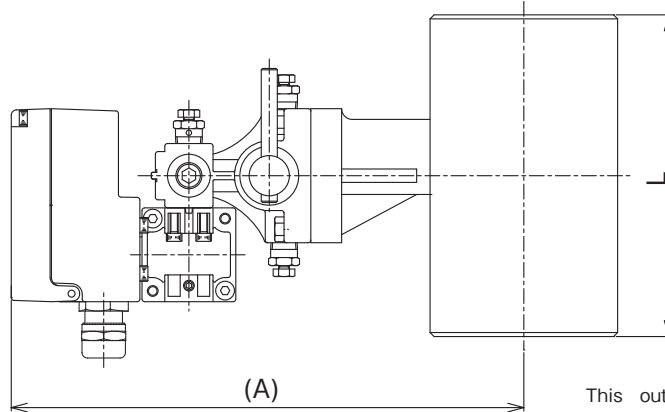
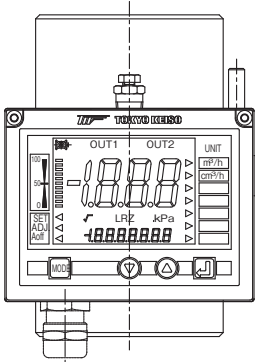

This outline dimension is for the liquid measurement. An indicator is fixed at the top of isolation valve in case of gas measurement.

Main pipe size	L	(A)	Mass (Approx.) (kg)
65mm	120	199	3.7
80mm	120	207	4.4
100mm	160	222	7.7

● Flange connection type

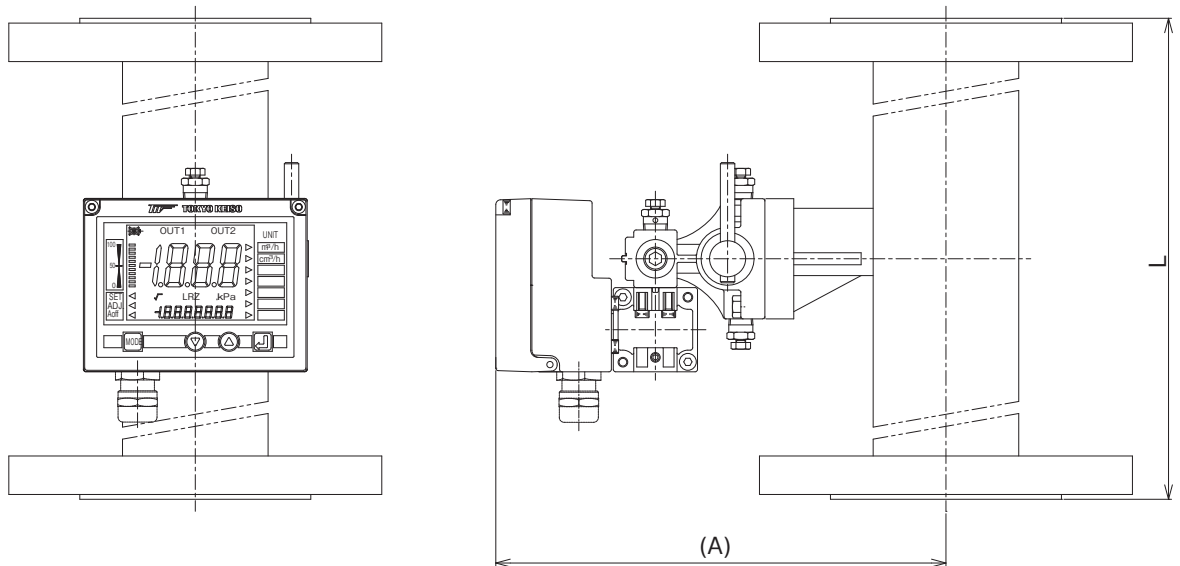

This outline dimension is for the liquid measurement. An indicator is fixed at the top of isolation valve in case of gas measurement.

Main pipe size	L	(A)	Mass (Approx.) (kg)*	Main pipe size	L	(A)	Mass (Approx.) (kg)*
15mm	540	167	3.9	80mm	540	201	13
20mm	540	170	4.5	100mm	540	214	16
25mm	540	174	5.7	125mm	540	226	21
32mm	540	178	6.8	150mm	540	239	28
40mm	540	181	7.3	200mm	540	265	37
50mm	540	187	9.1	250mm	540	290	55
65mm	540	195	12	300mm	540	316	63

*Mass (Approx.) is for case of JIS10K flange.

● Wafer connection type

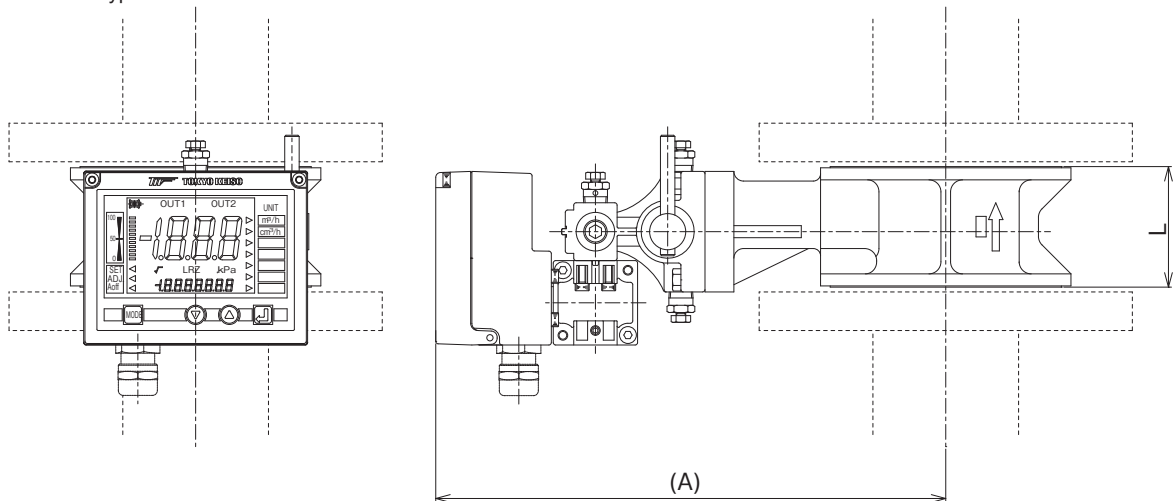

This outline dimension is for the liquid measurement. An indicator is fixed at the top of isolation valve in case of gas measurement.

Main pipe size	L	(A)*	Mass (Approx.) (kg)*	Main pipe size	L	(A)*	Mass (Approx.) (kg)*
15mm	50	186	2.9	80mm	50	227	3.4
20mm	50	188	2.4	100mm	50	239	4.0
25mm	50	197	2.5	125mm	50	255	5.6
32mm	50	199	2.7	150mm	50	270	6.6
40mm	50	204	2.7	200mm	50	292	7.9
50mm	50	212	2.9	250mm	50	323	18
65mm	50	222	3.2	300mm	50	346	20

*A Length and Mass (Approx.) are for case of JIS10K flange.

- Indicator separation version

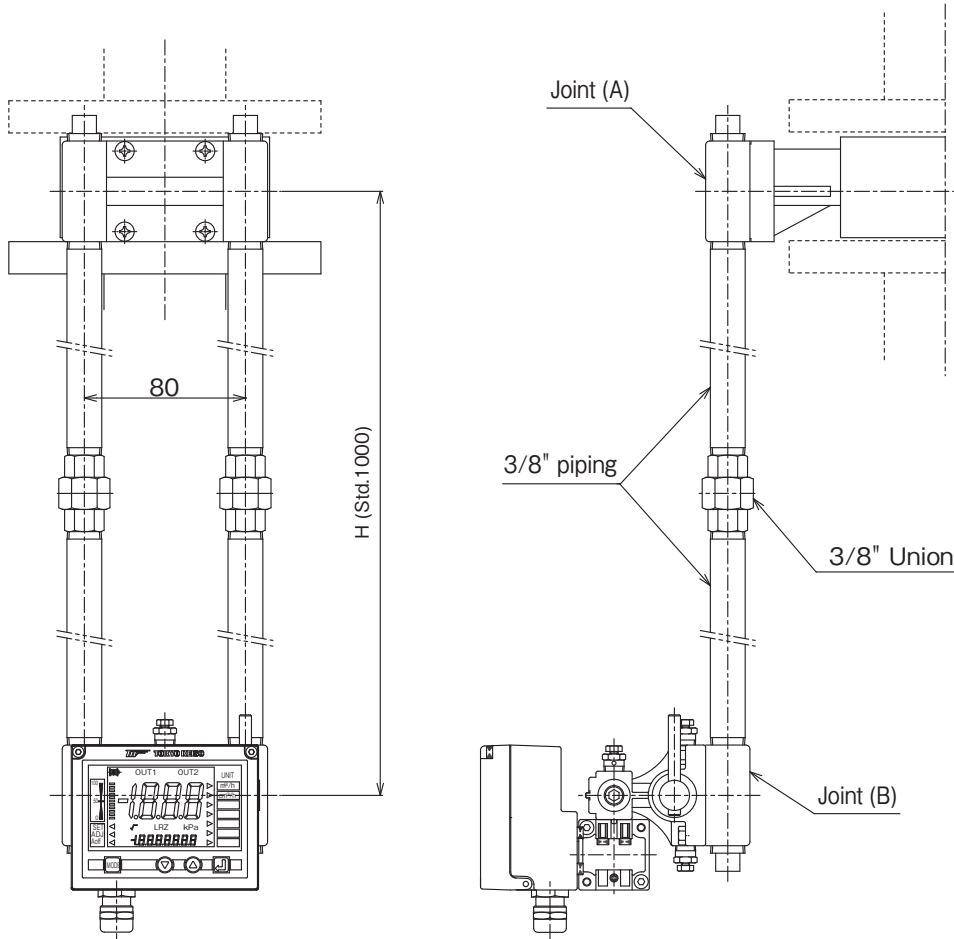

This outline dimension is for the liquid measurement. An indicator is fixed at the top of isolation valve in case of gas measurement

Indicator can be located separately from process by using extension piping for easy observation of indication. Extension piping length is 1000mm (std). (Extension piping length is available on request)

Part description	Material class2	Material class3
Joint (A)/(B)	SCS14	SCS14
3/8B Pipe	SUS304	SUS316
3/8B Union	SCS13A	SCS14A

Refer to MATERIAL table for the combination of material class 2, and 3.

WIRING DIAGRAM

[Current output type]

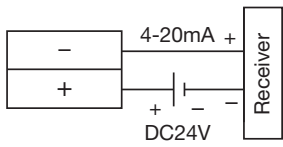

[Alarm output type]

Alarm output (1)/(2) : Open collector
Max. 30V DC/80mA

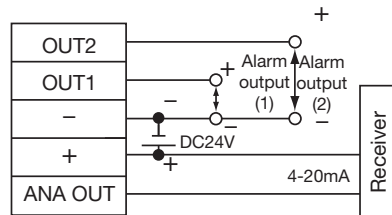

(OUT1 is used for the pulse output when the totalized pulse output option is added.)

MODEL CODE

Model code										Description	Note			
HDT1	□□□	-□□□	□	-□	□	□	□□□	□	□	-A	/□□□			
Main pipe size	015											15mm		
	∅											∅		
	300											300mm		
Process connection		-SRC										Thread connection Rc		
		-SNP										Thread connection NPT		
		-J1F										JIS10K FF Flange		
		-J1R										JIS10K RF Flange		
		-J2F										JIS20K FF Flange		
		-J2R										JIS20K RF Flange		
		-J5F										JIS5K FF Flange		
		-J5R										JIS5K RF Flange		
		-A1R										ANSI 150 Flange		
		-A3R										ANSI 300 Flange		
		-P1R										JPI 150 Flange		
		-P3R										JPI 300 Flange		
		-WJ1										Wafer (JIS10K)		
		-WJ2										Wafer (JIS20K)		
		-WJ5										Wafer (JIS5K)		
		-WA1										Wafer (ANSI 150)		
		-WA3										Wafer (ANSI 300)		
		-WP1										Wafer (JPI 150)		
	-WP3										Wafer (JPI 300)			
	-ZZZ										Others			
Material			2									Material class 2	Refer to MATERIAL table	
			3									Material class 3		
Indicator installation				-1								With isolation valve		
				-2								Indicator separation version		
O-ring for isolation valve					N							NBR		
					F							FPM		
Flow direction												1	Bottom to Top	
												6	Left to Right	
												7	Right to Left	
												8	Top to Bottom	
Flow range*1												***	Flow range code	Manufacturer choice
Indicator type												4	Battery type	Battery drive
												5	Current output type	4-20mA DC (2-wire)
												6	Alarm output type	2 points + 4-20mA DC
Application												L	For Liquid	
												G	For Gas	
Version												-A	Version code	
Option												/TLZ	Totalization indication	
												/PUL	Totalized indication + Pulse output	Applicable for alarm output type only.
Additional function												(Blank)	Not provided	Not necessary if above-mentioned code is available.
												/Z	Provided	

*1 Flow range code is selected by factory in accordance with the specified maximum flow rate and diameter.

Code example 1: [In case optional code is not selected.]

25mm diameter. Thread connection Rc. Material class 2. With isolation valve. NBR for O-ring for isolation valve.

Flow direction: Left to right. Battery operated type. For liquid application. "HDT1025-SRC2-1N6***4L-A"

Code example 2: [In case all of the possible optional codes are selected.]

50mm diameter. JIS10K FF flange connection. Material class 2. With isolation valve. NBR for O-ring for isolation valve.

Flow direction: Top to bottom. Current output type. For liquid application. Totalization indication added.

"HDT1050-J1F2-1N8***5L-A/TLZ"

Code example 3: [In case the face to face dimension is specified.]

80mm diameter. JIS5K FF flange connection. Material class 3. With isolation valve. NBR for O-ring for isolation valve.

Flow direction: Right to left. Current output type. For liquid application. Totalization indication added. L=600 is specified instead of L=540.

"HDT1080-J5F3-1N7***5L-A/TLZ/Z" (L=600)

When the face to face dimension is specified as seen in the above Code Example 3, it will be "Special specification", and the last letter of model code will be "Z" in case of such special specification as not mentioned in the above model code.

CONSTRUCTION

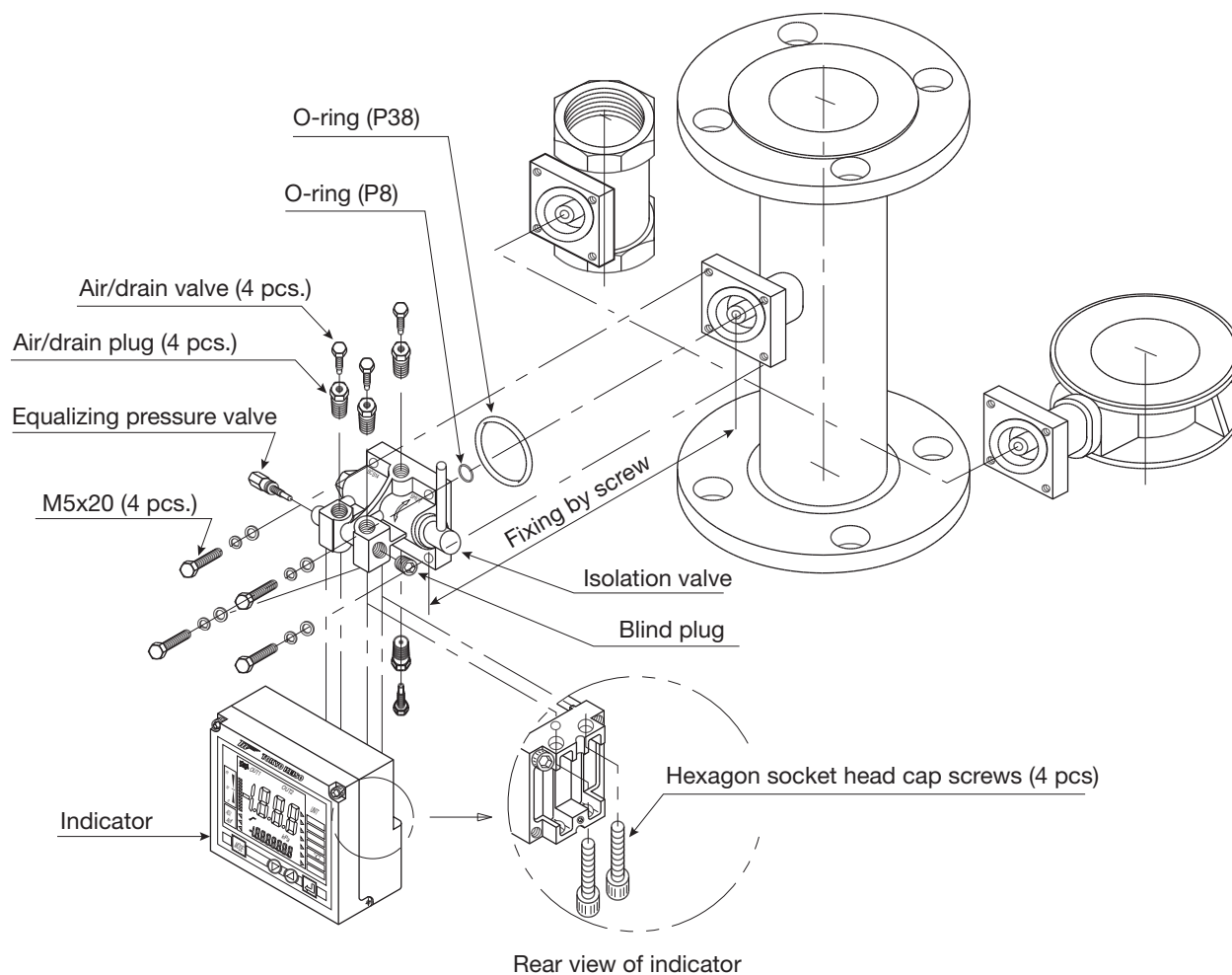

PREPARATION OF MEASUREMENT

- In case the fluid is liquid, eliminate the air, and for the gas application, eliminate the drain in according to the HDT1000 Instruction manual [IM-F972].

ORDERING INFORMATION

1. MODEL
2. FULL SCALE
3. FLUID NAME
4. TEMPERATURE (Nor. Max.)
5. PRESSURE (Nor. Max.)
6. DENSITY
7. VISCOSITY

* Specification is subject to change without notice.

TOKYO KEISO CO., LTD.

Head Office : Shiba Toho Building, 1-7-24 Shibakoen, Minato-ku, Tokyo 105-8558
 Tel : +81-3-3431-1625 (KEY) ; Fax : +81-3-3433-4922
 e-mail : overseas.sales@tokyokeiso.co.jp ; URL : <https://www.tokyokeiso.co.jp>