



# TECHNICAL GUIDANCE

FOR MULTIPOINT LEVEL ALARM DETECTION BY ONE UNIT

## FP-4000 Series

### FLOAT LEVEL SWITCH

#### OUTLINE

The FP-4000 series is a float level switch, which is installed through the tank nozzle on tanks and/or pits. Level alarm detection is possible at up to 11 points (up to 6 points for the flameproof version). This switch can be used to control loading/unloading pumps and monitor High-high and Low-low level alarms, saving total instrumentation costs.

In addition to the standard stainless steel material for wet parts, other materials such as PVC, HPVC, PP and fluorocarbon resins are also available. Thus, the switch can be used for monitoring and controlling the level of ordinary water, waste water, chemicals and highly corrosive liquids. Besides weatherproof type, flameproof and intrinsic safety versions are available for use in hazardous area.

#### MAIN APPLICATIONS

- Preventing overflow of liquids and idle suction by pumps
- Controlling loading/unloading pumps
- Monitoring the liquid level of underground tanks/pits

#### STANDARD SPECIFICATION

Measuring objects : Any liquids with a viscosity of 600 mPas or less  
No freezing, adhesion, or coagulation

Minimum liquid density: See "Float details & outside dimensions of body."

Liquid temp. :

a. Model FP-4000 and FP-4100

Wetted part material	Material code	Liquid temp. range
SUS304,316,316L	0 1 2 3	-5 to 100°C (Special: -20 to 150°C)
PVC	4	0 to 60°C
H PVC	5	0 to 80°C
PP	6	0 to 60°C
PFA	7	0 to 100°C

b. Model FP-4200

Wetted part material	Material code	Liquid temp. range
SUS304,316,316L	0 1 2 3	-10 to 80°C
PVC	4	0 to 60°C
H PVC	5	0 to 80°C
PP	6	0 to 60°C
PTFE	7	-5 to 80°C
PFA	8	0 to 80°C

Ambient temperature : -20 to 70°C  
-20 to 55°C (Flameproof)  
-20 to 60°C (Intrinsic safety)

Pressure range :

Model FP-4000 and FP-4100 See float details.  
Model FP-4200 See float details.

Connection :

Model FP-4000 and FP-4100 SUS/PVC:50A to 200A (2B to 8B), flange  
PFA: 80A to 200A (3B to 8B), flange  
Thread connections such as G2 and R2 are also available excluding PFA. Contact us for details.

Model FP-4200 80A to 200A (3B to 8B), flange  
Refer to it for each model.

Max length of guide pipe :

Enclosure :

Model FP-4000 Weatherproof or intrinsic safety  
(Relay barrier installed separately)

Model FP-4100 and FP-4200 Weatherproof, flameproof\*<sup>1</sup> or  
intrinsic safety (Relay barrier  
installed separately)

Protection code : Equiv. to IP65

\*<sup>1</sup>Class : Exd II BT6 (RIIS, Japan)

Model FP-4100 TC14695-14697

Model FP-4200 TC14698-14700



FP-4000

FP-4100

FP-4200

Alarm contract : Reed switch

Contact setting : Specify ON or OFF (HC or HO) for float rising, and ON or OFF (LC or LO) for float falling for each contact.

Contact capacity :

Model FP-4000 and FP-4100 50 W

Max. switching voltage

220 V AC, 110 V DC

Max. switching current

0.7 A

Model FP-4200

10 W AC/DC

Max. switching voltage

125 V AC, 100 V DC

Max. switching current

0.5 A

A surge suppressor is provided except for the intrinsically safe version.

Repeatability : Within ±5 mm

Reset span : 10 mm or less

No. of alarm point:

Model Wiring	FP-4000	FP-4100	FP-4200
Independent	3	6	6
Common return	5	11* <sup>2</sup>	11* <sup>2</sup>

\*<sup>2</sup>: Special order

Cable entry : Model FP-4000: One entry (either G1/2 or G3/4)

Model FP-4100 and FP-4200:

One entry (G3/4) as standard

Max. two entries on request

Adapters will be provided when different sizes or NPT connection are designated.

Flameproof cable glands are available on request for use in hazardous areas. Use the following cable gland to conform to explosionproof standards.

Designated cable gland: Model SXC-22B by Shimada Electric, which is suitable for cables with a diameter of 12 to 13.9 mm. For other cable sizes, specify a cable diameter among 8 to 9.9, 10 to 11.9, or 14 to 15.9 mm to select a proper cable gland.

Cable termination :

Model FP-4000 M4 screw

Model FP-4100 and FP-4200 M3.5 screw

Finish : Aluminum part Silver

Stainless steel No paint

Approved products for High Pressure Gas Safety Act are available. Consult us for details.



OUTSIDE DIMENSION

Float details & outside dimensions of body

Material of float		SUS316L		PVC	HPVC	PP	PFA/NBR	
Allowable pressure [MPa]		0.66		0.13		0.2	0.2	
(Standard) Withstand pressure test [MPa]		0.8 *4		0.2		0.3	0.3	
Allowable minimum liquid density [g/cm <sup>3</sup> ]		0.6	0.78	1.0	0.75	1.0	0.79	1.3
Di- men- sion [mm]	Diameter of guide pipe (d)	13.8		18		22	16	
	Maximum outside diameter of float(D)*1	52	43 *7	42	48 *7	50	68.2	42.6
	Inside diameter of float	15.4		20		25	19	
	Height of float (H)	58	50	70		60	100	50
Minimum h1 dimension [mm]		60		90		140	80	
Minimum interval (S) [mm]		100	90	120 *5		150	100	
Minimum L dimension Lowest end point + X [mm] *2		X=60		X=90		X=140	X=80	
Outside drawing *3 ① Terminal box ② Flange ③ Guide pipe ④ Float ⑤ Stopper		<p>Material code 0 1 2 3</p>		<p>Material code 4 5 6</p>		<p>Material code 7</p>		

- \*1: Confirm that the float can be inserted into the nozzle.
- \*2: Can be reduced depending on liquid density and the operation of contacts. Contact us for details.
- \*3: The number of floats and stoppers in figures may differ for smaller intervals.
- \*4: The test will be carried out at 1.0 MPa for floats with a design pressure from 0.53 to 0.66 MPa.
- \*5: Available from 100 mm by special order (see \*3)
- \*6: Max. length of the guide pipe

Structure	Material			
	SUS	PVC	PP	PFA
Weatherproof (W)	4900	3900	3900	3900
Intrinsic safety (S)				
Flameproof (E)	3900			

- \*7: Floats come in this size unless another size is specified.
- \*8: G1/2 is applied as standard.



OUTSIDE DIMENSION

Float details & outside dimensions of body

Material of float		SUS316L		PVC	HPVC	PP	PFA/NBR	
Allowable pressure [MPa]		0.66		0.13		0.2	0.2	
(Standard) Withstand pressure test [MPa]		0.8 *4		0.2		0.3	0.3	
Allowable minimum liquid density [g/cm <sup>3</sup> ]		0.6	0.78	1.0	0.75	1.0	0.79	1.3
Di- men- sion [mm]	Diameter of guide pipe (d)	13.8		18		22	16	
	Maximum outside diameter of float(D)*1	52	43 *7	42	48 *7	50	68.2	42.6
	Inside diameter of float	15.4		20		25	19	
	Height of float (H)	58	50	70		60	100	50
Minimum h1 dimension [mm]		60		90		140	80	
Minimum interval (S) [mm]		100	90	120 *5		150	100	
Minimum L dimension Lowest end point + X [mm] *2		X=60		X=90		X=140	X=80	
Outside drawing *3 ①Terminal box ②Flange ③Guide pipe ④Float ⑤Stopper		<p>Material code 0 1 2 3</p>		<p>Material code 4 5 6</p>		<p>Material code 7</p>		

- \*1: Confirm that the float can be inserted into the nozzle.
- \*2: Can be reduced depending on liquid density and the operation of contacts. Contact us for details.
- \*3: The number of floats and stoppers in figures may differ for smaller intervals.
- \*4: The test will be carried out at 1.0 MPa for floats with a design pressure from 0.53 to 0.66 MPa.
- \*5: Available from 100 mm by special order (see \*3)
- \*6: Max. length of the guide pipe [mm]

Structure	Material			
	SUS	PVC	PP	PFA
Weatherproof (W)	4900	3900	3900	3900
Intrinsic safety (S)				
Flameproof (E)	3900			

\*7: Floats come in this size unless another size is specified.



OUTSIDE DIMENSION

Float details & outside dimensions of body

Material of float		SUS316L	PVC	HPVC	PP	PFA/NBR
Allowable pressure [MPa]		0.13	0.13		0.13	0.13
(Standard) Withstand pressure test [MPa]		0.2	0.2		0.2	0.2
Allowable minimum liquid density [g/cm <sup>3</sup> ]		0.7	0.8	0.8		0.9
Di- men- sion [mm]	Diameter of guide pipe (d)	21.7	26	27		25
	Maximum outside diameter of float(D) *1	75	70	70		68.2
	Inside diameter of float	24	29	29		27.7
	Height of float (H)	70	100	100		100
Minimum h1 dimension [mm]		100	150	150		150
Minimum interval (S) [mm]		50	50	50		50
Minimum L dimension Lowest end point + X [mm] *2		X = 100	X = 150		X = 150	
Outside drawing *3 ① Terminal box ② Flange ③ Guide pipe ④ Float ⑤ Stopper		<p>Material code [0][1][2][3]</p>	<p>Material code [4][5][6]</p>	<p>Material code [8]</p>		

\*1: Confirm that the float can be inserted into the nozzle.

\*2: Can be reduced depending on liquid density and the operation of contacts. Contact us for details.

\*3: Max. length of the guide pipe [mm]

Structure	Material			
	SUS	PVC	PP	PFA
Weatherproof (W)	4900	3900	3900	3900
Intrinsic safety (S)	4900	3900	3900	3900
Flameproof (E)	3900			

OUTSIDE DIMENSION

With outer cylinder chamber

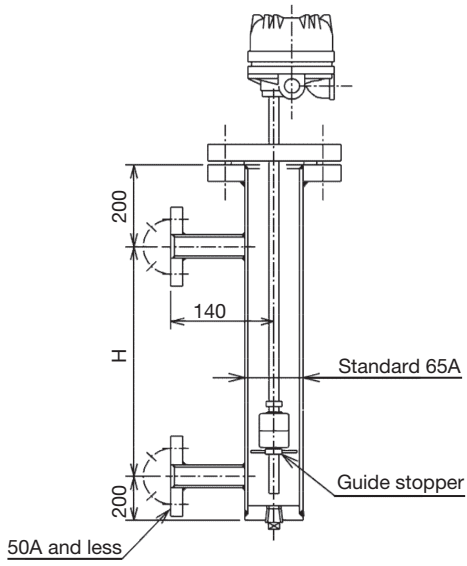

H: Face-to-face dimension

With inner-cylinder chamber

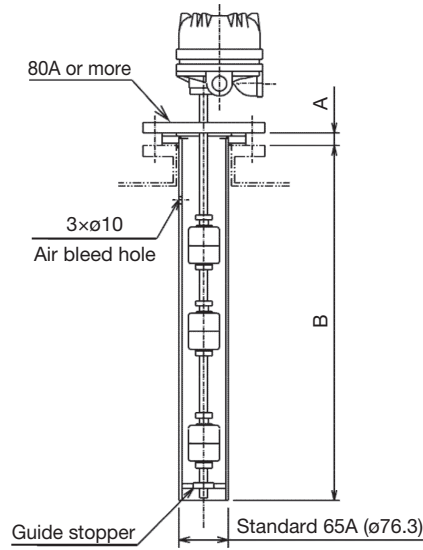

A: 15mm + gasket thickness x2  
 B: Between nozzle flange and chamber lower end

We can manufacture a float level switch with an outer- or inner-cylinder chamber on request.

If you prepare the outer- or inner-cylinder chamber, we can install a guide stopper.

\* Specification is subject to change without notice.

**TOKYO KEISO CO., LTD.**

Head Office : Shiba Toho Building, 1-7-24 Shibakoen, Minato-ku, Tokyo 105-8558  
 Tel : +81-3-3431-1625 (KEY) ; Fax : +81-3-3433-4922  
 e-mail : overseas.sales@tokyokeiso.co.jp ; URL : <https://www.tokyokeiso.co.jp>