

FC-100 series is a piping direct connection type CONTROL VALVE made of stainless steel, and best for the flow rate control of the cooling lines of semiconductor process, chiller unit etc.

OUTLINE

FC-100 series is a compact, integral flow control unit for water. This unit consists of two devices. One is FCV-200 which is for measurement and control with valve in wheel flowmeter, and other is FCA-110 which is a controller detecting and calculating the flow rate signal in order to control setting flow rate.

An axial flow type flowmeter has been adopted and the control valve has been built in, so that the direct connection with piping can be made. The controller has the functions to make calculation after receiving the signal from flowmeter and then to convert it to the control signal. Thus, the space saving and the improvement of noise-proof performance have been realized.

FEATURES

- ❑ Space saving
The functions of flow rate conversion and control are stored in this compact unit, and the valve is integrated into flowmeter, resulting in making it compact.
The connection with piping can be directly made because the flow path is straight.
- ❑ Flow control for energy saving
Not only for mere flow control, flow control for the optimal condition of equipment can be performed.
The flow control by an external signal enables to keep the flow rate at minimum and to save energy.
- ❑ Complete shutoff of valve
It is possible to shutoff the valve, thus making it easy to make maintenance.
- ❑ Water removing and air purging
It was impossible to perform "Water removing and air purging" with the conventional wheel flowmeter, but thanks to the adverse flow prevention guide of a wheel, the number of processes before shipment has been reduced sharply.
- ❑ Environment-friendly product
Lead-free solder has become a reality. Flowmeter and also each part, as well as a controller, used for the valve part consist of components corresponding to RoHS instructions, and this flow control valve is environment-friendly.
- ❑ EMC Compatible standard
EN61326-1
- ❑ Usage
The stable flow setting can be performed without being influenced by the mutual intervention between lines because a control unit has been installed in each line branched from the main piping.

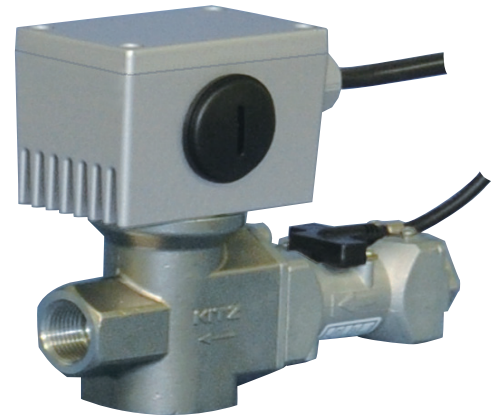

Control valve
FCV-200



Controller
FCA-110

- ❑ Control accuracy and performance
FC-100 series is the control unit having the feedback control system which measures a flow rate and outputs the drive signal to move the control valve to the arbitrary position. Therefore, it is possible to control it within $\pm 3\%$ of a maximum flow rate within about 5 seconds.
- ❑ Data of flow control measurement (Target flow rate 20-90%, Pressure 0.4MPa)

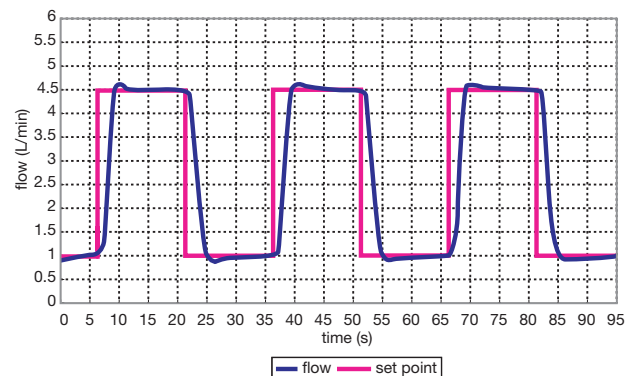

NEW DEVELOPMENT BY FLOW CONTROL!

- ❑ Are you in trouble with the fluctuation of flow rate?
- ❑ Do you wish fine flow control of water lines?
- ❑ Flow control of small flow from 0.5L/min is available.
- ❑ Controlling flow rate makes your product value-added remarkably.
- ❑ Flow rate control by external signal is attained.
- ❑ Yield rate for manufacturing can be improved by controlling a flow rate.
- ❑ Don't you change your equipment into environment-friendly one by keeping flow rate minimum?

EXAMPLES

<Example 1>

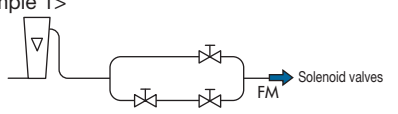

● The line was controlled by On/Off of a solenoid valve...

<Example 2>

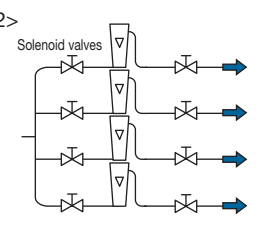

● It was difficult to keep constant flow at each branch line of complicated piping system because of interference.

Preset signal Analog signal

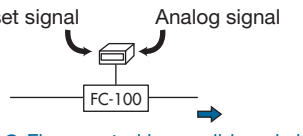

● Flow control is possible only by FC-100 series.

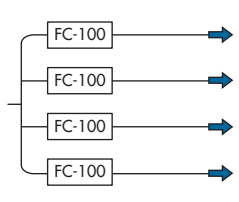

● The flow rate of each line can be kept constant.

MAIN APPLICATIONS FC-100 is applicable to various kinds of apparatus such as semiconductor and FPD manufacturing equipment.

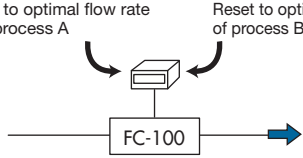
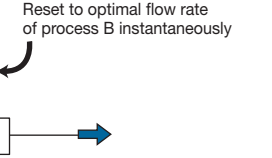
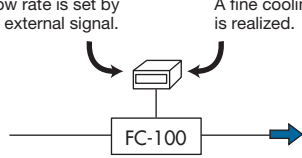
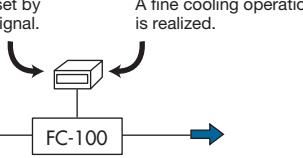
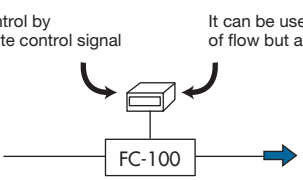
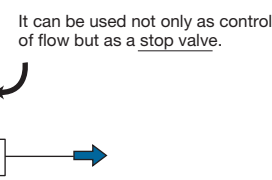
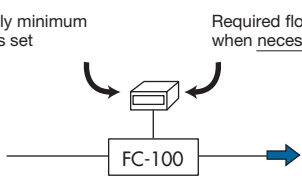
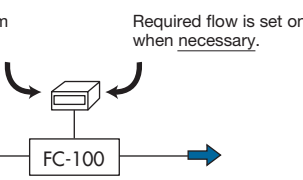
| | |
|--|---|
| <p style="text-align: center;">Flow control for water lines</p> <p>FC-100 series flow control valve assures fine flow control instead of annoying manual operation.</p> <div style="display: flex; justify-content: space-around;"> <div style="text-align: center;"> <p>Set to optimal flow rate of process A</p>  </div> <div style="text-align: center;"> <p>Reset to optimal flow rate of process B instantaneously</p>  </div> </div> | <p style="text-align: center;">Flow control by external signal</p> <p>Not only control at fixed set-point, the equipment is operated at optimal conditions by optimal setting of flow.</p> <div style="display: flex; justify-content: space-around;"> <div style="text-align: center;"> <p>Flow rate is set by an external signal.</p>  </div> <div style="text-align: center;"> <p>A fine cooling operation is realized.</p>  </div> </div> |
| <p style="text-align: center;">Application as a stop valve</p> <p>Since it is possible to close a valve completely by external signal, it can be used as a stop valve for maintenance.</p> <div style="display: flex; justify-content: space-around;"> <div style="text-align: center;"> <p>Flow control by a flow-rate control signal</p>  </div> <div style="text-align: center;"> <p>It can be used not only as control of flow but as a <u>stop valve</u>.</p>  </div> </div> | <p style="text-align: center;">Flow control for energy saving</p> <p>Flow control at required flow rate without wasting resources.</p> <div style="display: flex; justify-content: space-around;"> <div style="text-align: center;"> <p>Usually minimum flow is set</p>  </div> <div style="text-align: center;"> <p>Required flow is set only when necessary.</p>  </div> </div> |

CAUTIONS

- 1) Do not install this control valve in reverse flow direction.
- 2) Do not use this control valve for piping with big pulsation.
(For example, discharge line of diaphragm pump etc.)

Model

1) Standard specification (Controller, Flowmeter, Valve set)

| Model | Flow rate | Connection size |
|----------------|----------------|-----------------|
| FCV-205A-3/8 | 0.5 to 5 L/min | 3/8 |
| FCV-210A-3/8 * | 1 to 10 L/min | 3/8 |

* The connection size of Model for more than 10L/min is to be more than \varnothing 10mm.

Product code

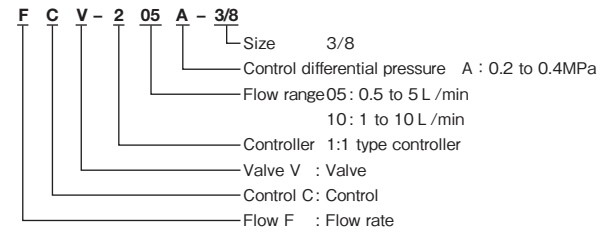

Control valve (FCV series) specification

1) Basic specification

| Model | Description | |
|------------------------------------|---|--------------------------------------|
| | FCV-205A-3/8 | FCV-210A-3/8 |
| Connection size | 3/8 | 3/8 |
| Resisting pressure | 0.5MPa | |
| Controllable differential pressure | 0.2 to 0.4MPa | |
| Control flow rate range | 0.5 to 5 L/min | 1 to 10 L/min |
| Cv value | 0.3 | 0.6 |
| Type of flowmeter | Axial flow wheel type (TW-090 series) | |
| Piping connection | Rc3/8 | |
| Fluid temperature | 0 to 60°C (Without freezing) | |
| Ambient temperature and humidity | 0 to 50°C / 85%RH (Without freezing) | |
| Full open and close time | Approx. 5 sec. | |
| Construction | Valve part | Equivalent to IP54 (Except air hole) |
| | Flowmeter | Equivalent to IP65 |
| Applicable fluid | Cooling water or low viscosity liquids (2mPa•s or less) Anticorrosive liquid | |
| Power supply | Valve part | DC24V 700mA |
| | Flowmeter | DC24V 50mA |
| Output of flowmeter | Open collector pulse DC24V 15mA | |
| Wiring connection | Connection with a specification electric wire | |
| Response time | Approx. 5 sec. | |
| Accuracy | \pm 3%F.S. | |

Refer to TW-080/090 series Technical Guidance for detailed specification of flowmeter.

INSTALLATION POSTURE

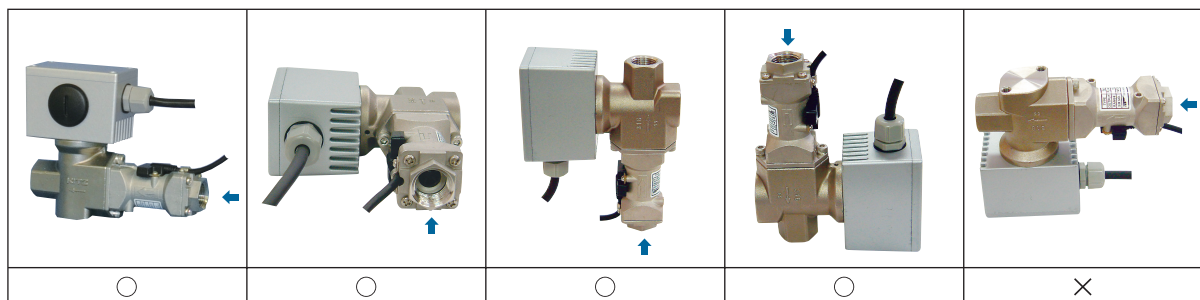

○ : Recommendation

× : Not applicable

CONTROLLER SPECIFICATION (FCA-110)

1) Rating

| Item | Description |
|-----------------------|---|
| Power supply | DC24V \pm 10% |
| Consumption current | 0.6A |
| Dielectric strength | AC500V (50/60Hz) at 1 min. or AC600V (50/60Hz) at 1 sec. |
| Insulation resistance | DC500V mega More than 20M Ω |
| Sampling period | 0.1 sec. |
| Ambient temperature | 0 to 50°C |
| Storage temperature | 0 to 50°C |
| Relative humidity | 35 to 85%RH |

2) Structure

| Item | Description |
|---------------------------------|--|
| Dimension | DIN 24 × 48 Depth 80mm |
| Case material | Conversion polyphenylene ether |
| Body color | Front panel: Front seal Body: Grey |
| Construction Connection type | Panel for operation: Weatherproof (Equivalent to IP54) Cramp type terminal, Connector |
| Fixing method | Panel mount with both-ends screw M3 |
| Front panel | Four buttons "MODE", "Horizontal movement", "Vertical movement", "ENT." |
| Main indication | 5 digit, 7 segment LED indication for flow rate or setup, etc. |
| Status display | 3 points LED Alarm indication 2 points (Red) Control indication 1 point (Green) |

3) Input and Output

| Item | Description | Reference |
|--------------------------------|--|--|
| Input of external setup signal | DC4 to 20mA, DC1 to 5V, DC0 to 10V | Multi-correspondence |
| RS-485 input and output | For manufacturer setup | — |
| Alarm output | Open collector 2 points Contact capacity (DC30V, 1A) | a,b contact selectable b contact: Output is OFF when power supply is OFF. |
| Abnormal output of valve | Open collector 1 point Contact capacity (DC30V, 1A) | a,b contact selectable b contact: Output is OFF when power supply is OFF. |
| Flow rate signal output | DC4 to 20mA, DC1 to 5V, DC0 to 10V Accuracy \pm 1% (F.S.) Response time: Less than 25ms | At the time of the low control by controller or communication, signal value is arbitrarily selectable. The signal becomes same as an external input signal at the time of the flow control by an external input signal. |
| External control start / stop | "Control" starts by short-circuiting START and COM of an external input, and it stops by opening | — |
| Forcible stop | By short-circuiting CLOSE and COM of an external input, the valve can be forcibly closed. | — |

FCV-200 CONTROL VALVE DIMENSION

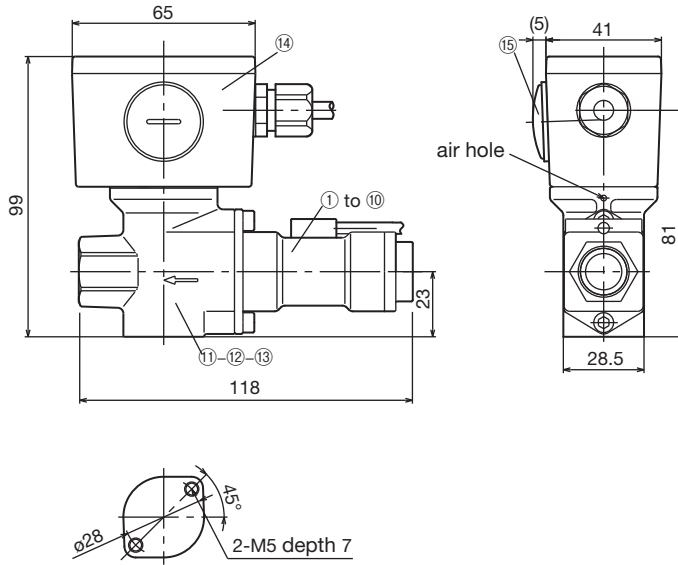

Standard material

| NO. | Parts name | Standard material |
|-----|-----------------|------------------------------|
| 1 | Wheel | Ferrite + Nylon 12 |
| 2 | Shaft | ZrO ₂ + PBT |
| 3 | Ball bearing | ZrO ₂ |
| 4 | Whirlpool guide | PBT |
| 5 | Flow path | SCS14 |
| 6 | O-ring | Fluororubber |
| 7 | Circuit board | -- |
| 8 | Cover | ADC12 |
| 9 | Set screw | SUS304 |
| 10 | Cable | PVC (Corresponding to UL) |
| 11 | Valve | SCS14 |
| 12 | Valve spindle | SUS316 |
| 13 | O-ring | Fluororubber |
| 14 | Housing | ADC12 |
| 15 | Cap | Nylon66 |

FCA-110 CONTROLLER DIMENSION

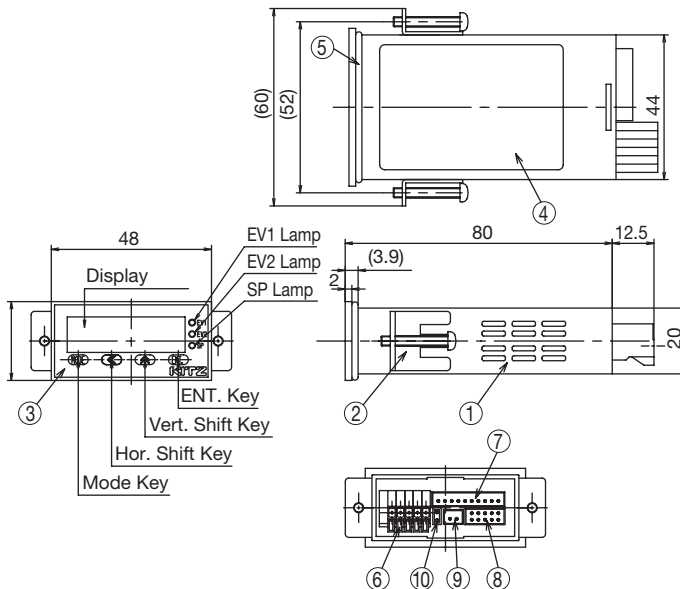

| No. | Part Name | Remark |
|-----|-------------------|------------------------------|
| 1 | Case | Denatured polyphenyleneethyl |
| 2 | Fitting | -- |
| 3 | Operation sheet | -- |
| 4 | Connection label | -- |
| 5 | Waterproof rubber | -- |
| 6 | Terminal block | Spring type connection |
| 7 | Connector CN3 | 10-pin, 1-row |
| 8 | Connector CN4 | 10-pin, 2-row |
| 9 | Connector CN5 | 2-pin |
| 10 | Short-circuit pin | -- |

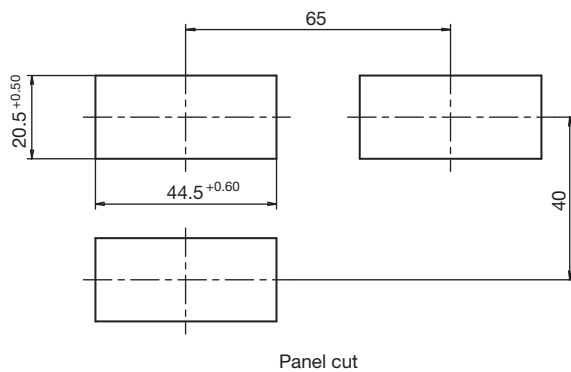

Functions of Switches and Lamps

| Name | Function |
|--------------------|--|
| Mode switch | Mainly used to shift among the menu items. |
| Hor. Shift switch | Mainly used to shift the digit when entering a numerical value. |
| Vert. Shift switch | Mainly used to change a numerical value when entering it. |
| ENT. switch | Mainly used to settle a set item. |
| SP lamp | Blinks during flow rate control and illuminated while flow rate control is stabilized. |
| EV1 lamp | Mainly illuminated during EV1 output. |
| EV2 lamp | Mainly illuminated during EV2 output. |

ATTACHMENT CABLE (①, ②: Accessories, ③: Option)

① External Output Cable

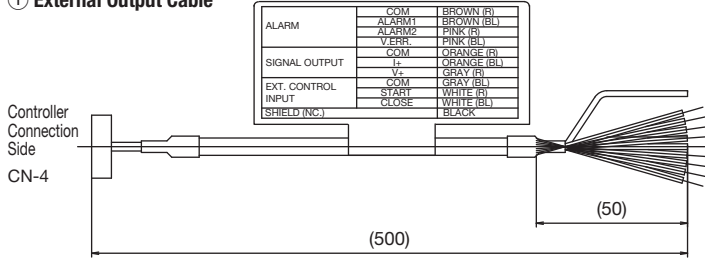

② Device Connection Cable

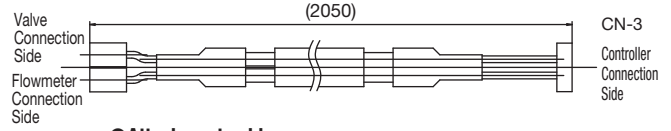

- Attachment cable
 - ① External Output Cable : 0.5m, 1piece
 - ② Device Connection Cable : 2m, 1piece
- (For connection of a controller and valve)

③ Device Connection Extension Cable

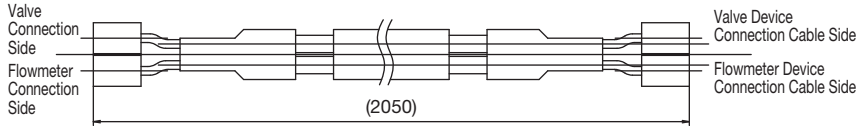

WIRING DIAGRAM

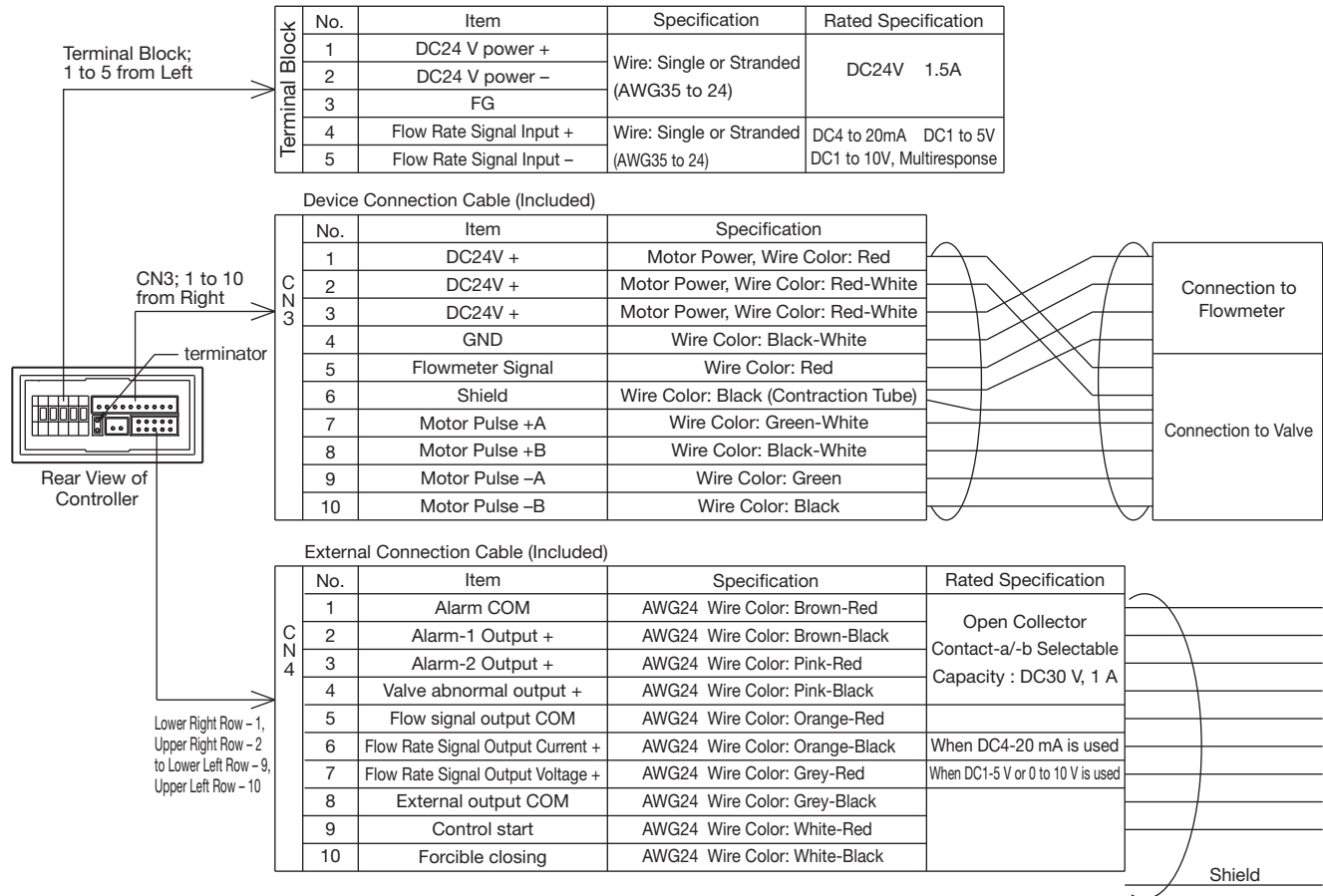

* Specification is subject to change without notice.

TIV TOKYO KEISO CO., LTD.

Head Office : Shiba Toho Building, 1-7-24 Shibakoen, Minato-ku, Tokyo 105-8558
 Tel : +81-3-3431-1625 (KEY) ; Fax : +81-3-3433-4922
 e-mail : overseas.sales@tokyokeiso.co.jp ; URL : https://www.tokyokeiso.co.jp