



TECHNICAL GUIDANCE

METAL TUBE VARIABLE AREA FLOWMETER

AM7000 Series

GENERAL

The metal tube variable area flowmeter AM7000 Series has been developed from AM-1000 Series which were based on the long time experience of TOKYO KEISO in the field of flow measurement. In addition to highly reliable local indicators, a variety of outputs are equipped to meet the requirements. Standard metallic materials and full line-up of lined materials cover almost all fluids even they are very corrosive. AM7000 covers liquids, gases and steam measurement applications in various industrial fields.



FEATURES

FULL LINE-UP TO MEET ALL POSSIBLE REQUIREMENTS !!

All the necessary functions required for variable area flowmeter, i.e. local indication, electric transmitters, local flow integration HART communication, integrator with scaled pulse output and alarm are now available from one line.

COMPACT DESIGN

Smaller and lighter...To suit modern needs.

WIDE PRESSURE RANGE

150 lbs and 300 lbs rating are available as standard and higher pressure versions are also available as option.

WIDE RANGE OF MATERIAL SELECTION

All possible metallic materials and a wide variety of lining materials are available even for corrosive fluids.

HART COMMUNICATION PROTOCOL CAN BE CONNECTED.

CORRESPONDING TO EXPLOSION-PROOF CONSTRUCTION

Certification: TIIS, KOSHA, NEPSI, ATEX & IECEx

DUST TIGHT AND WATER IMMERSION PROOF

IP67

MODEL CODE

Basic model		Material/Connection code		Function 1 code	Function 2 code etc.	Basic model and Function 1 code may be indicated in the quotation.	
AM7	<input type="checkbox"/>	<input type="checkbox"/>	<input type="checkbox"/>	<input type="checkbox"/>	<input type="checkbox"/>	Specifications	
Flow direction	1					Bottom→Top	
	2					Bottom→Top side	
	3					Bottom side→Top side	
	6					Left→Right	
	7					Right→Left, Front→Rear, Rear→Front	
Function of indicator	L					Local indication	
	E					Electric transmitter	
	H					Electric transmitter with HART communication	
	T					Local integration	
	R					Reed switch	
	N					Proximity switch	
Explosionproof	W					Dust tight, water immersion proof, non-explosionproof	
	E					Flameproof version	
	S					Intrinsic safety version	
Wetted material	0 1					Material of main body :C.S./SUS304	
	0 2					Material of float :SUS304	
	0 3					SUS304	
	0 4					SUS316	
	R 1					SUS316L	
	R 2					Rubber lining	
	F 1					Rubber lining	
	P 1					Fluorocarbon resin lining	
	G 1					Fluorocarbon resin lining	
	G 2					PVC lining	
Z					Glass lining		
Rating	J 1					JIS 10K	
	J 4					JIS 20K	
	J 5					JIS 30K	
	A 2					ANSI CLASS 150	
	A 5					ANSI CLASS 300	
	A 6					ANSI CLASS 400	
	P 2					JPI CLASS 150	
	P 5					JPI CLASS 300	
	P 6					JPI CLASS 400	
	I D					IDF Clamp	
Connection	Z					Others	
	R					R.F.	
	F					F.F.	
	C					Clamp-on type	
	J					Ring joint	
Connection size	- 1					15 mm (1/2")	
	- 2					20 mm (3/4")	
	- 3					25 mm (1")	
	- 4					40 mm (1-1/2")	
	- 5					50 mm (2")	
	- 6					65 mm (2-1/2")	
	- 8					80 mm (3")	
	- A					100 mm (4")	
	- B					125 mm (5")	
	- C					150 mm (6")	
Additional function 1	- D					200 mm (8")	
	- Z					Others	
	/ L					Long body	
	/ F					Radiating fin	
	/ J					Semi-jacket	
	/ J					Full-jacket	
	/ J					Upper jacket	
	/ J					Vacuum jacket	
	/ D					Liquid damper	
	/ D					Gas damper	
Additional function 2	/ S					Sanitary (#320 to #400)	
	/ S					Slurry	
	/ E					E 1 Electric transmitter	
	/ E					E 2 Electric transmitter (intrinsically safe)	
	/ H					H 1 Electric transmitter with HART communication	
	/ H					H 2 Electric transmitter with HART communication (intrinsically safe)	
	/ T					T 1 Local integrator+Electric transmitter+integrator with scaled pulse (or alarm)	
	/ T					T H Local indication+Analog current output with HARTcommunication+Integrated pulse (or alarm)	
	/ R					R <input type="checkbox"/> Reed switch <input type="checkbox"/> shows conditions of switch action.	
	/ N					N <input type="checkbox"/> Proximity switch A : High alarm CLOSE(ON), B : High alarm OPEN(OFF), C : Low alarm CLOSE(ON), D : Low alarm OPEN(OFF)	
Output function	/ M					M <input type="checkbox"/> Microswitch Ex. Reed switch/2-point alarm (High alarm CLOSE×1, OPEN×1): /RAB	
	/ J					J E TIIS Flameproof version	
	/ K					K E KOSHA Flameproof version	
	/ C					C E NEPSI Flameproof version	
	/ E					E E ATEX Flameproof version	
	/ E					E E IECEx Flameproof version(Specify separately.)	
	/ J					J I TIIS Intrinsic safety version	
	/ K					K I KOSHA Intrinsic safety version	
	/ C					C I NEPSI Intrinsic safety version	
	/ E					E I ATEX Intrinsic safety version	
Explosionproof type	/ M					M 2 M20×1.5(F)	
	/ G					G 1 G1/2(F)	
	/ G					G 2 G3/4(F)	
	/ N					N 1 NPT1/2(F)	
	/ N					N 2 NPT3/4(F)	
Cable entry	/ O					O L Oil-free treatment	
	/ W					W L Water-free treatment	
	/ A					A P Pickling treatment	
	/ P					P S Special painting color	
	/ E					E P Electrolytic polishing	
Option	/ L					L T Airtight test	
	/ P					P C Waterproof connector	
	/ F					F G Flameproof cable gland	
	/ A					A C Other accessories	
	/ W					W S Double scale, output for main scale	
Special spec.	/ W					W E Double scale, output for main and sub scales	
	/ Z					Z Z Contact us for details.	

STANDARD SPECIFICATION

● **FUNCTIONS**

AM7□□□	AM7□□□/E□	AM7□□□/H□	AM7□□□/T□	AM7□□□ /R□, /N□, /M□
Local indication	Local indication Electric transmitter	Local indication Electric transmitter HART communication	Local indication Electric transmitter Local integration Pulse output Alarm output	Local indication Alarm output

● **METER SIZE** 15 to 150 (Please refer to M Series for more than 200)

● **MATERIAL** Carbon steel, SUS304, SUS316, SUS316L,
Rubber lining, Fluorocarbon resin lining, PVC lining and Glass lining
On request Other metallic material

● **PRESSURE RATING**

150lbs (10K) class, 300lbs (20K) class

On request Consult factory for higher pressure.

* Only 150lbs (10K) class is available for full jacketed flow meters (AM7□□□/JF) and lining material flow meters.

● **FLUID PRESSURE**

Fluid Temp. (°C)	General purpose 150lbs (10K) class			Medium purpose 300lbs (20K) class					Lining type
	up to 120	up to 220	up to 300	up to 120	up to 220	up to 300	up to 350	up to 400	Refer to Page 4
Max. fluid press. (MPa)	1.4	1.2	1.0	3.4	3.1	2.9	2.6	2.3	1.0

Consult factory for the specifications of higher pressure model.

● **CONNECTION** Flange connection [On request Screw connection (Consult factory)]

General purpose	JIS 10K FF	ANSI, JPI, DIN Other type are available
Medium purpose	JIS 20K RF	
Higher purpose	Consult factory	

Only RF (Raised faced) flange is available for glass, PVC and fluorocarbon resin lined flow meters.

Only FF (Flat faced) flange is available for rubber lined flow meters.

● FLUID TEMPERATURE

(a) Metallic material

Type	AM71□□	AM72□□ AM73□□	AM7□□□/DU	AM72□□/FB AM73□□/FB (Fluid : Gases)	AM72□□/FB AM73□□/FB (Fluid : Liquids)
Operating temperature range of fluid	-20 to 200°C *1 *2	0 to 149°C *3	0 to 149°C	to 0°C 150 to 400°C *4	150 to 400°C *2 *4

Notes : The flowmeters out of the above temperature range may be available on your request. Consult TOKYO KEISO Co., Ltd. for details.

- *1 Available up to 250°C as an option.
- *2 A very low temperature version is also available as an option.
- *3 Select AM72□□/FB or AM73□□/FB when temperature of gas service is lower than 0°C , or 150°C or higher.
Select AM72□□ /FB or AM73□□/FB when temperature of liquid service is 150°C or higher.
Available as low as -50°C as an option for lower than 0°C liquid service.
- *4 The Max. fluid temperature of ordinary type 150 lbs class is 300°C.

(b) Lining material

Rubber lining	Fluorocarbon resin lining	PVC lining	Glass lining
-10 to 80°C	-10 to 80°C	0 to 60°C	-10 to 110°C *

* Max. 80°C for fluorocarbon resin float

- INDICATION ACCURACY ±1.5 F.S. (On request ±1.0 F.S., Consult factory)
* ±2% F.S. for resin material float version

- STANDARD SCALE LENGTH 70mm

- RANGEABILITY 10:1 (10:2 for the slurry type)

- INDICATOR CONSTRUCTION Dust tight and water immersion proof IP67

- PAINTING COLOR

PAINTING	COLOR	
Measuring tube (Carbon steel), Indicator body	Jade green	(Munsell 7.5BG4/1.5)
Indicator cover · Transmitter	Light gray	(Munsell N7.5)
Cooling fin	Metallic silver	—

AM7□□□ (LOCAL INDICATION)

- AMBIENT TEMPERATURE -30 to 80°C

- Dimension of indicator

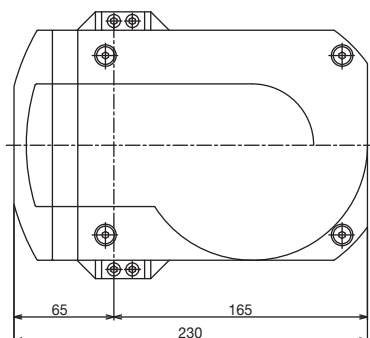
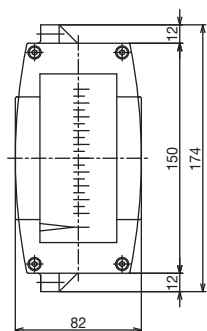

Approx. mass: 2.5kg

AM7□□□ /E□ (LOCAL INDICATOR WITH ELECTRIC TRANSMITTER)

AM7□□□ /E□ indicates flow rate by pointer and scale plate, and outputs electric (4 to 20mA DC) signal which is proportional to flow rate. In addition to the dust tight and water immersion proof type, the intrinsically safe (dust explosion-proof) and flame proof versions are available.

● SPECIFICATION OF TRANSMITTER

Power supply voltage	: 10 to 30V DC (Voltage between transmitter terminals)
	(For Intrinsically safe version : 10 to 28V DC/For TIIS Flameproof version: 12 to 30 VDC)
Current output	: 4 to 20mA DC
	(Effective output range : 4.0 to 21.6mA At abnormal condition, however, 22.8mA or 3.75mA as an option can be output.)
Allowable load resistance	: Less than 830Ω (580Ω or less / 24V DC)
	Determine the allowable load resistance for each supply voltage using following formula.
	Allowable load resistance \leq (Power supply voltage [V] - 10) / 0.024 [Ω]
	The allowable load resistance includes the one of circuit wiring.
Output accuracy	: $\pm 1.0\%$ F.S. (Against flow calibration)
Low cut off	: 0 to 20%F.S. (default 7%F.S.)
Damping	: 0 to 20s (default 1s)
Cable entry	: Weather proof 2-M20×1.5, 2-G1/2, 2-NPT1/2, Weather proof connector
	: Intrinsically safe & Flame proof 2-M20×1.5, 2-G1/2, 2-NPT1/2, Packing type cable gland
	Note : The packing type cable gland model SXC -16BY made by Shimada Electric Co. shall be used for the TIIS flame proof construction. The cable entry for the indicator is G1/2 only.
Construction	: Dust tight and water immersion proof IP67
	: Intrinsically safe (dust explosion-proof) Ex ia IIC T1 to T6 AM7□□□/E2/□ The temperature class of TIIS certified products is T6. II 2 D Ex ia IIIC T135°C Db (For ATEX certified products)
	: Flame proof Ex d IIC T1 to T6 AM7□□□/E1/□E The temperature class of TIIS certified products is T4.
Ambient temp.	: Dust tight and water immersion proof -20 to 70°C
	: Intrinsically safe -20 to 60°C
	: Flame proof -20 to 55°C (For TIIS certified products)
	-20 to 60°C (For other certified products)
Insulation resistance	: 20 MΩ or more / 500V DC (between batch of power supply terminal and indicator case)
Withstand voltage	: 500V AC/1min (between batch of power supply terminal and indicator case)

● DIMENSION OF INDICATOR / TRANSMITTER

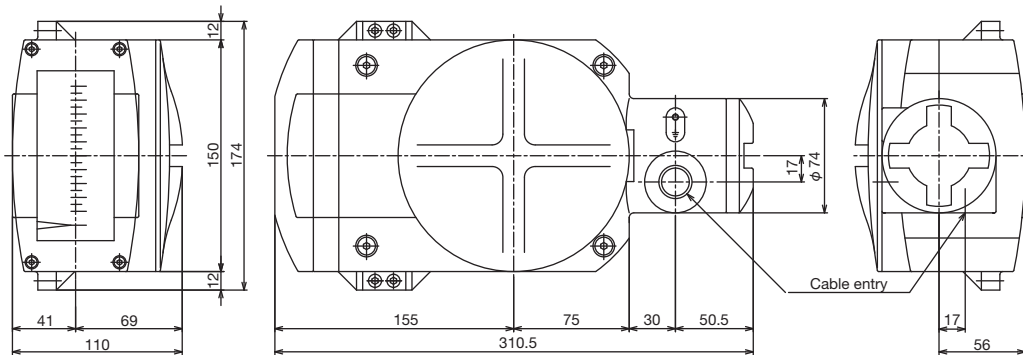

Approx. mass: 3.7kg

● TERMINAL AND WIRING

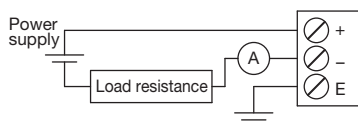

AM7□□□/H□ (LOCAL INDICATOR WITH ELECTRIC TRANSMITTER & HART COMMUNICATION)

AM7□□□/H□ indicates flow rate by pointer and scale plate, and outputs electric (4 to 20mA DC) signal equipped with HART Communication complying with Multi-drop. In addition to the dust tight and water immersion proof type, the intrinsically safe (dust explosion-proof) and flame proof versions are available.

● SPECIFICATION OF TRANSMITTER

Power supply voltage	: 10 to 30V DC (Voltage between transmitter terminals) (For Intrinsically safe version: 10 to 28V DC/For TIIS Flameproof version: 12 to 30 VDC)
Current output	: 4 to 20mA DC (Effective output range : 4.0 to 21.6mA At abnormal condition, however, 22.8mA or 3.75mA as an option can be output.)
Allowable load resistance	: 230 to 830Ω (Not less than 230Ω load resistance is needed for “with HART communication.”) Determine the allowable load resistance for each supply voltage using following formula. Allowable load resistance ≅ (Power supply voltage [V] -10) / 0.024 [Ω] The allowable load resistance includes the one of circuit wiring.
Output accuracy	: ±1.0%F.S. (Against flow calibration)
Low cut off	: 0 to 20%F.S. (default 7% F.S.)
Damping	: 0 to 20s (default 1s)
Cable entry	: Weather proof 2-M20×1.5, 2-G1/2, 2-NPT1/2, Weather proof connector : Intrinsically safe & Flame proof 2-M20×1.5, 2-G1/2, 2-NPT1/2, Packing type cable gland Note : The packing type cable gland model SXC -16BY made by Shimada Electric Co. shall be used for the TIIS flame proof construction. The cable entry for the indicator is G1/2 only.
Construction	: Dust tight and water immersion proof IP67 : Intrinsically safe (dust explosion-proof) Ex ia IIC T1 to T6 AM7□□□/H2/□ The temperature class of TIIS certified products is T6. II 2 D Ex ia IIIC T135°C Db (For ATEX certified products) : Flame proof Ex d IIT1 to T6 AM7□□□/H1/□E The temperature class of TIIS certified products is T4.
Ambient temp.	: Dust tight and water immersion proof -20 to 70°C : Intrinsically safe -20 to 60°C : Flame proof -20 to 55°C (For TIIS certified products) -20 to 60°C (For other certified products)
Insulation resistance	: 20 MΩ or more/500V DC (between batch of power supply terminal and indicator case)
Withstand voltage	: 500V AC/1min (between batch of power supply terminal and indicator case)

● DIMENSION OF INDICATOR / TRANSMITTER

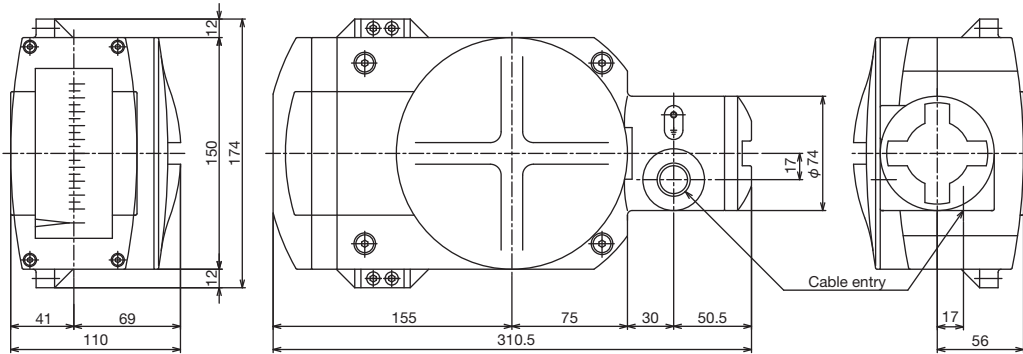

Approx. mass: 3.7kg

● TERMINAL AND WIRING

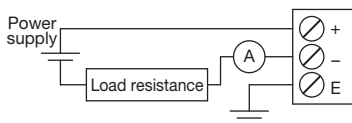

AM7□□□/□ (LOCAL INDICATOR WITH LOCAL INTEGRATION, INTEGRATION PULSE, ELECTRIC TRANSMISSION AND HART COMMUNICATION)

With local flow rate indication, AM7□□□/□ has the functions of local flow integration, integration pulse output, 4 to 20mA electric output and Hart communication. This series serves the custody of flow. The additional magnetic sensing switches to conventional push buttons are available for customers' convenience. In addition to the dust tight and water immersion proof type, the flame proof version is available.

● **SPECIFICATION OF TRANSMITTER**

- Integration : 6 digit red LCD (With 8 digit scaling and reset function)
- Count rate : Less than 10Hz (Less than 36000 c/h)
- Pulse or Alarm output : NPN Open collector 2 point select output (Pulse width : 30ms, 50ms, 100ms, 200ms, 500ms)
: 1 point alarm + pulse output, or 2 points alarm output (Alarms are selectable from the flow rate or the integrated flow alarm.)
: Max. voltage 30V DC, max. current 50mA
(The power supply circuit and the output circuit are insulated.)
Reverse-connected protection, Residual voltage when turning it on more less 1.2V (10mA)
- Integration accuracy : ±1.0%F.S. (Against flow calibration)
- Power supply : 16 to 30V DC (Voltage between transmitter terminals)
- Current consumption : Less than 60mA
- Current output : 4 to 20mA DC
(Effective output range : 4.0 to 21.6mA At abnormal condition, however, 22.8mA or 3.75mA as an option can be output.)
- Allowable load resistance : Less than 830Ω (In case of HART communication version : 230 to 830Ω)
Determine the allowable load resistance for each supply voltage using following formula.
Allowable load resistance ≤ (Power supply voltage [V] - 10) / 0.024 [Ω]
The allowable load resistance includes the one of circuit wiring.
- Output accuracy : ±1.0%F.S.(Against flow calibration)
- Low cut off : 0 to 20%F.S. (default 7%F.S.)
- Damping : 0 to 20s (default 1s)
- Cable entry : 2-G3/4, 2-NPT3/4, Packing type cable gland
Note : The packing type cable gland model SXC -22BY made by Shimada Electric Co. shall be used for the TIIS flame proof construction. The cable entry for the indicator is G3/4 only.
- Construction : Dust tight and water immersion proof IP67
: Flame proof Ex d IIC T1 to T6 AM7□□□□/□□□□
The temperature class of TIIS certified products is T4.
- Ambient temp. : Dust tight and water immersion proof -20 to 70°C
: Flame proof -20 to 55°C (For TIIS Certified products)
-20 to 60°C (For other Certified products)
- Insulation resistance : 20 MΩ or more/500V DC
(between batch of power supply terminal and indicator case)
- Withstand voltage : 500V AC/1min
(between batch of power supply terminal and indicator case)



● **DIMENSION OF INDICATOR/TRANSMITTER**

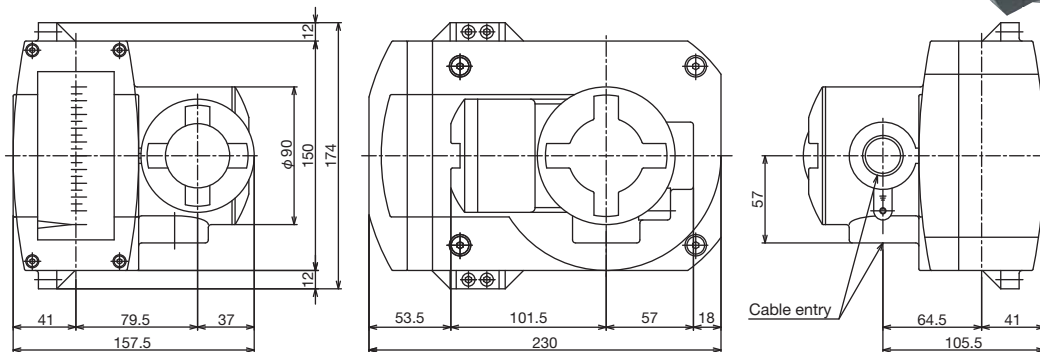

Approx. mass: 3.8kg

● **TERMINAL AND WIRING**

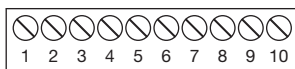

Terminal No.	1	2	3	4	5	6	7	8	9	10
Terminal wiring	DO1+	DO1-	DO2+	DO2-	/	R+	R-	PS+	PS-	FG

(Attention) DO: Contact output terminals, R: 4-20mA analog output terminals, PS: Power supply, FG: Grounding

AM7□□□/R□ (LOCAL INDICATOR WITH REED SWITCH TYPE ALARM)

AM7□□□/R□ indicates flow rate by pointer and outputs SPST contact at set point for flow alarm.
 In addition to the dust tight and water immersion proof type, the intrinsically safe (dust explosion-proof) version is available.

● SPECIFICATION OF TRANSMITTER

- Alarm point : 2 points (1 point high alarm, 1 point low alarm or 2 points high and low alarm)
- Switch : Self-holding reed switch (a or b contact)
- Rating : Reed switch (SPST) 10VA AC, 10W DC as resistance load
 Max. 125V AC/0.5A, Max. 100V DC/0.5A
- Setting accuracy : ±1.5% F.S. (Against flow calibration)
 Note: While switch is on, and if any other flow rate than the alarm setting value is indicated, it may result in causing wrong accuracy.
- Reset span : Less than 10% F.S. (Against flow calibration)
- Cable entry : G1/2 or NPT1/2 or others
- Enclosure : Dust tight and water immersion proof IP67
 : Intrinsically safe Ex ia IIC T1...T6
 (dust explosion-proof)
 (TIIS certified products are subject to the safety barrier. See Page 12 for details.)
 II 2 D Ex ia IIIC T135°C Db (For ATEX certified products)
- Ambient temp. : -10 to 60°C
- Insulation resistance : 100 MΩ or more/500V DC (between batch of power supply terminal and indicator case)
- Withstand voltage : 1500V AC/1min (between batch of power supply terminal and indicator case)

● DIMENSION OF INDICATOR / TRANSMITTER

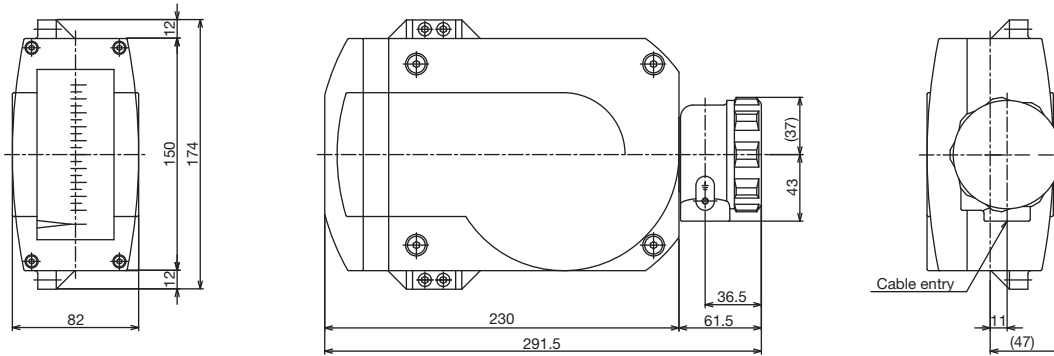

Approx. mass: 2.8kg

● TERMINAL AND WIRING

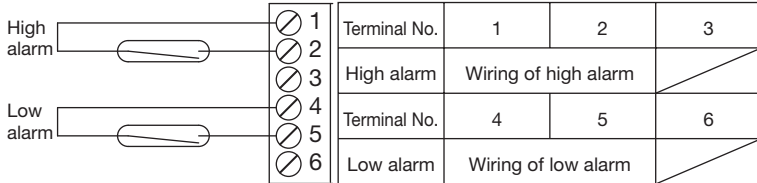

Note : Terminal No.4 and 5 are not used for 1 point high alarm. Likewise, terminal No. 1 and 2 are not used for 1 point low alarm.



AM7□□□/N□ (LOCAL INDICATOR WITH PROXIMITY SWITCH TYPE ALARM)

With local flow rate indication, AM7□□□/N□ has a proximity switch which outputs alarm signals complying with NAMUR standard. In addition to the dust tight and water immersion proof type, the intrinsically safe (dust explosion-proof) version is available.

● SPECIFICATION OF TRANSMITTER

- Alarm point : 2 points (1 point high alarm, 1 point low alarm or 2 points high and low alarm)
- Switch : Proximity switch
- Power supply voltage : 8V DC
- Operating current : Proximity switch complying with NAMUR, ON : 1mA or less, OFF : 3mA or more
- Setting accuracy : ±1.5% F.S. (Against flow calibration)
- Reset span : Less than 1.5% F.S. (Against flow calibration)
- Cable entry : G1/2 or NPT1/2 or others
- Enclosure : Dust tight and water immersion proof IP67
 : Intrinsically safe Ex ia IIC T1...T6
 (dust explosion-proof) (The temperature class of TIIS certified products is T5. See Page 12 for details.)
 II 2 D Ex ia IIIC T135°C Db (For ATEX certified products)
- Ambient temp. : Dust tight and water immersion proof -25 to 80°C
 : Intrinsically safe -20 to 60°C TIIS certified transmitter
 -20 to 50°C Other certified transmitters
 (Ambient temperatures above are subject to the safety barrier.)
- Insulation resistance : 100 MΩ or more/500V DC (between batch of power supply terminal and indicator case)
- Withstand voltage : 500V DC/1min (between batch of power supply terminal and indicator case)

● DIMENSION OF INDICATOR / TRANSMITTER

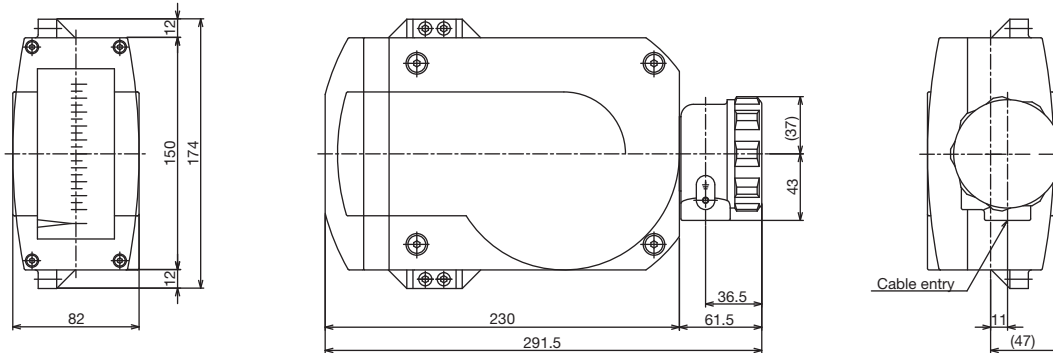

Approx. mass: 2.8kg

● TERMINAL AND WIRING

1	Terminal No.	1	2	3
2	High alarm	+	-	/
3	Terminal No.	4	5	6
4	Low alarm	+	-	/
5				
6				

Note : Terminal No.4 and 5 are not used for 1 point high alarm. Likewise, terminal No. 1 and 2 are not used for 1 point low alarm.



AM7□□□/□ (LOCAL INDICATOR WITH MICRO SWITCH TYPE ALARM)

With local flow rate indication, AM7□□□/□ has a micro switch which outputs SPDT alarm signals.
 In addition to the dust tight and water immersion proof type, the intrinsically safe (dust explosion-proof) version is available.

● SPECIFICATION OF TRANSMITTER

- Alarm point : 2 points (1 point high alarm, 1 point low alarm or 2 points high and low alarm)
- Switch : Micro switch (c contact)
- Rating : 250V AC/5A as resistance load
- Setting accuracy : $\pm 1.5\%$ F.S. (Against flow calibration)
 - Note: While switch is on, and if any other flow rate than the alarm setting value is indicated, it may result in causing wrong accuracy.
- Reset span : Less than 20% F.S. , less than 30% F.S. when 2 alarm contacts work simultaneously. (Against flow calibration)
- Cable entry : G1/2 or NPT1/2 or others
- Enclosure : Dust tight and water immersion proof IP67
 - : Intrinsically safe Ex ia IIC T1...T6 (dust explosion-proof) (TIIS certified products are subject to the safety barrier. See Page 12 for details.)
 - II 2 D Ex ia IIIC T135°C Db (For ATEX certified products)
- Ambient temp. : Dust tight and water immersion proof -25 to 80°C
 - : Intrinsically safe -20 to 60°C
- Insulation resistance : 100 MΩ or more/500V DC (between batch of power supply terminal and indicator case)
- Withstand voltage : 1500V AC/1min (between batch of power supply terminal and indicator case)

● DIMENSION OF INDICATOR / TRANSMITTER

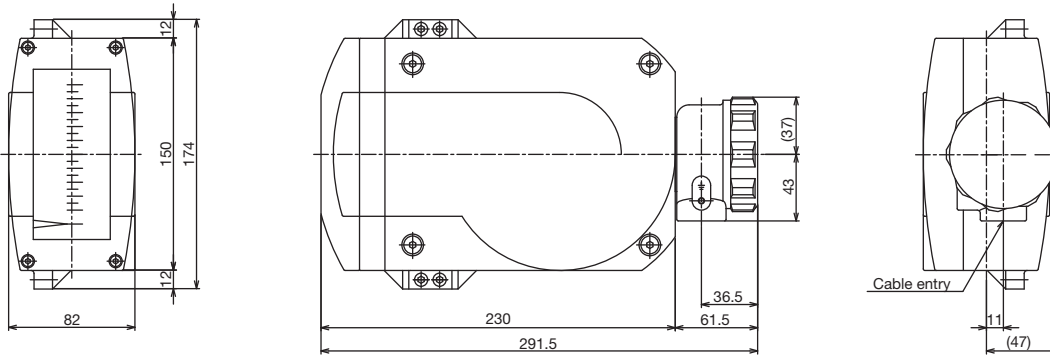

Approx. mass: 2.8kg

● TERMINAL AND WIRING

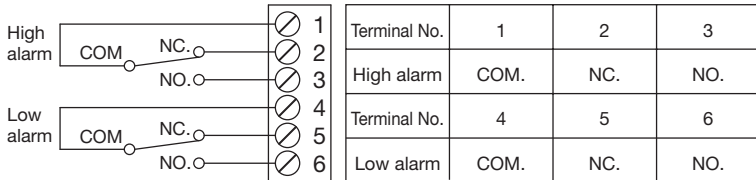

Note : Terminal No.4, 5, 6 are not used for 1 point high alarm. Likewise, terminal No. 1,2,3 are not used for 1 point low alarm.



AM7□□□/□□/□E (FLAME PROOF)

AM7□□□/□□/□E outputs an alarm signal by SPDT contacts by adding a micro switch to the local flow rate indicator.

● SPECIFICATION OF TRANSMITTER

Alarm point : 2 points (1 point high alarm, 1 point low alarm or 2 points high and low alarm)

Switch : Micro switch (c contact)

Rating : 125V AC/1A or 30V DC/1A

Setting accuracy : ±1.5% F.S. (Against flow calibration)

Note: While switch is on, and if any other flow rate than the alarm setting value is indicated, it may result in causing wrong accuracy.

Reset span : Less than 15% F.S. (Against flow calibration), less than 20% F.S. when 2 alarm contacts work simultaneously.

Cable entry : G1/2 or NPT1/2 or others

Enclosure : Dust tight and water immersion proof IP67

: Flameproof Ex d IIC T1 to T6

(The temperature class of TIIS certified products is T4. See Page 12 for details.)

Ambient temp. : Dust tight and water immersion proof -25 to 80°C

: Flameproof -20 to 55°C TIIS-certified transmitter

-20 to 60°C Other certified transmitters

Insulation resistance : 100 MΩ or more/500V DC (between batch of power supply terminal and indicator case)

Withstand voltage : 1500V AC/1min (between batch of power supply terminal and indicator case)

● DIMENSION OF INDICATOR / TRANSMITTER

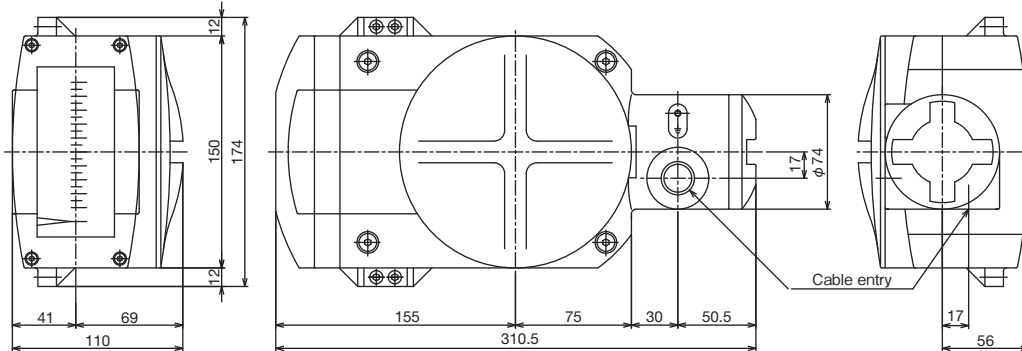

Approx. mass: 3.7kg

● TERMINAL AND WIRING

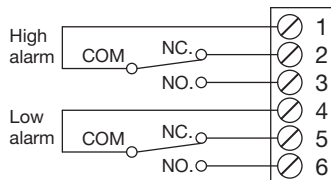

Terminal No.	1	2	3
High alarm	COM.	NC.	NO.
Terminal No.	4	5	6
Low alarm	COM.	NC.	NO.

Note : Terminal No.4, 5, 6 are not used for 1 point high alarm. Likewise, terminal No. 1,2,3 are not used for 1 point low alarm.



AM7□□□/□□/□E (FLAMEPROOF VERSION)

The flameproof model with electric or alarm output (microswitch) as an additionally specified feature, is available complying with the standard.

EX type	Class	Functions			
		Current transmission	Current Transmission HART communication	Local integration	Alarm output microswitch
TIIS	Ex d IIC T4	○	○	○	○
KOSHA	Ex d IIC T6 to T1	○	○	○	○
NEPSI	Ex d IIC T1 to T6 Gb	○	○	○	○
ATEX	II2G Ex d IIC T6... T1 Gb	○	○	○	○
IECEX	Ex d IIC T6... T1 Gb	○	○	○	○

NOTE) Be sure to use the cable gland shown in the figure below for the TIIS flameproof version (current transmission, current transmission HART communication, or local integration or alarm output).
 ※Cable diameters applicable to cable glands included in the product.

For the current transmission, current transmission HART communication.

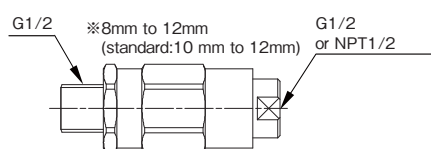

SXC-16BY By Simada Electric Co.

For the site integration

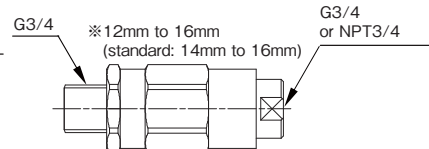

SXC-22 By Simada Electric Co.

For the alarm output

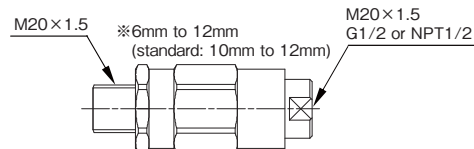

EXPC-16B by Simada Electric Co.

AM7□□□/□□/□I [INTRINSICALLY SAFE VERSION (dust explosion-proof)]

Intrinsically safe modes complying with the standard are available depending on additionally specified features of the current transmission, or alarm output.

EX type	Class	Functions			
		Current transmission	Current Transmission HART communication	Local integration	Alarm output
TIIS	Ex ia IIC T6	○	○	—	(Note1)
	Ex ia IIC T5	—	—	—	(Note1)
KOSHA	Ex ia IIC T1 to T6	○	○	—	○
NEPSI	Ex ia IIC T1 to T6 Gb	○	○	—	○
ATEX	II 2 G Ex ia IIIC T1... T6 Gb II 2 D Ex ia IIIC T135°C Db	○	○	—	○

Note 1: The read switch type (AM7□□□/□R□) and the micro switch type (AM7□□□/□M□) are available only when the intrinsically safe relay barrier is used.
 The temperature class of the TIIS intrinsically safe proximity switch type (AM7□□□/□N□) is T5. Consult us for details.

● INTRINSICALLY SAFE SPECIFICATION OF CURRENT TRANSMISSION

	Current transmission (AM7□□□/□E2/□I)
Max.voltage for intrinsically safe circuit	28V DC
Max.current for intrinsically safe circuit	93mA
Max.power consumption for intrinsically safe circuit	650mW
Capacitance inside intrinsically safe circuit	5nF
Inductance inside intrinsically safe circuit	0.2mH

● INTRINSICALLY SAFE SPECIFICATION OF ALARM OUTPUT

	Read switch AM7□□□/□R□/□I	Proximity switch AM7□□□/□N□/□I		Micro switch AM7□□□/□M□/□I
		TIIS intrinsically safe product	Other products	
Max.voltage for intrinsically safe circuit	30V DC	10.5V DC	16V DC	30V DC
Max.current for intrinsically safe circuit	500mA	13mA	25mA	500mA
Max.power consumption for intrinsically safe circuit	—	34mW	64mW	—
Capacitance inside intrinsically safe circuit	—	150nF	150nF	—
Inductance inside intrinsically safe circuit	—	150μH	150μH	—
Recommended relay barrier	EB3C (IDEC)	KFD2-SR2-Ex1.W (P&F) (Note 2)		EB3C (IDEC)

Note: 2 The TIIS intrinsically safe proximity switch has been certified in combination with barriers made by PEPPERL+FUCHS. Be sure to use intrinsically safe proximity switches with the barriers shown below. For other proximity switches, use the explosion-proof barriers conforming to the rated values above.

TIIS intrinsically safe barrier

For 1ch:KFD2-SR2-Ex1.W

For 2ch:KFD2-SR2-Ex2.W

ADDITIONAL FUNCTION

● Cooling fin

(Model AM7□□□/FB)

A cooling fin is to be provided between tube part and indicator housing to release fluid heat in case fluid temperature is more than 150°C. Cooling fin is available for models AM72□□ (Bottom-Top side), AM73□□ (Bottom side-Top side), AM76□□ (Left- Right) and AM77□□ (Right-Left).

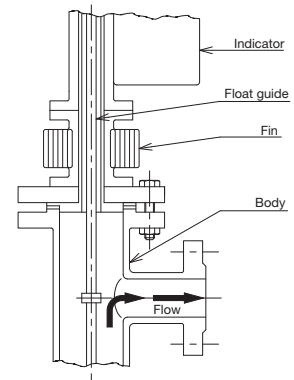

● Jacket

(Model AM7□□□/JS, Semi-jacket, AM7□□□/JF, Full-jacket)

Heating jacket is available for the application of high viscosity and/or sticky fluids. Semi-jacket covers tube part only and full-jacket covers flanges as well. Steam inlet/outlet is screw connection (Rc or NPT). Heating jacket is available for AM71□□ (Bottom-Top) and AM72□□ (Bottom-Top side). Only 150 lbs rating is available for full-jacketed flowmeters (AM□□□/JF).

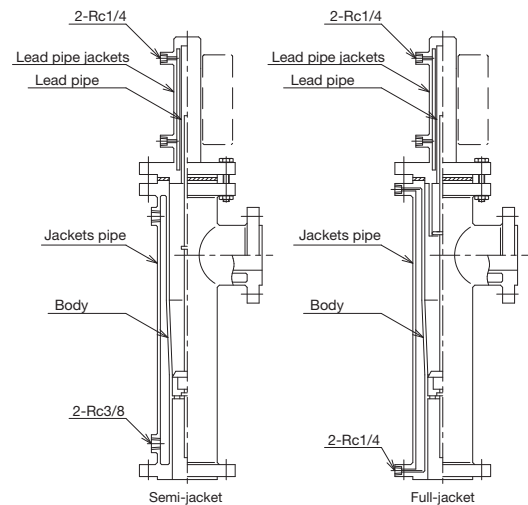

● Liquid damper

(Model AM7□□□/DL)

A damper is to be provided for steam and gas applications to prevent vibration of float. A damper pot is provided at the bottom of tube part in which damper liquid (silicon or diflon oil) is contained. The friction between damper liquid and damper makes the float movement smooth for stable indication and durability of moving part. Damper is also recommended for liquid application with heavy pulsation. Available types are AM73□□ (Bottom side-Top side), AM76□□ (Left- Right) and AM77□□ (Right-Left).

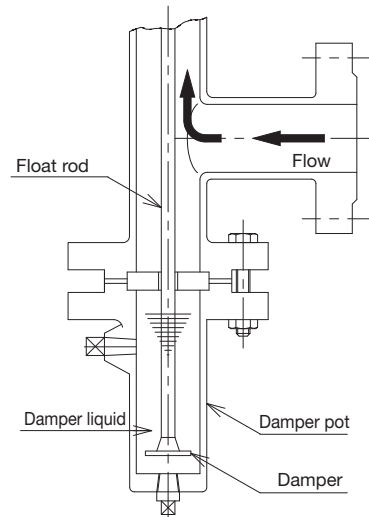

● Gas damper

(Model AM7□□□/DU)

Gas damper is available for gas measurement application which does not require damper liquids. (Gas dampers are available for metallic flowmeters only.)

Mechanical damper is integrated at the part of float guide which consists of piston and cylinder. As it is not required to install liquid damper at the bottom of flowmeters, it contributes to increase the flexibility of piping design. Also it is not required to fill damper liquid that saves maintenance labour works.

Gas damper is applicable for gas measurement applications and not suitable for liquids and steam. Also chlorine gas (easy to form chemical compound) and gas containing rust, trash and oil may hinder the function of piston part. Consult factory for details. Available size is 20mm to 100mm (Not available for 15mm) and only for metallic material (Not for lined material).

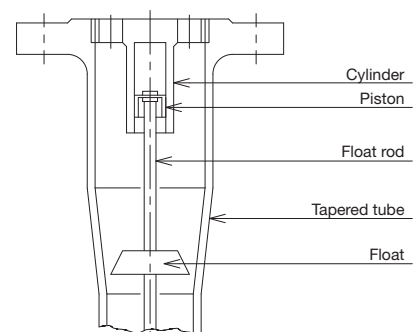

● **Slurry**
 (Model AM7□□□/SL)

The structure of the float and float part allows solids to pass easily. Accordingly, this model is suitable for measuring liquids containing fibers, granules, etc. In addition to the standard stainless steel, PVC lining is available, which is suitable for plating drainage and other highly corrosive liquids.

Allowable size of solid matter in measuring fluid (mm)

Meter size	15	20	25	40	50	65	80	100	125	150
Size ϕ	0.01	0.15	0.2	0.3	0.5	0.8	1.0	1.0	1.0	1.0

● **Sanitary**
 (Model AM71□□/SR)

This model is designed and manufactured for sanitary processes. It can be fitted onto process lines through IDF clamps (ISO standard). All wetted parts are buff polished (#320 to #400). It can be easily disassembled and assembled for cleaning. The electrolytic polishing is also available as an option. See the Technical Guidance TG-F1152 of AM7000/SR series.

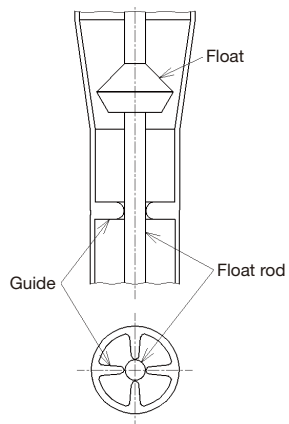

DIMENSIONS, MATERIAL, PRESSURE LOSS, FLOW RATE TABLE

[METALLIC MATERIAL]

- AM71□□ (Flow direction : Bottom—Top)
 - AM71□□ (Flow direction : Bottom—Top, Large flow type)
 - AM71□□/LB (Flow direction : Bottom—Top, Long body design)
- For liquid

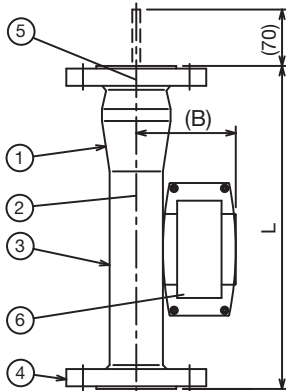

*1 Float rod comes out 70mm during operation in meter size 20mm to 150mm. The straight length of downstream pipe with the same size as the flowmeter must be more than 70 mm for a free movement of the float rod. For AM71□□ (Flow direction: Bottom- Top, Large flow type), the float rod does not come out. The material of the tapered tube is SCS16. In case of AM71□□/LB (Bottom-Top, Long body design) this coming out is avoided by extending the tube length. The extension length of body (L dimension) is 130mm for 10K (150lbs) version. Consult factory for length of 20K (300lbs) version.

■ Table 1

Figures in () are those of 20K class.

Meter size	Q water (m ³ /h)	Pressure loss (kPa)	10K, Class 150			20K, Class 300		
			L (mm) *1	(B) (mm)	Mass (approx.)	L (mm)	(B) (mm)	Mass (approx.)
15	0.1~0.75 (0.7)	6.5	350	94	5	350	94	5
20	1.5 (1.5)	6.0	350	94	5	400	94	6
25	4.06 (3.8)	7.3	350	97	6	400	97	7
40	7.15 (7.15)	9.0	400	104	8	400	104	9
50	15.1 (15.1)	6.3	400	110	10	450	110	12
65	27.5 (26.5)	7.8	450	118	13	500	118	18
80	40.5 (39.5)	9.1	450	125	15	500	125	20
100	71.9 (67.5)	12.0	450	137	20	500	137	28
100 (Large flow type)	100 (100)	20.0						
125	110 (—)	14.0	500	150	32	—	—	—
125 (Large flow type)	150 (—)	22.0						
150	150 (—)	18.0	500	163	50	—	—	—
150 (Large flow type)	200 (—)	28.0						

Note: The mass shown in the table is for the local indicator, and it is also same for the mass in the subsequent tables. In case of "with transmission function," refer to the outside dimension for each model.

■ Table 2

No	Description	Class 1	Class 2	Class 3	Class 4
1	Tapered tube	SUS304	SUS304	SUS316	SUS316L
2	Float ass'y	SUS304	SUS304	SUS316	SUS316L
3	Lower body	SUS304	SUS304	SUS316	SUS316L
4	Flange	SS400	SUS304	SUS316	SUS316L
5	Float guide	SUS304	SUS304	SUS316	SUS316L
6	Indicator	ADC12	ADC12	ADC12	ADC12

Other special metallic material available on request.

- AM71□□/SL (Flow direction : Bottom—Top)
 - AM71□□/LB/SL (Flow direction : Bottom—Top, Long body design)
- For liquid and slurry
Rangeability 10:2

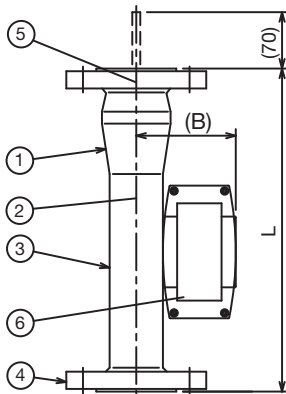

*1 Float rod comes out 70mm during operation in meter size 20mm ~ 150mm. The straight length of downstream pipe with the same size as the flowmeter must be more than 70 mm for a free movement of the float rod. In case of AM71□□/LB/SL (Bottom-Top, Long body design) this coming out is avoided by extending the tube length. The extension length of body (L dimension) is 130mm for 10K (150lbs) version. Consult factory for length of 20K (300lbs) version.

■ Table 3

Figures in () are those of 20K class.

Meter size	Q water (m ³ /h) Rangeability 10:2	Pressure loss (kPa)	10K, Class 150			20K, Class 300		
			L (mm) *1	(B) (mm)	Mass (approx.)	L (mm)	(B) (mm)	Mass (approx.)
15	0.1~0.7(0.7)	6.5	350	94	5	350	94	5
20	1.5 (1.5)	6.0	350	94	5	400	94	6
25	3.9 (3.6)	7.3	350	97	6	400	97	7
40	7.5 (6.8)	9.0	400	104	8	400	104	9
50	15.1 (13.5)	6.3	400	110	10	450	110	12
65	27.5 (26.5)	7.8	450	118	13	500	118	18
80	40.5 (37.5)	9.1	450	125	15	500	125	20
100	75 (65)	12.0	450	137	20	500	137	28
125	110 (—)	14.0	500	150	32	—	—	—
150	150 (—)	18.0	500	163	50	—	—	—

Note: Rangeability for models with the SL code is 10:2.
Note: The mass shown in the table is for the local indicator, and it is also same for the mass in the subsequent tables. In case of "with transmission function," refer to the outside dimension for each model.

■ Table 4

No	Description	Class 1	Class 2	Class 3	Class 4
1	Tapered tube	SUS304	SUS304	SUS316	SUS316L
2	Float ass'y	SUS304	SUS304	SUS316	SUS316L
3	Lower body	SUS304	SUS304	SUS316	SUS316L
4	Flange	SS400	SUS304	SUS316	SUS316L
5	Float guide	SUS304	SUS304	SUS316	SUS316L
6	Indicator	ADC12	ADC12	ADC12	ADC12

Other special metallic material available on request.

- AM71□□/DU (Flow direction : Bottom—Top, with gas damper)
- For gas

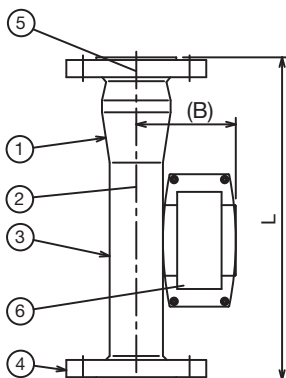

■ Table 5

Meter size	Q air [m ³ /h(nor)]	Pressure loss (kPa)	Size (mm)		Mass (approx.) JIS10K
			L	(B)	
20	16~50	10.0	500	94	5
25	120	10.0	500	97	6
40	210	12.0	500	104	8
50	420	10.0	500	110	10
65	820	16.5	600	118	13
80	1200	23.0	600	125	15
100	2050	24.0	600	137	20

■ Table 6

No	Description	Class 1	Class 2	Class 3	Class 4
1	Tapered tube	SUS304	SUS304	SUS316	SUS316L
2	Float ass'y	SUS304	SUS304	SUS316	SUS316L
3	Lower body	SUS304	SUS304	SUS316	SUS316L
4	Flange	SS400	SUS304	SUS316	SUS316L
5	Float guide	SUS304	SUS304	SUS316	SUS316L
6	Indicator	ADC12	ADC12	ADC12	ADC12

Other special metallic material available on request.

● AM72□□ (Flow direction : Bottom—Top side)

For liquid

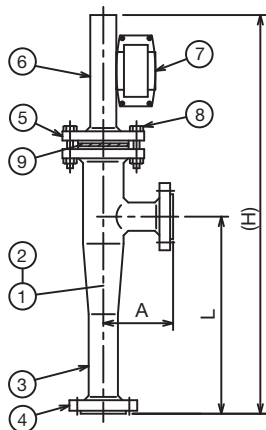

■ Table 7

Figures in () are those of 20K class.

Meter size	Q water (m ³ /h)	Pressure loss (kPa)	10K, Class 150				20K, Class 300			
			(H) (mm)	L (mm)	A (mm)	Mass (approx.)	(H) (mm)	L (mm)	A (mm)	Mass (approx.)
15	0.1~0.69 (0.69)	8.5	650	250	100	8	650	250	100	10
20	1.6 (1.6)	9.1	650	250	100	8	660	250	100	10
25	4.19 (3.6)	6.0	650	250	100	10	670	250	100	12
40	7.73 (5.9)	5.0	670	250	100	12	680	250	100	15
50	15.1 (12.4)	8.0	680	250	100	15	720	250	100	20
65	29.3 (25.0)	6.5	780	350	150	22	810	350	150	28
80	40.8 (34.3)	12.7	820	350	150	25	840	350	180	35
100	70.8 (55.0)	13.6	840	350	150	43	880	350	180	55
125	110 (-)	16.0	860	370	250	55	-	-	-	-
150	150 (-)	21.0	970	480	250	75	-	-	-	-

"H" dimension will be extended by 130mm if a cooling fin is provided.

■ Table 8

No	Description	Class 1	Class 2	Class 3	Class 4
1	Tapered tube	SUS304	SUS304	SUS316	SUS316L
2	Float ass'y	SUS304	SUS304	SUS316	SUS316L
3	Body	SGP *	SUS304	SUS316	SUS316L
4	Flange	SS400	SUS304	SUS316	SUS316L
5	Upper flange	SS400	SS400	SS400	SS400
6	Lead pipe	SUS304	SUS304	SUS316	SUS316L
7	Indicator	ADC12	ADC12	ADC12	ADC12
8	Bolts & nuts	SS400	SS400	SS400	SS400
9	Gasket	Non-asbestos /PTFE	Non-asbestos /PTFE	Non-asbestos /PTFE	Non-asbestos /PTFE

*STPG370 for Medium press. 300 lbs (20K) class.
Other special metallic material available on request.

● AM72□□/SL (Flow direction : Bottom—Top side)

For liquid and slurry

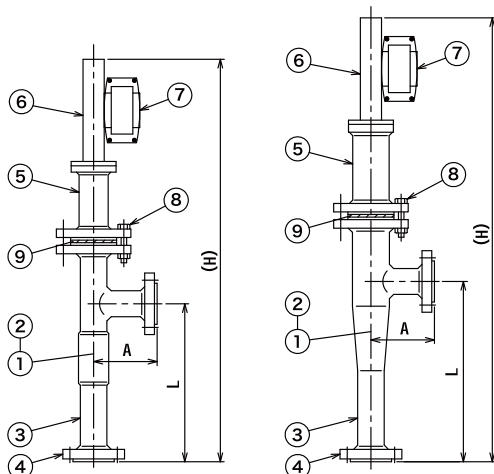

■ Table 9

Meter size	Flow rate (m ³ /h)	Size			Mass (approx.)	Figure
		L (mm)	A (mm)	(H) (mm)		
15	0.1~0.75	250	100	770	9	25
20	1.7	250	100	790	9	26
25	4.2	250	100	790	11	26
40	7.5	250	100	840	13	26
50	15	250	100	860	17	26
65	29.5	350	150	940	24	26
80	40	350	150	990	28	26
100	67	350	150	1010	46	26
125	110	370	250	1030	59	26
150	150	480	250	1140	80	26

■ Table 10

No	Description	Class 1	Class 2	Class 3
1	Tapered tube	SUS304	SUS304	SUS316
2	Float ass'y	SUS304	SUS304	SUS316
3	Body	SGP STPG370	SUS304	SUS316
4	Flange	SS400	SUS304	SUS316
5	Chamber	SS400/SGP	SUS304	SUS316
6	Lead pipe	SUS304	SUS304	SUS316
7	Case	ADC12	ADC12	ADC12
8	Bolt & nuts	SS400 SUS304	SS400 SUS304	SS400 SUS304
9	Gasket	Non-asbestos PTFE	Non-asbestos PTFE	Non-asbestos PTFE

● AM72□□DU

(Flow direction : Bottom—Top side, with gas damper)

For gas

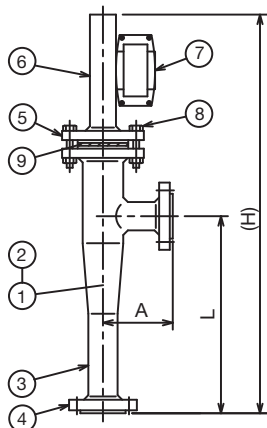

■ Table 11

Meter size	Q air [m ³ /h (nor)]	Pressure loss (kPa)	Size (mm)			Mass (approx.) JIS 10K
			(H)	L	A	
15	2.92~23.1	14.0	690	250	100	8
20	53.3	11.0	690	250	100	8
25	123.7	14.0	690	250	100	10
40	187.8	9.0	690	250	100	12
50	447.1	12.0	700	250	100	15
65	787.4	12.0	800	350	150	22
80	1088	12.0	820	350	150	25
100	1769	11.0	860	350	150	43

■ Table 12

No	Description	Class 1	Class 2	Class 3	Class 4
1	Tapered tube	SUS304	SUS304	SUS316	SUS316L
2	Float ass'y	SUS304	SUS304	SUS316	SUS316L
3	Body	SGP *	SUS304	SUS316	SUS316L
4	Flange	SS400	SUS304	SUS316	SUS316L
5	Upper flange	SS400	SS400	SS400	SS400
6	Lead pipe	SUS304	SUS304	SUS316	SUS316L
7	Indicator	ADC12	ADC12	ADC12	ADC12
8	Bolts & nuts	SS400	SS400	SS400	SS400
9	Gasket	Non-asbestos /PTFE	Non-asbestos /PTFE	Non-asbestos /PTFE	Non-asbestos /PTFE

*STPG370 for Medium press. 300 lbs (20K) class.
Other special metallic material available on request.

● AM73□□

(Flow direction : Bottom side—Top side)

For liquid

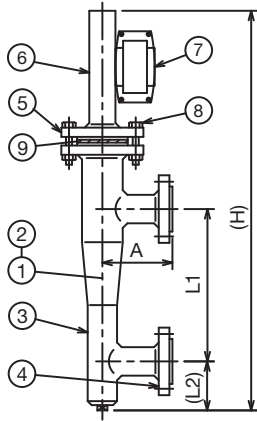

■ Table 13

Figures in () are those of 20K class.

Meter size	Q water (m³/h)	Pressure loss (kPa)	10K, Class 150					20K, Class 300				
			(H) (mm)	L1 (mm)	L2 (mm)	A (mm)	Mass (approx.)	(H) (mm)	L1 (mm)	L2 (mm)	A (mm)	Mass (approx.)
15	0.1~0.69 (0.69)	8.5	690	250	40	100	8	690	250	40	100	10
20	1.6 (1.6)	9.1	690	250	40	100	8	700	250	40	100	10
25	4.19 (3.6)	6.0	690	250	45	100	10	720	250	50	100	12
40	7.73 (5.9)	5.0	720	250	55	100	12	740	250	60	100	16
50	15.1 (12.4)	8.0	740	250	65	100	16	790	250	70	100	21
65	29.3 (25.0)	6.5	860	350	75	150	23	900	350	90	150	30
80	40.8 (34.3)	12.7	910	350	90	150	26	950	350	110	180	37
100	70.8 (55.0)	13.6	940	350	100	150	44	1000	350	120	180	58
125	110 (—)	16.0	980	370	120	250	57	—	—	—	—	—
150	150 (—)	21.0	1110	480	140	250	77	—	—	—	—	—

"H" dimension will be extended by 130mm if a cooling fin is provided.

■ Table 14

No	Description	Class 1	Class 2	Class 3	Class 4
1	Tapered tube	SUS304	SUS304	SUS316	SUS316L
2	Float ass'y	SUS304	SUS304	SUS316	SUS316L
3	Body	SGP *	SUS304	SUS316	SUS316L
4	Flange	SS400	SUS304	SUS316	SUS316L
5	Upper flange	SS400	SS400	SS400	SS400
6	Lead pipe	SUS304	SUS304	SUS316	SUS316L
7	Indicator	ADC12	ADC12	ADC12	ADC12
8	Bolts & nuts	SS400	SS400	SS400	SS400
9	Gasket	Non-asbestos/PTFE	Non-asbestos/PTFE	Non-asbestos/PTFE	Non-asbestos/PTFE

*STPG370 for Medium press. 300 lbs (20K) class.
Other special metallic material available on request.

● AM73□□/DU

(Flow direction : Bottom side—Top side, with gas damper)

For gas

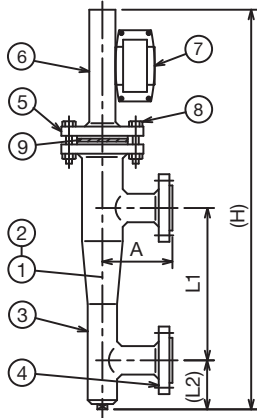

■ Table 15

Meter size	Q air [m³/h(nor)]	Pressure loss (kPa)	Size (mm)				Mass (approx.) JIS 10K
			(H)	L1	(L2)	A	
15	2.92~23.1	17.0	730	250	40	100	8
20	53.3	14.0	730	250	40	100	8
25	123.7	18.0	730	250	45	100	10
40	187.8	12.0	730	250	55	100	12
50	447.1	17.0	760	250	65	100	15
65	787.4	17.0	880	350	75	150	22
80	1088	17.0	910	350	90	150	25
100	1769	16.0	960	350	100	150	43

■ Table 16

No	Description	Class 1	Class 2	Class 3	Class 4
1	Tapered tube	SUS304	SUS304	SUS316	SUS316L
2	Float ass'y	SUS304	SUS304	SUS316	SUS316L
3	Body	SGP *	SUS304	SUS316	SUS316L
4	Flange	SS400	SUS304	SUS316	SUS316L
5	Upper flange	SS400	SS400	SS400	SS400
6	Lead pipe	SUS304	SUS304	SUS316	SUS316L
7	Indicator	ADC12	ADC12	ADC12	ADC12
8	Bolts & nuts	SS400	SS400	SS400	SS400
9	Gasket	Non-asbestos/PTFE	Non-asbestos/PTFE	Non-asbestos/PTFE	Non-asbestos/PTFE

*STPG370 for Medium press. 300 lbs (20K) class.
Other special metallic material available on request.

● AM73□□/DL

(Flow direction : Bottom side—Top side, with liquid damper)

For gas and steam

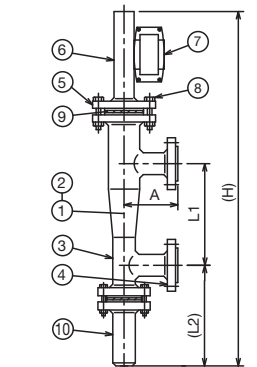

■ Table 17

Figures in () are those of 20K class.

Meter size	Q water (m³/h)	Q air [m³/h(nor)]	Pressure loss (kPa)	10K, Class 150					20K, Class 300				
				(H) (mm)	L1 (mm)	L2 (mm)	A (mm)	Mass (approx.)	(H) (mm)	L1 (mm)	L2 (mm)	A (mm)	Mass (approx.)
15	0.1~0.69 (0.69)	3.1~21.3 (21.3)	10.0	800	220	190	100	11	830	220	210	100	13
20	1.6 (1.6)	53 (53)	12.2	810	220	190	100	11	850	220	220	100	13
25	4.19 (3.6)	129.4 (124)	17.7	830	220	210	100	14	880	220	240	100	17
40	7.73 (5.9)	238 (206)	11.0	860	220	220	100	18	930	220	280	100	22
50	15.1 (12.4)	466 (431)	15.8	960	220	310	100	21	1050	220	370	100	28
65	29.3 (25.0)	904 (831)	19.5	1080	350	300	150	29	1180	350	370	150	38
80	40.8 (34.3)	1260 (1160)	18.0	1130	350	310	150	35	1220	350	380	180	46
100	70.8 (55.0)	2186 (1934)	19.5	1160	350	320	150	53	1280	350	400	180	70
125	110 (—)	3300 (—)	22.0	1220	370	360	250	68	—	—	—	—	—
150	150 (—)	4500 (—)	27.0	1330	480	360	250	90	—	—	—	—	—

"H" dimension will be extended by 130mm if a cooling fin is provided.

■ Table 18

No	Description	Class 1	Class 2	Class 3	Class 4
1	Tapered tube	SUS304	SUS304	SUS316	SUS316L
2	Float ass'y	SUS304	SUS304	SUS316	SUS316L
3	Body	SGP *	SUS304	SUS316	SUS316L
4	Flange	SS400	SUS304	SUS316	SUS316L
5	Upper flange	SS400	SS400	SS400	SS400
6	Lead pipe	SUS304	SUS304	SUS316	SUS316L
7	Indicator	ADC12	ADC12	ADC12	ADC12
8	Bolts & nuts	SS400	SS400	SS400	SS400
9	Gasket	Non-asbestos/PTFE	Non-asbestos/PTFE	Non-asbestos/PTFE	Non-asbestos/PTFE
10	Damper	SUS304	SUS304	SUS316	SUS316L

*STPG370 for Medium press. 300 lbs (20K) class.
Other special metallic material available on request.

● AM76□□, AM77□□

(Flow direction : Left—Right, Right—Left)

For liquid

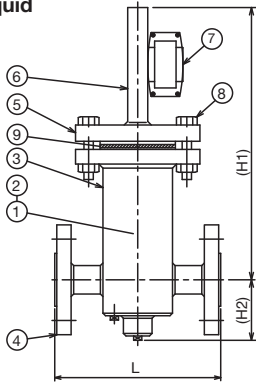

■ Table 19

Meter size	Q water (m³/h)	Pressure loss (kPa)	10K, Class 150				20K, Class 300			
			(H1) (mm)	(H2) (mm)	L (mm)	Mass (approx.)	(H1) (mm)	(H2) (mm)	L (mm)	Mass (approx.)
15	0.1~0.6	11.0	440	80	160	12	440	100	160	14
20	1.4	12.0	470	70	160	12	500	120	160	14
25	3.1	10.0	480	90	180	15	500	120	180	17
40	6.1	15.0	510	80	240	18	520	120	240	21
50	14	11.5	540	80	260	24	550	100	260	28
65	24	10.0	570	80	340	35	580	100	340	42
80	35	16.0	610	80	360	40	620	110	360	50
100	60	18.0	650	90	360	60	660	130	360	75
125	90	20.0	670	110	440	90	—	—	—	—
150	155	25.0	720	130	440	110	—	—	—	—

"H1" dimension will be extended by 130mm if a cooling fin is provided.

■ Table 20

No	Description	Class 1	Class 2	Class 3	Class 4
1	Tapered tube	SUS304	SUS304	SUS316	SUS316L
2	Float ass'y	SUS304	SUS304	SUS316	SUS316L
3	Body	SGP *	SUS304	SUS316	SUS316L
4	Flange	SS400	SUS304	SUS316	SUS316L
5	Upper flange	SS400	SS400	SS400	SS400
6	Lead pipe	SUS304	SUS304	SUS316	SUS316L
7	Indicator	ADC12	ADC12	ADC12	ADC12
8	Bolts & nuts	SS400	SS400	SS400	SS400
9	Gasket	Non-asbestos/PTFE	Non-asbestos/PTFE	Non-asbestos/PTFE	Non-asbestos/PTFE

*STPG370 for Medium press. 300 lbs (20K) class.

Other special metallic material available on request.

● AM76□□/DL, AM77□□/DL

(Flow direction : Left—Right, Right—Left, with liquid damper)

For gas and steam

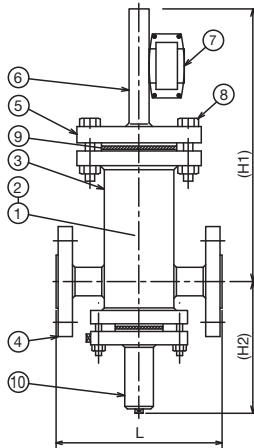

■ Table 21

Meter size	Q water (m³/h)	Q air [m³/h(hor)]	Pressure loss (kPa)	10K, Class 150				20K, Class 300			
				(H1) (mm)	(H2) (mm)	L (mm)	Mass (approx.)	(H1) (mm)	(H2) (mm)	L (mm)	Mass (approx.)
15	0.1~0.7	3.1~18	12.0	440	200	160	15	440	210	160	17
20	1.6	50	14.8	470	200	160	15	500	210	160	17
25	3.5	100	21.0	480	210	180	19	500	230	180	22
40	6.5	200	15.5	510	200	240	24	520	240	240	28
50	13	400	19.0	540	270	260	30	550	290	260	36
65	25	750	22.1	570	280	340	42	580	320	340	52
80	35	1100	21.0	610	290	360	50	620	330	360	62
100	60	1800	24.0	650	300	360	70	660	340	360	90
125	90	2800	26.0	670	320	440	105	—	—	—	—
150	155	4800	31.5	720	340	440	125	—	—	—	—

"H1" dimension will be extended by 130mm if a cooling fin is provided.

■ Table 22

No	Description	Class 1	Class 2	Class 3	Class 4
1	Tapered tube	SUS304	SUS304	SUS316	SUS316L
2	Float ass'y	SUS304	SUS304	SUS316	SUS316L
3	Body	SGP *	SUS304	SUS316	SUS316L
4	Flange	SS400	SUS304	SUS316	SUS316L
5	Upper flange	SS400	SS400	SS400	SS400
6	Lead pipe	SUS304	SUS304	SUS316	SUS316L
7	Indicator	ADC12	ADC12	ADC12	ADC12
8	Bolts & nuts	SS400	SS400	SS400	SS400
9	Gasket	Non-asbestos/PTFE	Non-asbestos/PTFE	Non-asbestos/PTFE	Non-asbestos/PTFE
10	Damper	SUS304	SUS304	SUS316	SUS316L

*STPG370 for Medium press. 300 lbs (20K) class.

Other special metallic material available on request.

● AM71□□/JS, AM71□□/JF

(Flow direction : Bottom—Top, with jacket)

For liquid

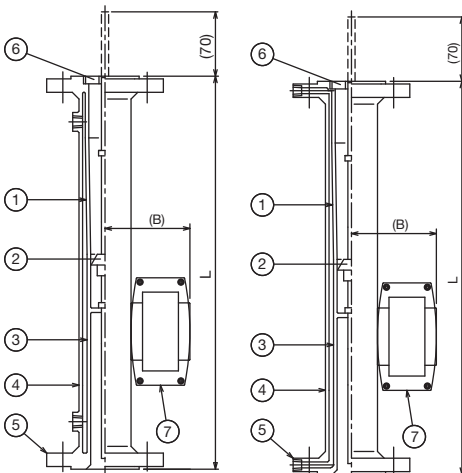

■ Table 23

Meter size	Q water (m³/h)	Pressure loss (kPa)	10K, Class 150			20K, Class 300		
			L (mm)	(B) (mm)	Mass (approx.)	L (mm)	(B) (mm)	Mass (approx.)
15	0.1~0.7	6.5	350	98	6	350	98	6
20	1.5	6.0	400	98	6	400	98	7
25	3.8	7.3	400	101	7	400	101	8
40	7.15	9.0	400	108	10	400	108	11
50	15.1	6.3	450	118	12	450	118	14
65	26.5	7.8	500	125	16	500	125	21
80	39.5	9.1	500	131	18	500	131	23
100	67.5	12.0	500	150	25	500	150	33
125	110	14.0	500	163	38	—	—	—
150	150	18.0	500	176	60	—	—	—

*1 Float rod comes out by 70mm during operation in meter sizes 20mm ~ 150mm.

The straight length of downstream pipe with the same size as the flowmeter must be more than 70 mm for a free movement of the float rod.

■ Table 24

No	Description	Class 1	Class 2	Class 3	Class 4
1	Tapered tube	SUS304	SUS304	SUS316	SUS316L
2	Float ass'y	SUS304	SUS304	SUS316	SUS316L
3	Body	SUS304	SUS304	SUS316	SUS316L
4	Jacket pipe	SUS304	SUS304	SUS304	SUS304
5	Flange	SS400	SUS304	SUS316	SUS316L
6	Float guide	SUS304	SUS304	SUS316	SUS316L
7	Indicator	ADC12	ADC12	ADC12	ADC12

● AM71□□/JS/SL, AM71□□/JF/SL

(Flow direction : Bottom—Top, with jacket)
For liquid and slurry

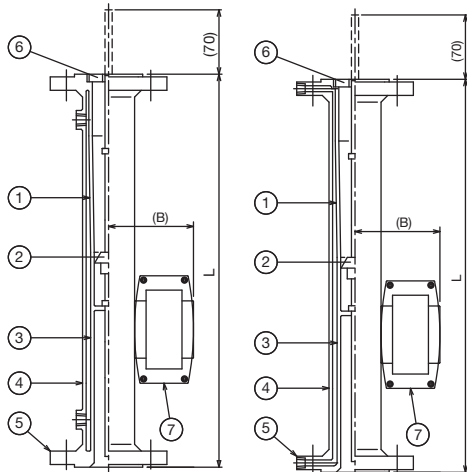

■ Table 25

Meter size	Q water (m³/h)	Pressure loss (kPa)	10K. Class 150			20K. Class 300		
			L *1 (mm)	(B) (mm)	Mass (approx.)	L (mm)	(B) (mm)	Mass (approx.)
15	0.1~0.7	6.5	350	98	6	350	98	6
20	1.5	6.0	400	98	6	400	98	7
25	3.6	7.3	400	101	7	400	101	8
40	6.8	9.0	400	108	10	400	108	11
50	13.5	6.3	450	118	12	450	118	14
65	26.5	7.8	500	125	16	500	125	21
80	37.5	9.1	500	131	18	500	131	23
100	65	12.0	500	150	25	500	150	33
125	100	14.0	500	163	38	—	—	—
150	140	18.0	500	176	60	—	—	—

*1 Float rod comes out by 70mm during operation in meter sizes 20mm ~ 150mm. The straight length of downstream pipe with the same size as the flowmeter must be more than 70 mm for a free movement of the float rod.

■ Table 26

No	Description	Class 1	Class 2	Class 3	Class 4
1	Tapered tube	SUS304	SUS304	SUS316	SUS316L
2	Float ass'y	SUS304	SUS304	SUS316	SUS316L
3	Body	SUS304	SUS304	SUS316	SUS316L
4	Jacket pipe	SUS304	SUS304	SUS304	SUS304
5	Flange	SS400	SUS304	SUS316	SUS316L
6	Float guide	SUS304	SUS304	SUS316	SUS316L
7	Indicator	ADC12	ADC12	ADC12	ADC12

● AM72□□/JS, AM72□□/JF

(Flow direction : Bottom—Top side, with jacket)
For liquid

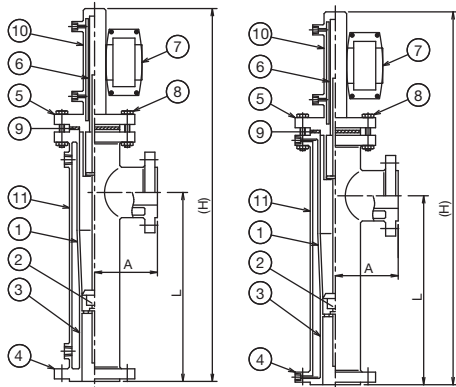

■ Table 27

Meter size	Q water (m³/h)	Pressure loss (kPa)	10K. Class 150				20K. Class 300			
			(H) (mm)	L (mm)	A (mm)	Mass (approx.)	(H) (mm)	L (mm)	A (mm)	Mass (approx.)
15	0.1~0.69	8.5	660	250	100	12	660	250	100	14
20	1.6	9.1	680	250	100	12	680	250	100	14
25	3.6	6.0	670	250	100	15	670	250	100	17
40	5.9	5.0	680	250	130	18	690	250	130	21
50	12.4	8.0	710	250	130	22	750	250	130	27
65	25.0	6.5	820	350	150	30	850	350	150	36
80	34.3	12.7	850	350	180	35	870	350	180	55
100	55.0	13.6	900	350	180	58	940	350	180	70
125	110.0	16.0	940	370	250	72	—	—	—	—
150	150.0	21.0	1050	480	250	95	—	—	—	—

Only General purpose 150 lbs (10K) class is available for full jacketed version. (AM7□□□/JF)

■ Table 28

No	Description	Class 1	Class 2	Class 3	Class 4
1	Tapered tube	SUS304	SUS304	SUS316	SUS316L
2	Float ass'y	SUS304	SUS304	SUS316	SUS316L
3	Body	SGP *	SUS304	SUS316	SUS316L
4	Flange	SS400	SUS304	SUS316	SUS316L
5	Upper flange	SS400	SUS304	SUS316	SUS316L
6	Lead pipe	SUS304	SUS304	SUS316	SUS316L
7	Indicator	ADC12	ADC12	ADC12	ADC12
8	Bolts & nuts	SS400	SS400	SS400	SS400
9	Gasket	Non-asbestos /PTFE	Non-asbestos /PTFE	Non-asbestos /PTFE	Non-asbestos /PTFE
10	Upper jacket pipe	SUS304	SUS304	SUS304	SUS304
11	Jacket pipe	SGP or STPG370 (Depending on jacket medium press.)			

*STPG370 for Medium press. 300 lbs (20K) class. Other special metallic material available on request.

[RUBBER AND ETFE LINED MATERIAL]

● AM71□□ (Flow direction : Bottom—Top)

For liquid

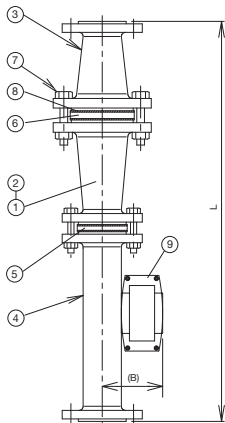

■ Table 29

Meter size	Q water (m³/h)	Pressure loss (kPa)	Size (mm)		Mass (approx.)
			L	(B)	
15	0.1~0.65	5.0	550	94	16
20	1.2	6.0	550	94	18
25	2.8	6.0	550	97	22
40	6.5	9.0	600	104	28
50	11.5	6.0	650	110	35
65	17.0	8.0	700	118	45
80	34.0	9.0	750	125	55
100	60.0	11.0	750	137	70
125	90.0	13.0	750	150	85
150	140.0	17.0	800	163	120

■ Table 30

No	Description	Class 1	Class 2
1	Tapered tube	Rubber lined	Rubber lined
2	Float ass'y	PVC *1	F.C.R. *2
3	Upper body	Rubber lined	Rubber lined
4	Lower body	Rubber lined	Rubber lined
5	Float guide (L)	PVC	PVDF
6	Float guide (U)	PVC	PVDF
7	Bolts & nuts	SS400	SS400
8	Gasket	EPDM	EPDM
9	Indicator	ADC12	ADC12

*1 Float rod material is ETFE lined SUS304 for meter size 15 and 20mm.

*2 Float rod material is ETFE lined SUS304 for meter size 15, 20, 25 and 40mm.

■ Table 31

No	Description	Class 1
1	Tapered tube	F.C.R. lined
2	Float ass'y	F.C.R. lined *2
3	Upper body	F.C.R. lined
4	Lower body	F.C.R. lined
5	Float guide (L)	PVDF
6	Float guide (U)	PVDF
7	Bolts & nuts	SS400
8	Gasket	PTFE
9	Indicator	ADC12

F.C.R. means Fluorocarbon Resin.

● AM72□□ (Flow direction : Bottom—Top side)

For liquid

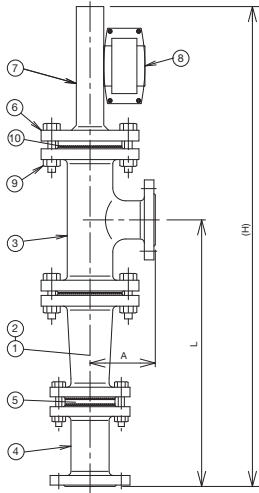

■ Table 32

Meter size	Q water (m³/h)	Pressure loss (kPa)	Size (mm)			Mass (approx.) JIS10K
			(H)	L	A	
15			Not available			
20			Not available			
25	0.8~2.7	5.5	700	320	120	17
40	4.8	4.3	730	350	130	22
50	11.4	7.0	780	380	130	24
65	20.2	5.4	810	400	150	28
80	33.0	10.0	870	440	150	34
100	54.0	10.0	1000	500	200	52
125	88.0	14.0	1020	500	200	65
125	88.0	14.0	1140	550	220	70
150	140.0	20.0	1150	600	220	95

*1 Class 1, 2 *2 Class 3

■ Table 33

No	Description	Class 1	Class 2
1	Tapered tube	Rubber lined	Rubber lined
2	Float ass'y	PVC *	F.C.R. *
		Other metallic material on request	
3	Upper body	Rubber lined	Rubber lined
4	Lower body	Rubber lined	Rubber lined
5	Float guide (L)	PVC	PVDF
6	Float guide (U)	PVC	PVDF
7	Bolts & nuts	SS400	SS400
8	Gasket	EPDM	EPDM
9	Indicator	ADC12	ADC12

* Float rod material is ETFE lined SUS304 for meter size 15, 20 and 25mm.

■ Table 34

No	Description	Class 1
1	Tapered tube	F.C.R. lined
2	Float ass'y	F.C.R. lined *
		Other metallic material on request
3	Upper body	F.C.R. lined
4	Lower body	F.C.R. lined
5	Float guide (L)	PVDF
6	Float guide (U)	PVDF
7	Bolts & nuts	SS400
8	Gasket	PTFE
9	Indicator	ADC12

F.C.R. means Fluorocarbon Resin.

[PVC LINED MATERIAL]

● AM71□□, AM71□□/SL

(Flow direction : Bottom—Top)

For liquid

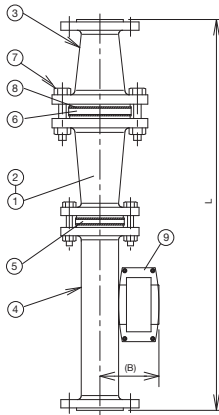

■ Table 35

Meter size	Q water (m³/h)	Pressure loss (kPa)	Size (mm)		Mass (approx.) JIS10K
			L	(B)	
15	0.1~0.65	5.0	550	94	16
20	1.1	5.0	700	94	20
25	2.1	5.5	750	101	25
40	2.7	8.0	800	104	32
50	6.5	5.5	850	110	40
65	12	7.0	900	118	50
80	17	8.0	900	131	62
100	35	10.0	950	137	78
125	48	12.0	950	150	94
150	66	16.0	1000	163	130

■ Table 36

No	Description	Material
1	Tapered tube	PVC lined
2	Float ass'y	PVC *
3	Upper body	PVC lined
4	Lower body	PVC lined
5	Float receiver	PVC
6	Float guide	PVC
7	Bolts & nuts	SS400
8	Gasket	EPDM
9	Indicator	ADC12

* Float rod material is ETFE lined SUS304 for meter size 15 and 20mm.

● AM72□□ (Flow direction : Bottom—Top side)

For liquid

A slurry type is available. For details, contact us.

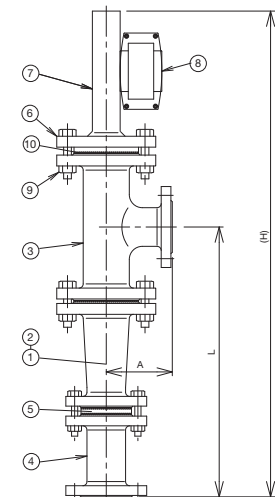

■ Table 37

Meter size	Q water (m³/h)	Pressure loss (kPa)	Conn size	Size (mm)			Mass (approx.) JIS10K
				(H)	L	A	
15				Not available			
20				Not available			
25	0.6~1.9	5.0	20	850	420	70	18
			25	830	400	49	
			40	830	400	61	
40	2.6	3.8	25	850	420	54	22
			40	850	420	64	
			50	850	420	67	
50	5.8	6.0	40	930	480	70	25
			50	930	480	74	
			65	930	480	80	
65	11	4.8	50	980	520	80	30
			65	980	520	86	
			80	980	520	90	
80	18	8.5	65	1010	530	99	46
			80	1010	530	103	
			100	1010	530	110	
100	29.5	8.5	80	1050	553	128	53
			100	1050	553	135	
			125	1050	553	141	
125	45	12.0	100	1100	600	135	65
			125	1100	600	141	
			150	1100	600	190	
150	76	17.0	125	1140	641	167	95
			150	1150	650	210	
			200	1150	650	220	

■ Table 38

No	Description	Material
1	Tapered tube	PVC lined
2	Float ass'y	PVC
3	Upper body	PVC lined
4	Lower body	PVC lined
5	Float guide	PVC
6	Upper flange	SS400
7	Lead pipe	PVC
8	Indicator	ADC12
9	Bolts & nuts	SS400
10	Gasket	EPDM

[GLASS LINED MATERIAL]

● AM71□□ (Flow direction : Bottom—Top)
For liquid

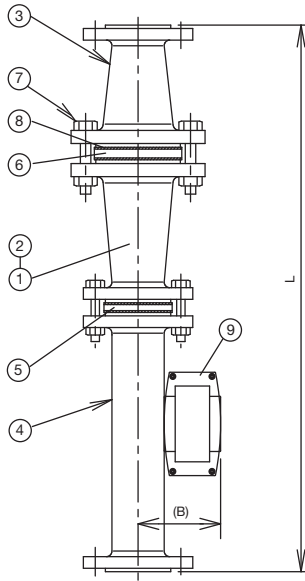

■ Table 39

Meter size	F.C.R. Float		MA276 Float		Conn size	Size (mm)		Mass (approx.) JIS10K	
	Q water (m³/h)	Pressure loss (kPa)	Q water (m³/h)	Pressure loss (kPa)		L	(B)		
15	0.1~0.4	6.0	0.1~0.6	10.0	20	570	97	18	
					25	552			
20	Not available								
25	1	0.8	8.0	1.0	10.0	20	768	97	26
						25	710		
						40	806		
	2	1.3	6.0	1.6	8.0	20	781	97	25
						25	688		
						40	840		
40	1	1.7	6.0	2.5	8.0	25	875	104	35
						40	803		
						50	867		
	2	3.2	6.0	4.5	8.0	40	750	104	33
						50	903		
						50	790		
50	6.5	6.0	8	8.0	80	943	110	40	
65	Not available								
80	17	9.0	20	10.5	80	835	125	55	
					100	987			
100	35	9.0	45	11.5	100	870	137	70	
					150	1024			
125	Not available								
150	Not available								

■ Table 40

No	Description	Class 1	Class 2	
1	Tapered tube	Glass lined	Glass lined	
2	Float ass'y	F.C.R. *	MA276	F.C.R. means
3	Upper body	Glass lined	Glass lined	Fluorocarbon
4	Lower body	Glass lined	Glass lined	Resin.
5	Float receiver	PVDF	MA276	
6	Float guide	PVDF	MA276	
7	Bolts & nuts	SS400	SS400	
8	Gasket	PTFE	PTFE	
9	Indicator	ADC12	ADC12	

*Float rod material is ETFE lined SUS304 for meter size 15, 20, 25 and 40mm.

● AM72□□ (Flow direction : Bottom—Top side)
For liquid

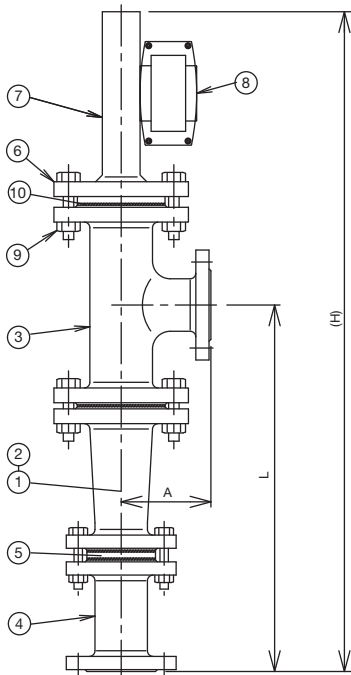

■ Table 41

Meter size	F.C.R. Float		MA276 Float		Conn size	Size (mm)			Mass (approx.) JIS10K	
	Q water (m³/h)	Pressure loss (kPa)	Q water (m³/h)	Pressure loss (kPa)		(H)	L	A		
15	Not available									
20	Not available									
25	1	0.3~0.79	8.0	0.4~1.0	10.0	20	740	362	78	27
						25	850	470		
						40	760	380		
	2	1.3	6.0	1.6	8.0	20	780	378	95	30
						25	890	486		
						40	800	398		
40	1	2.1	7.0	2.7	9.0	25	830	422	95	33
						40	920	512		
						50	820	418		
	2	2.8	6.0	3.6	8.0	25	840	418	102	37
						40	920	508		
						50	820	414		
50	7.8	7.0	10	8.5	40	900	450	126	47	
					50	980	544			
65	Not available									
80	15	9.0	19	10.5	50	980	526	143	60	
					80	1050	596			
					100	980	526			
100	34	9.0	44	11.5	80	1210	580	173	82	
					100	1280	650			
					150	1220	590			
					150	1220	590			
125	Not available									
150	Not available									

■ Table 42

No	Description	Class 1	Class 2	
1	Tapered tube	Glass lined	Glass lined	
2	Float ass'y	F.C.R. *	MA276	F.C.R. means
3	Upper body	Glass lined	Glass lined	Fluorocarbon
4	Lower body	Glass lined	Glass lined	Resin.
5	Float buide	PVDF	MA276	
6	Upper flange	SS400	SS400	
7	Lead pipe	FEP tubed SUS304		
8	Indicator	ADC12	ADC12	
9	Bolts & nuts	SS400	SS400	
10	Gasket	PTFE	PTFE	

*Float rod material is ETFE lined SUS304 for meter size 15, 20 and 25mm.

● AM73□□/DL

(Flow direction : Bottom side—Top side,
with liquid damper)

For gas

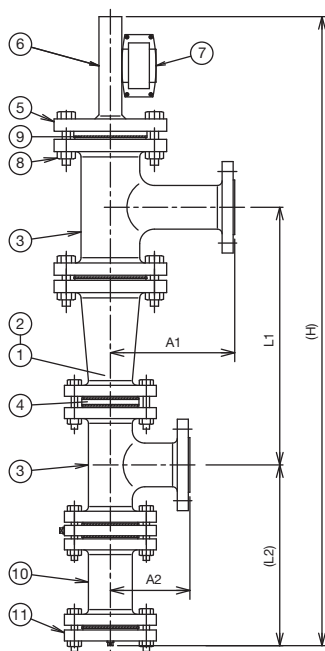

■ Table 43

Meter size	F.C.R. Float		MA276 Float		Conn size	Size (mm)					Mass (approx.) JIS10K	
	Q air [m³/h(nor)]	Pressure loss (kPa)	Q air [m³/h(nor)]	Pressure loss (kPa)		(H)	L1	(L2)	A1	A2		
15	Not available											
20	Not available											
25	1	10~26	9.0	12~33	11.0	20	1010	348	280	78	78	33
						25				190	190	
						40						
25	2	42	7.0	54	9.5	20	1050	365	280	78		37
						25				95	190	
						40						
40	1	70	7.5	90	10.0	25	1110	406	300	95	95	40
						40				203	203	
						50						
40	2	90	6.5	115	9.0	25	1120	404	300	102	95	45
						40				203	203	
						50						
50		240	8.0	300	9.0	40	1190	446	310	102		60
						50				126	102	
						80				234		
65	Not available											
80		510	10.0	650	11.5	50	1300	521	330	143	126	75
						80				259		
						100						
100		1140	12.0	1460	14.0	80	1560	592	350	173	143	100
						100				285		
						150						
125	Not available											
150	Not available											

■ Table 44

No	Description	Class 1	Class 2	
1	Tapered tube	Glass lined	Glass lined	
2	Float ass'y	F.C.R. *	MA276	F.C.R. means
3	Body	Glass lined	Glass lined	Fluorocarbon
4	Float buide	PVDF	MA276	Resin.
5	Upper flange	SS400	SS400	
6	Lead pipe	FEP tubed SUS304		
7	Indicator	ADC12	ADC12	
8	Bolts & nuts	SS400	SS400	
9	Gasket	PTFE	PTFE	
10	Damper	Glass lined	Glass lined	
11	Blind flange	SS400/PTFE	SS400/PTFE	

*Float rod material is ETFE lined SUS304 for meter size 15, 20 and 25mm.

SELECTION OF FLOWMETER

1. Liquid application

a. Selection of meter size

Maximum possible flow rate each meter size is shown in dimension tables from Page 15 to 22. These figures are based on water flow (Density 1.0g/cm³ and Viscosity 1.0MPa·s). If actual fluid condition is different from such figures, a conversion calculation is required as following formula:

$$Q_w = Q \times 2.59 / \sqrt{(7.7/\rho) - 1}$$

Q_w : Water converted flow rate (m³/h)

Q : Flow rate of actual fluid (m³/h)

ρ : Density of actual fluid (g/cm³)

Example Fluid: Alcohol Density: 0.8g/cm³
 Flow rate: 50m³/h Flowmeter to be used: AM71□□

$$\begin{aligned} Q_w &= 50 \times 2.59 / \sqrt{(7.7/0.8) - 1} \\ &= 50 \times 0.882 \\ &= 44.1 (\text{m}^3/\text{h}) \end{aligned}$$

Referring to table 1 on Page 15, the required meter size is 100. For possible connection flange sizes, refer to Table 45.

b. Viscosity limit

In case the Viscosity of fluid is more than 1mPa·s, confirm the suitability shown in the figure below. Trace viscosity and flow rate and confirm the crossing point is below the curve. If the crossing point is above the curve, consult factory for detailed calculation by computer.

● Viscosity curve

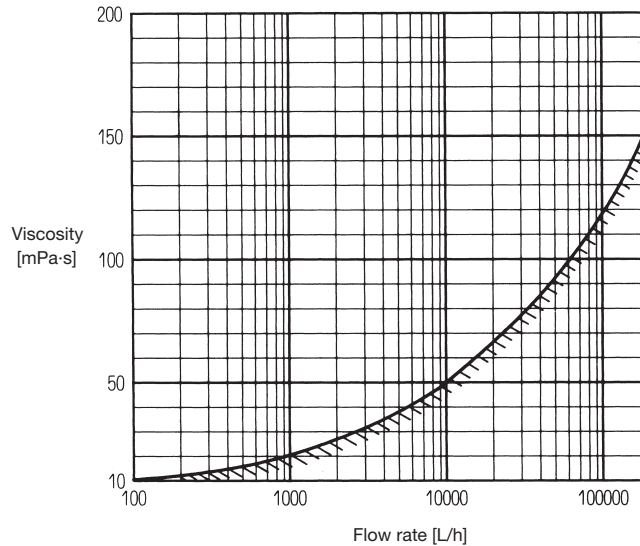

c. Slurry application

Consult factory if contaminations, sand, dirt and other solid particles are expected in fluid. AM7□□□/SL series slurry flowmeter is available.

2. Gas application

Generally, flowmeters with damper (Model AM71□□/DU, AM72□□/DU, AM73□□/DU, AM73□□/DL, AM76□□/DL, AM77□□/DL) are recommended for gas application to prevent float vibration.

Selection of meter size

Maximum possible flow rate for each meter size is shown in dimension tables of AM71□□/DU, AM72□□/DU, AM73□□/DU, AM73□□/DL, AM76□□/DL, and AM77□□/DL flowmeters.

If actual fluid condition is different from such figures, a conversion calculation is to be performed by the following formula:

$$Q_A = Q \times 0.0169 \times \sqrt{\rho \times (273+t) / (0.1013+p)}$$

Q_A : Converted flow rate in air 0°C, 1atm [m³/h(nor)]

ρ : Density of gas to be measured [kg/m³(nor)]

p : Pressure of gas to be measured (MPa)

t : Operating temperature (°C)

Example Gas to be measured : Nitrogen (N₂) Specific weight (ρ) : 1.251kgf/m³(nor)
 Operating pressure (p) : 0.6MPa Operating temperature (t) : 20°C
 Flowmeter to be used : AM73□□/DU

$$\begin{aligned} Q_A &= 300 \times 0.0169 \times \sqrt{1.251 \times (273+20) / (0.1013+0.6)} \\ &= 300 \times 0.0169 \times 22.86 \\ &= 115.9 [\text{m}^3/\text{h} (\text{nor})] \end{aligned}$$

Referring to table 15 on Page 17, the suitable meter size is 25. For possible connection flange sizes, refer to Table 45.

3. Steam application

Flowmeters with liquid damper (type AM73□□/DL, AM76□□/DL, AM77□□/DL) are recommended for steam application to prevent float vibration. Also a cooling fin is normally needed because of high temperature.

Selection of meter size

Steam flow rate is to be converted into water flow rate by the following formula for size determination.

$$Q_w = Q_s \times 0.03 \times \sqrt{\rho}$$

Q_w : Water converted flow rate (m³/h)

Q_s : Steam flow rate (m³/h)

ρ : Density of steam (kg/m³)

Example Fluid Saturated : Steam Pressure : 0.9MPa
 Flow rate : 1t/h Flowmeter to be used : AM76□□/DL

First, density of the steam is to be obtained from “Steam graph” etc. In this application, density(ρ) of 0.9MPa steam is 5.1kg/m³. Saturated steam curve (by temperature) is shown in the figure below and saturated steam curve (by pressure) is shown in the figure below for reference. Normally, flow rate of steam is described in weight unit, which is to be converted to volume unit (Q_s) as follows:

$$\begin{aligned} 1t/h &= 1000 \text{ kg/h} \\ Q_s &= 1000 \text{ kg/h} / 5.1 \text{ kg/m}^3 \\ &= 196 \text{ m}^3/\text{h} \end{aligned}$$

Then, all these figures are to be put into the formula:

$$\begin{aligned} Q_w &= 196 \times 0.03 \times \sqrt{5.1} \\ &= 196 \times 0.0677 \\ &= 13.3 \text{ (m}^3/\text{h)} \end{aligned}$$

Referring to Table 21 on Page 18, the suitable meter size is 65. For possible connection flange sizes, refer to Table 45.

● Density of saturated Steam (by temperature)

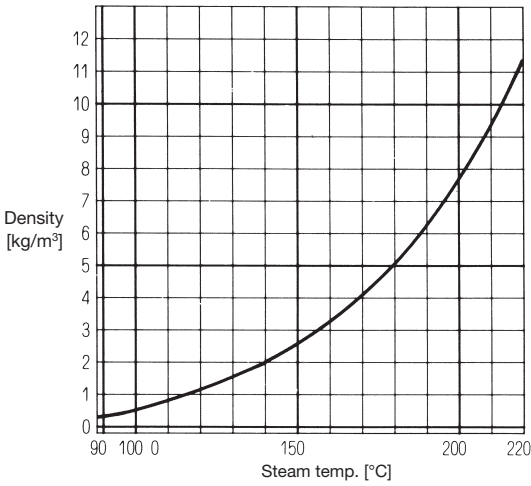

● Density of saturated Steam (by pressure)

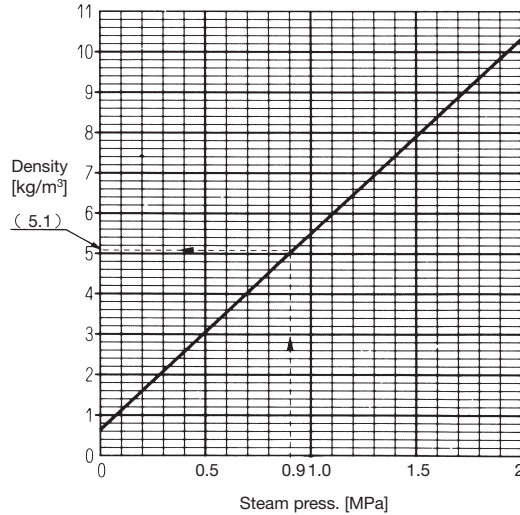

4. Connection flanges

Table 45 shows possible connection flange sizes against selected meter sizes. The table is applicable for flowmeters with Metallic materials, Rubber lining, ETFE lining.

Only listed connection sizes in dimension tables are available for flowmeters with PVC lining and Glass lining.

■ **Table 45**

Model	Flow direction	Against meter size		
		-1 size	±0 size	+1 size
AM71□□	Bottom – Top	×	○	○
AM71□□/JS, JF	Bottom – Top	×	×	○
AM72□□	Bottom – Top side	○	○	○
AM72□□/JS, JF	Bottom – Top side	×	○	○
AM73□□	Bottom side – Top side	○	○	○
AM76□□	Left – Right	○	○	○
AM77□□	Right – Left	○	○	○

5. Scale graduation

Customer can select any one of the following 16 standard scale graduations if meter size and connection flange meet the specification. Range ability is 10 : 1

Example If required scale range is 150–1500 m³/h (nor), the graduation on the flowmeter will be 15–150×10 m³/h (nor)

● **Standard scale graduation**

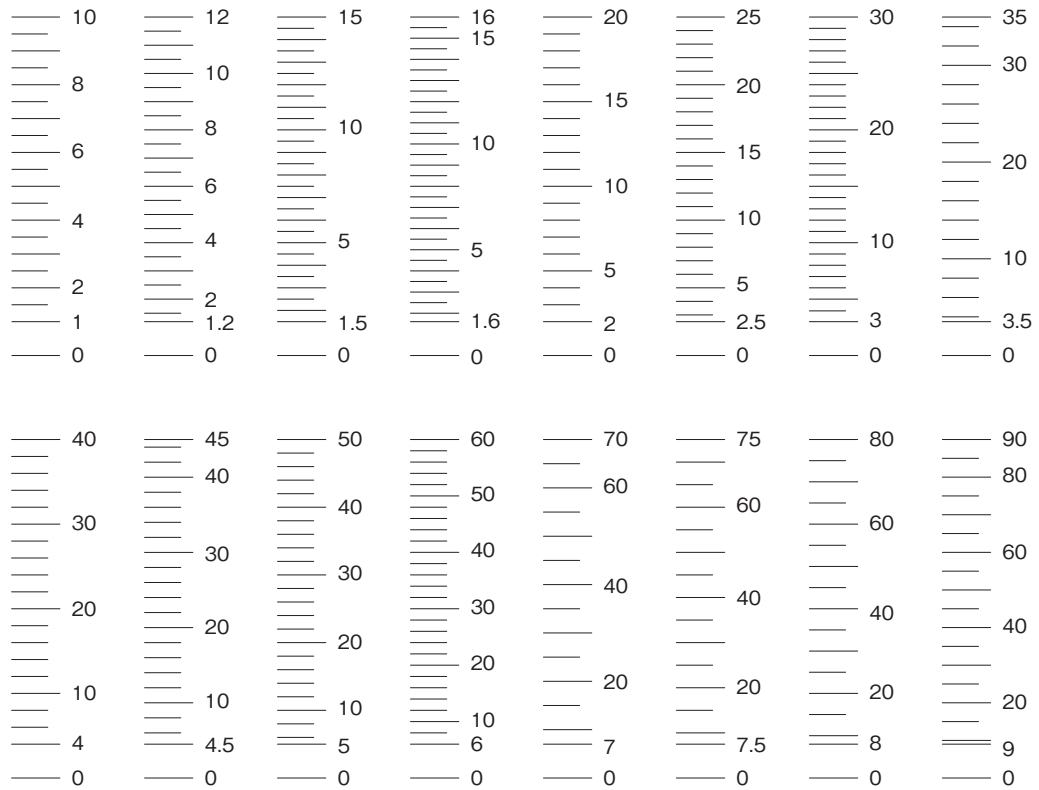

6. Special orders

a. Low pressure drop version

If standard pressure drop does not meet the requirement, “Low pressure drop version” is available on request. Consult factory for further details.

b. Low temperature application

If the fluid temperature is very low (i.e. liquefied gas etc.), Special arrangement to prevent frost is available. Consult factory for further detail.

c. High pressure application

Up to 196 MPa possible with experience. Consult factory for further details.

CAUTIONS

- This flowmeter transmits the displacement caused by the magnet coupling. A surrounding magnetic field might affect its performance.
- Avoid installation near magnetic fields. Magnetic materials including insulation covers may also affect its performance; do not bring them within 20 cm from the flowmeter.
- When installing two or more flowmeters, place them at least the distances shown in the figures below apart from each other to avoid mutual interference.

For maintenance, ensure a clearance of at least 20 cm between the indicator of one flowmeter and the body of other flowmeters.

Local indication and alarm output type

For a meter size of 50 or less: at least 35 cm
For a meter size of 65 or more: at least 45 cm

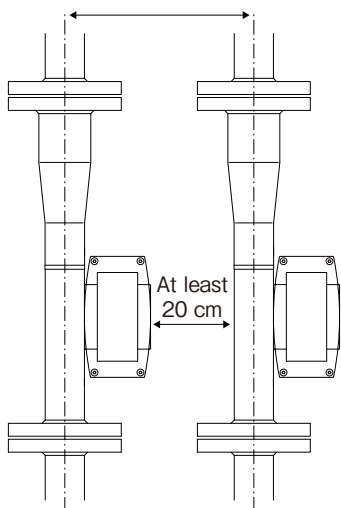

Electric transmitter and alarm output (Flameproof) type

For a meter size of 50 or less: at least 35 cm
For a meter size of 65 or more: at least 45 cm

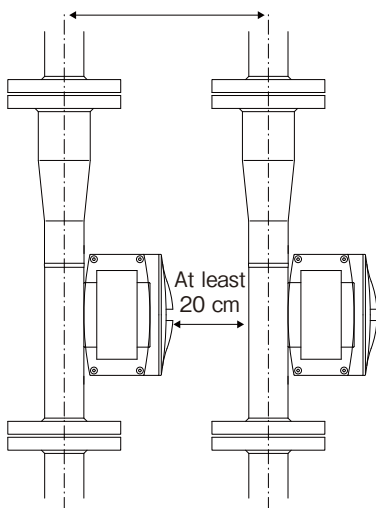

Local integration type

For a meter size of 50 or less: at least 40 cm
For a meter size of 65 or more: at least 50 cm

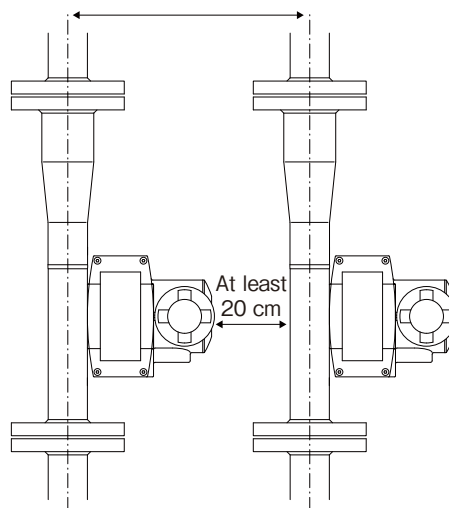

* Specification is subject to change without notice.

TIV TOKYO KEISO CO., LTD.

Head Office : Shiba Toho Building, 1-7-24 Shibakoen, Minato-ku, Tokyo 105-8558

Tel : +81-3-3431-1625 (KEY) ; Fax : +81-3-3433-4922

e-mail : overseas.sales@tokyokeiso.co.jp ; URL : <https://www.tokyokeiso.co.jp>