

## OUTLINE

The **SONICMAX<sup>®</sup> UL3400** is an ultrasonic flowmeter for inline liquid measurement with 3 pairs of ultrasonic sensors. The 3-beam measuring method and digital signal processor (DSP) offer highly accurate, stable measurement in a broad range of applications. The **UL3400** can be used independently of changes in physical or chemical properties of liquids such as density, viscosity or electric conductivity. A wide range of sizes spanning 25 to 2000 mm are available.

## FEATURES

- ❑ 3-ultrasound beam technology enables highly accurate measurement ranging from laminar to turbulent flow.
- ❑ The digital signal processor ensures stable measurement and minimizes the influence of bubbles and particles.
- ❑ No moving parts and maintenance-free. Suitable for measuring a variety of liquids including oil and solvent, as well as for replacing turbines or PD flowmeters
- ❑ Easy installation with compact design
- ❑ 4 to 20 mA current output, pulse output, and status output
- ❑ Explosionproof types are available; TIIS approved, and ATEX
- ❑ Complying with: RoHS Decision No. 2011/65/EU

## STANDARD SPECIFICATIONS

- Measuring method : Time – flight ultrasound, 3 beams
- Nominal size : 25, 32, 40, 50, 65, 80, 100, 125, 150, 200, 250, 300, 350, 400, 500, 600, 700, 800, 900, 1000, 1200, 1400, 1600, 1800, 2000 mm  
\*Note: Contact Tokyo Keiso for the size over 2000 mm
- Measuring range : Flow velocity : Min. 0 to 0.3 m/s  
: Max. 0 to 20 m/s  
\*Note: See “FLOW RANGE” table for details.
- Protection class : Compact type : IP66/67 (IEC60529)  
Separate type Converter: IP66/67 (IEC60529)  
Separate type Sensor  
(Standard Extended temperature version) :  
IP66/67, IP68 (IEC60529) (Option)  
Separate type Sensor (Cryogenic version) :  
IP68 (IEC60529) (Standard)
- Ambient temperature : Compact type (Converter housing material :  
Aluminium alloy) : –40°C to +65°C  
Compact type (Converter housing material :  
SS316) : –40°C to +60°C  
Separate type sensors : –40°C to +65°C  
Separate type (Converter housing material :  
[Standard] Aluminium alloy) : –40°C to +65°C  
Separate type (Converter housing material :  
[Option] SS316) : –40°C to +60°C  
\*Note : See “Explosionproof specifications”  
for the allowable ambient  
temperature of the explosionproof  
types.



## Fluids

- Measuring fluid : Liquids in which Ultrasonic waves propagate  
\*Refer to P12. [POINTS TO BE CHECKED BEFORE MODEL SELECTION]
- Temperature : –45°C to +140°C (Compact type)  
–45°C to +180°C (Separate type / Standard version)  
–45°C to +250°C (Separate type / Extended temperature version)  
–200°C to +180°C (Separate type / Cryogenic version)  
\*Refer to the EX specification for Ambient temperature of EX product.
- Pressure : Max. 10 MPa as per flange rating
- Kinetic viscosity : Max. 100 cSt

Sensors

●Material

Standard version

			Size 25 to 65 mm	Size 80 to 300 mm	Size 350 to 2000 mm
Wetted part	Measuring tube	Standard	SS316	Carbon steel	Carbon steel
		Option		SS316	SS316
	Flange	Standard	SS316L	Carbon steel	Carbon steel
		Option		SS316L	SS316L
Sensor housing / Sensor window			SS316L	SS316L	SS316L
Body	Measuring sensor housing	Standard	SS316L	Carbon steel	
		Option		SS316L	
	Transducer	Standard			SS316L

Extended temperature version

			Size 25 to 65 mm	Size 80 to 300 mm	Size 350 to 2000 mm
Wetted part	Measuring tube	Standard	SS316	Carbon steel	Carbon steel
		Option		SS316	SS316
	Flange	Standard	SS316L	Carbon steel	Carbon steel
		Option		SS316L	SS316L
Sensor housing / Sensor window			SS316L	SS316L	SS316L
Body	Measuring sensor housing	Standard	SS316L	Carbon steel	Carbon steel
		Option		SS316L	SS316L
	Transducer	Standard			

Cryogenic version

			Size 25 to 65 mm	Size 80 to 300 mm	Size 350 to 2000 mm
Wetted part	Measuring tube	Standard	SS316	SS316	SS316
		Option			
	Flange	Standard	SS316L	SS316L	SS316L
		Option			
Sensor housing / Sensor window			SS316L	SS316L	SS316L
Body	Measuring sensor housing	Standard	SS316L	SS316L	SS316L
		Option			
	Transducer	Standard			

●Process connection : Flanges

- Type of flanges : Equivalent to JIS10K, JIS20K  
ASME class 150, 300, 600  
EN1092-1 PN6, 10, 16, 25, 40, 63, 100

●Painting : Polysiloxane epoxy resin paint

●Color : Gray

●Sensor cable entry (Separate type)

- : 1 × G1/2 female with adapter
- : 1 × 1/2NPT female with adapter
- : 1 × M20 female with waterproof ground

Converter

●Housing material : Aluminium alloy (Option : SS316)

●Painting : Polysiloxane epoxy resin paint

●Color : Gray (Converter body), Jade green (Converter cover, Terminal box cover)

●Power supply : 100 to 230 V AC (85 to 253 V)  
24 V DC (11 to 31 V)  
Figures in parenthesis are the acceptable range of voltage.

●Frequency : 50 / 60 Hz in AC

●Power consumption : Approx. 22 VA (AC), 12 W (DC)

●Grounding : Grounding resistance ≤ 100Ω for non Ex. Type  
Grounding resistance ≤ 10Ω for Ex. Type

●Power · Signal cable entry

- : 2 × G1/2 female with adapter
- : 2 × 1/2NPT female with adapter
- : 2 × M20 female with waterproof ground
- : G1/2 with pressure resistance packing (option for TIIS explosionproof type)

●Sensor cable entry (Separate type)

- : 1 × G1/2 female with adapter
- : 1 × 1/2NPT female with adapter
- : 1 × M20 female with waterproof ground

Display and output

- Display : Blue dot matrix LCD with back light  
128 × 64 pixels (59 × 31 mm)  
Switchable 4 screens, each has 1 to 3 lines for presentation of followings:  
Flow rate in bar graph, total flow, flow rate in trend graph in % and others including setting parameters and diagnosis data
- Current output : 4 to 20 mA DC (Max. 22 mA)  
Load resistance Max. 1 kΩ
- Pulse output : Open collector output  
Rating : 32 V DC, 100 mA or less  
20 mA or less (100 Hz < f ≤ 10 kHz)  
Residual voltage at close  
< 1.5 V when load current is ≤ 1 mA  
< 2.5 V when load current is ≤ 10 mA  
< 5 V when load current is ≤ 20 mA  
100 mA or less (f ≤ 100 Hz)  
Residual voltage at close  
< 0.2 V when load current is ≤ 10 mA  
< 2 V when load current is ≤ 100 mA  
Output frequency : Max. 10 kHz  
Pulse rate : 36 to 36,000,000 pulse/h (0.01 Hz to 10 kHz)  
Pulse width: One of the following selectable

- 1. Automatic : Pulse width by which duty factor becomes 50% at full scale
- 2. Duty factor : Always 1 : 1
- 3. Free setting : 0.05 to 2000 ms

- Status output : Open collector output
  - Rating : 32 V DC, 100 mA or less
  - Residual voltage at close
    - < 0.2 V when load current is  $\leq$  10 mA
    - < 2 V when load current is  $\leq$  100 mA
  - Contents of output : One of the following selectable:
    1. No status output (Standard setting)
    2. Identification of flow direction
    3. Over range
    4. Flow alarm
    5. Presetting total flow
    6. Selecting a range when double range is used
    7. Error

- Control input
  - Voltage input : 8 to 32 V DC at "ON", 2.5 V DC at "OFF"
    - Max. current 6.5 mA when  $\leq$  24 V DC
    - Max. current 8.2 mA when  $\leq$  32 V DC
    - 8 V DC or more at "ON": 2.8 mA (normal)
    - 2.5 V DC or more at "OFF": 0.4 mA (normal)
  - Contents of control input : One of the following selectable:
    1. No control input (Standard setting)
    2. Hold output
    3. Lock output at 0%
    4. Reset total flow
    5. Reset error
    6. Identify a range when double range is used
    7. Others

●Assignment of input and output terminals

Terminal	Standard setup	Switchover by reprogramming
A (A, A+ / A-)	Current output	—
B (B, B-)	Status output	Control input
C (C, C-)	Status output	—
D (D, D-)	Pulse output	Status output

- Low cutoff
  - Current output, Pulse output, Indication (Separate setting is possible)
  - Setting value : 0 to 20% F.S. at 0.1% step
  - Hysteresis : 0 to 5% F.S. at 0.1% step
- Damping time constant
  - Current output, Pulse output, Indication (Separate setting is possible)
  - Setting value : 0.0 to 100.0 s at 0.1 s step

Standard functions

- Free measuring unit setting function
  - : Volume and time unit can be created in Max. 7 characters and displayed as flow rate unit.
- Bi-directional flow measurement function
  - Flow measurement is possible in both directions.
  - : A flow-direction distinction signal is output in state output.
- Self-diagnosis function
  - The following conditions are indicated by error message;
  - Functional diagnosis : CPU, Memory, Software, Hardware, and Output connection
  - Status diagnosis : Sensor signal lost, Over range, Counter over flow, and Power fail detection.

- Memory save function for power fail
  - Operation parameters and totalized data can be stored in EEPROM (non-volatile memory) for more than 10 years. (With up to 100,000 times of rewriting, data can be stored for about ten years.)
- Testing function
  - Simulating output function for current and pulse output, loop check without calibrator
- Setting by touch sensor (Optical key)
  - Four touch sensors allow you to alter the settings without removing the cover of conversion section. These sensors work as push buttons when the cover is opened.

Accuracy \*1

- Indication and pulse output
  - ±0.3% of reading + velocity error
  - ±0.002 m/s

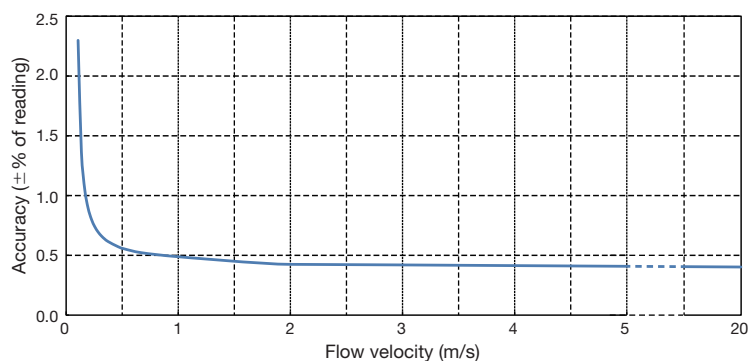

\*1 Conditions

- Fluid : Water
- Fluid temperature : 20°C
- Ambient temperature: 20°C
- Supply voltage : Rated voltage ± 2%
- Upstream / Downstream straight pipe length : 10D / 5D (D: Diameter)
- Measuring time : 100 s

- Current output accuracy
  - ±0.01 mA is added to the accuracy of indication or pulse output.

FLOW RANGE

Nominal size mm	Allowable setting range m³/h		Nominal size mm	Allowable setting range m³/h	
	Min.	Max.		Min.	Max.
25	0 to 0.531	0 to 35.3	400	0 to 136	0 to 9047
32	0 to 0.87	0 to 57.9	500	0 to 213	0 to 14137
40	0 to 1.36	0 to 90.4	600	0 to 306	0 to 20357
50	0 to 2.13	0 to 141	700	0 to 416	0 to 27708
65	0 to 3.59	0 to 238	800	0 to 543	0 to 36191
80	0 to 5.43	0 to 361	900	0 to 688	0 to 45804
100	0 to 8.49	0 to 565	1000	0 to 849	0 to 56548
125	0 to 13.3	0 to 883	1200	0 to 1222	0 to 81430
150	0 to 19.1	0 to 1272	1400	0 to 1663	0 to 110835
200	0 to 34.0	0 to 2261	1600	0 to 2172	0 to 144764
250	0 to 53.1	0 to 3534	1800	0 to 2749	0 to 183217
300	0 to 76.4	0 to 5089	2000	0 to 3393	0 to 226194
350	0 to 104	0 to 6927			

Allowable flow velocity : 0.3 to 20 m/s

## EXPLOSIONPROOF SPECIFICATIONS

## ●TIIS Technology Institute of Industrial Safty in Japan

Compact type (Converter housing: Aluminium alloy)

Model, Nominal size	UL3400C-JEx (DN25-65)	UL3400C-JEx (DN80-150)	UL3400C-JEx (DN200-3000)
Ex class	Sensor Converter Terminal box	Ex ia IIC T4 Gb Ex d [ia] IIC T4 Gb Ex d IIC T4 Gb	
Fluid temp.		-45°C to +130°C	
Ambient temp.		-20°C to +50°C	
Certificate No.	TC22293X	TC22294X	TC22295X

## ●ATEX

Certificate Number : KIWA 18ATEX0016X  
 Product : Ultrasonic Flow Meter, Type UL3400C/...-Ex,  
 : Ultrasonic Flow Converter, Type ULC400F/...-Ex,  
 : Ultrasonic Flow Sensor, Type ULS3000...-EX  
 Marking : Ultrasonic flow meter UL3400C:  
 II 2G Ex d [ia] II C T6...T3 Gb or Ex d e [ia] II C T6...T3 Gb  
 : Ultrasonic flow converter ULC400F:  
 II 2G Ex d [ia] II C T6 Gb or Ex d e [ia] II C T6 Gb  
 : Ultrasonic flow sensor ULS3000:  
 II 2G Ex ia II CT6...T2 Gb

Ambient temperature range:

-UL3400C/...-Ex : -40°C to +65°C (see following tables);  
 -ULC400F/...-Ex : -40°C to +65°C (aluminium enclosure) or  
 -40°C to +60°C (stainless steel enclosure);  
 -ULS3000...-Ex : -40°C to +70°C.

The relation between temperature class, maximum process temperature and ambient temperature is shown in the following tables:

UL3400C with aluminium enclosure

Temperature class	Max. process temperature at					
	Ta ≤ 40°C	Ta ≤ 45°C	Ta ≤ 50°C	Ta ≤ 55°C	Ta ≤ 60°C	Ta ≤ 65°C
T6	80°C	80°C	80°C	80°C	80°C	65°C
T5	95°C	95°C	95°C	95°C	95°C	65°C
T4	130°C	130°C	130°C	130°C	115°C	65°C
T3	180°C	180°C	180°C	165°C	115°C	65°C

UL3400C with stainless steel enclosure

Temperature class	Max. process temperature at				
	Ta ≤ 40°C	Ta ≤ 45°C	Ta ≤ 50°C	Ta ≤ 55°C	Ta ≤ 60°C
T6	80°C	80°C	80°C	80°C	60°C
T5	95°C	95°C	95°C	95°C	60°C
T4	130°C	130°C	130°C	100°C	60°C
T3	180°C	180°C	140°C	100°C	60°C

ULS3000

Temperature class	Max. process temperature at Ta ≤ 70°C	
	ULS3000-Ex and ULS3000 LT-Ex	ULS3000 XXT-Ex
T6	80°C	80°C
T5	95°C	95°C
T4	130°C	130°C
T3	180°C	180°C
T2	-	250°C

## Electrical Data

Power supply : 100-230Vac -15%/+10%, 22VA  
 (L, N, PE) : 12-24Vdc -10% (short-time -25%)/+30%, 12W  
 24Vac -15%/+10%, 22VA  
 24Vdc -25%/+30%, 12W  
 Um=253V

Sesnsor input circuit : In type of protection intrinsic safety Ex ia II C, with the following maximum values:  
 U<sub>0</sub> = 8, 2V, I<sub>0</sub> = 190mA, P<sub>0</sub> = 390 mW,  
 C<sub>0</sub> = 1400 nF and L<sub>0</sub> = 0, 5mH or  
 C<sub>0</sub> = 760 nF and L<sub>0</sub> = 1, 4mH or

Sensor : In type of protection intrinsic safety Ex ia II C, for connection to Flow Converter type ULC400F, or to a certified intrinsically safe circuit, with the following maximum values:  
 U<sub>i</sub> = 13, 1V, I<sub>i</sub> = 600 mA, C<sub>i</sub> = 11,6 nF, L<sub>i</sub> = 134 μH.

## I/O signal circuits

Current output, active/passive, HART  
 U<sub>n</sub> ≤ 32Vdc, I<sub>n</sub> ≤ 22mA  
 Pulse, frequency and status outputs and control input  
 U<sub>n</sub> ≤ 32Vdc, I<sub>n</sub> ≤ 100mA  
 All I/O circuits  
 U<sub>m</sub> = 250V

**ELECTRICAL CONNECTION**

[Input and output terminals of converter] ULC400F

- One current output, one pulse output, one status output, one control input (as standard)

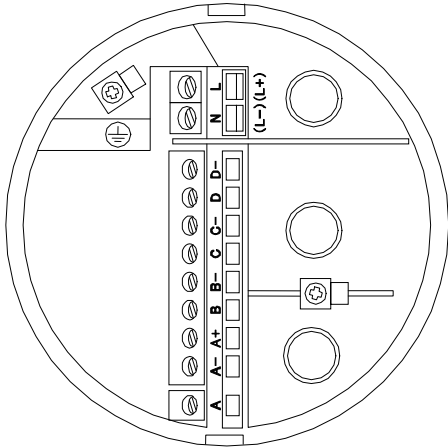

Terminal	Description
L / L+	AC power, DC power is connected to "L+" and "L-" for "+" and "-" respectively
N / L-	
⊕	Grounding terminal

Terminal	Polarity	Description (As standard)
D-	-	Pulse or status output
D	+	
C-	-	Status output
C	+	
B-	-	Control input or status output
B	+	
A+	+	Current output 4 to 20 mA by internal power
A-	-	
A	-	

The power supply terminals have a protection cover.

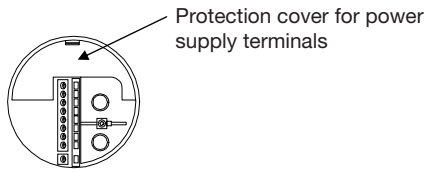

- Terminal type : Spring clamp terminal
- Applicable core size : 0.5 to 2.5 mm<sup>2</sup>
- Applicable cable diameter : 7 to 12 mm

[Separate type wiring]

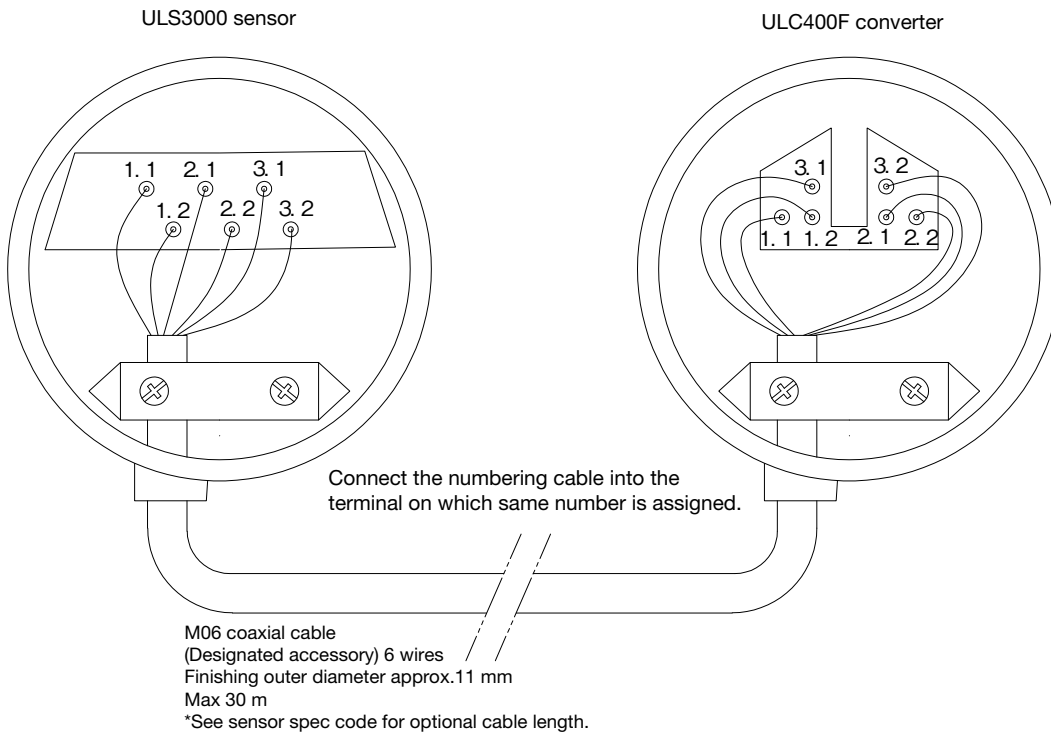

**DIMENSIONS**

● Compact type

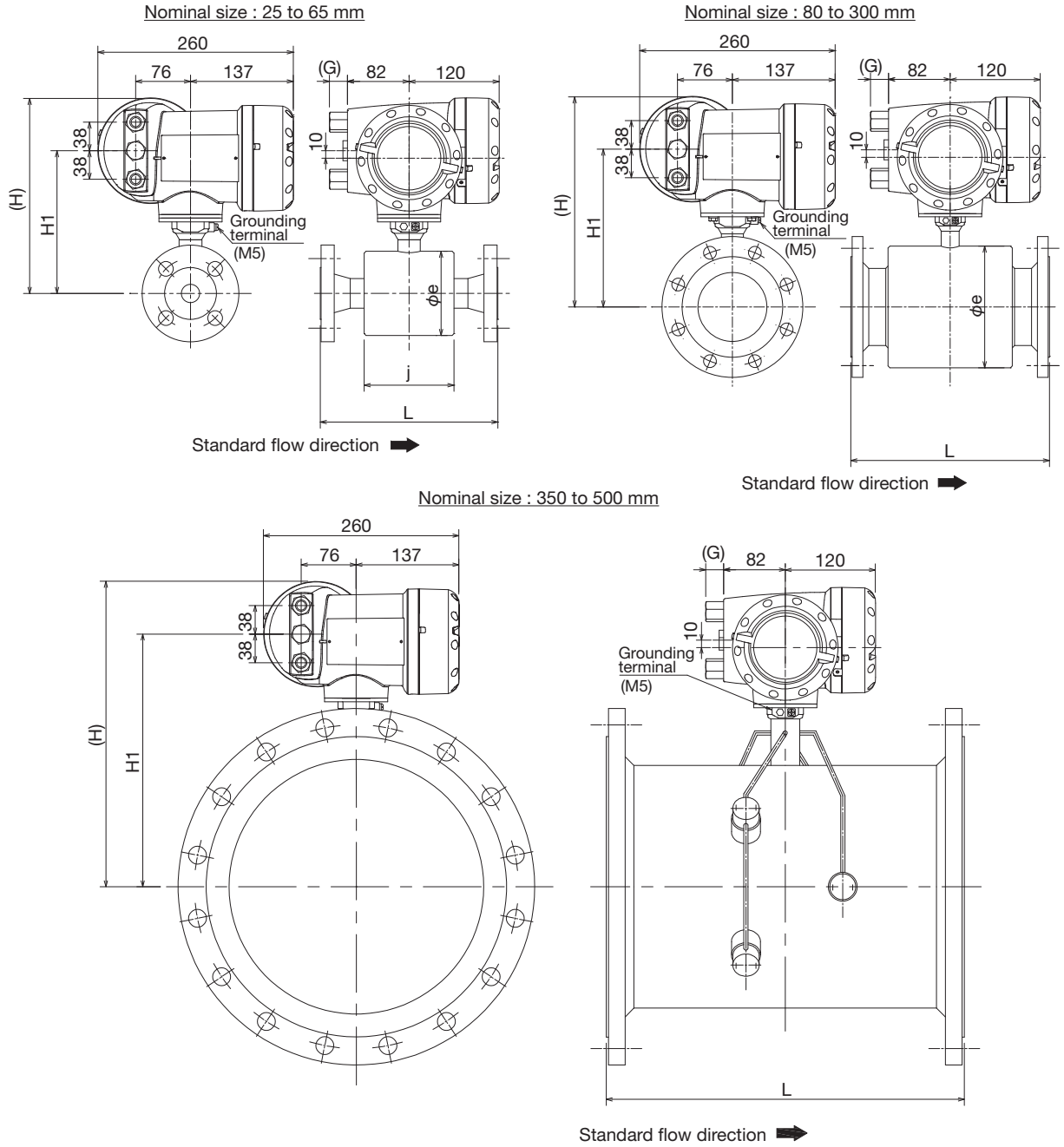

Nominal size *3 mm	Dimensions mm					Approx. Mass *2 kg
	L*1	H	H1	j	e	
25	250	253	183	120	106	13
32	260	253	183	120	106	15
40	270	253	183	120	106	19
50	300	268	198	152	133	22
65	300	268	198	152	133	24
80	300	299	229	170	190	23
100	350	312	242	190	215	24
125	350	322	252	210	237	25
150	350	338	268	236	266	34
200	400	405	335	225	359	53
250	400	432	362	260	407	60
300	500	457	387	290	457	76
350	500	419	349	-	-	76
400	600	445	375	-	-	97
450	600	470	400	-	-	111
500	600	494	424	-	-	125

\*1 Face to face dimensions L of flowmeters is that of JIS10K.

\*2 Mass of flowmeters is that of JIS10K.

\*3 JIS20K flanges of 25 to 40 mm in size are used in common to JIS10K as standard. All the dimensions of JIS10K and JIS20K are identical except for the thickness of flanges.

\*4 Length "G" : 26 mm for G1/2 female adapter, 1/2NPT female adapter.  
85 mm for G1/2 with pressure resistance packing.

Consult us for the dimensions of the flowmeters larger than 500 mm. \*4

**DIMENSIONS**

●Separate type

Sensor

Nominal size: 25 to 65 mm

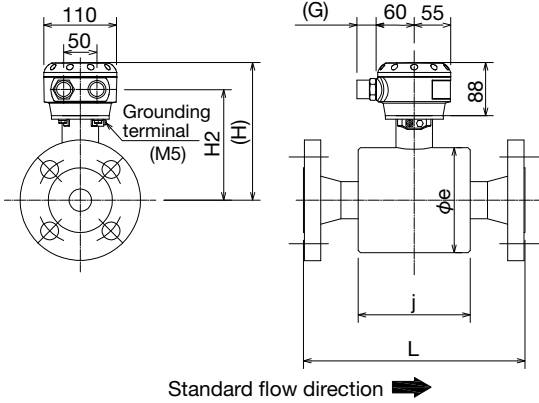

Nominal size: 80 to 300 mm

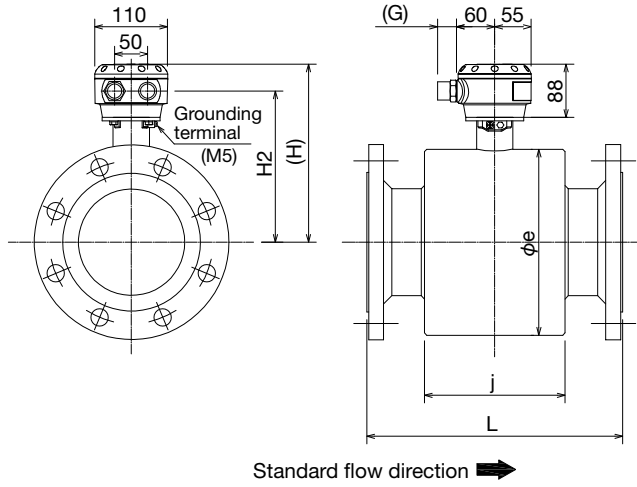

Nominal size: 350 to 500 mm

Standard version

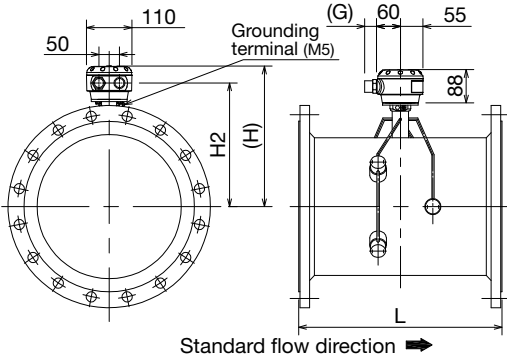

Extended temperature version / Cryogenic version

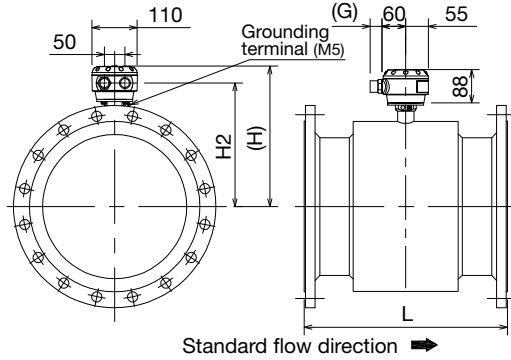

Nominal size*3 mm	Dimensions mm					Approx. Mass*2 kg
	L*1	H	H2	j	e	
25	250	186	134	120	106	7
32	260	186	134	120	106	9
40	270	186	134	120	106	13
50	300	201	149	152	133	16
65	300	201	149	152	133	18
80	300	232	180	170	190	17
100	350	245	193	190	215	18
125	350	255	203	210	237	19
150	350	271	219	236	266	28
200	400	338	286	225	359	47
250	400	365	313	260	407	54
300	500	390	338	290	457	70
350	500	352	300	-	-	70
400	600	378	326	-	-	91
450	600	403	351	-	-	105
500	600	427	375	-	-	119

\*1 Face to Face dimensions "L" is compliant with JIS10K.  
 \*2 The mass which compliant with JIS10K is described.  
 \*3 Flowmeter of DN25 to 40 mm is shipped with JIS20K flanges. (Except for the thickness, the size of JIS20K is equal to JIS10K.)

\*4 Length of Cable entry "G";  
 G1/2 female : 26 mm  
 1/2 female : 26 mm  
 G1/2 with pressure resistance packing : 85 mm

\*4 Consult us for the dimensions of the Extended temperature version and Cryogenic version larger than 350 mm.  
 Consult us for the dimensions of the flowmeters larger than 500 mm.

Converter

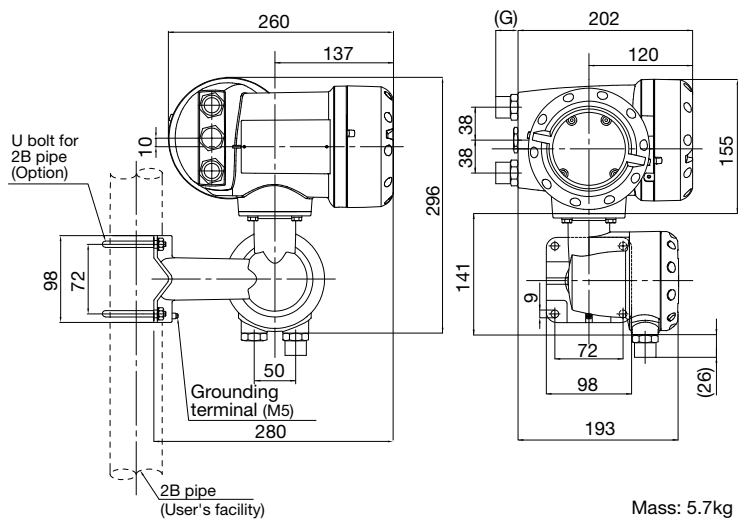

Mass: 5.7kg



## MODEL CODE

●Nominal size : 25 to 65 mm

[Model]

Explosion proof	Compact type (Sensor + Converter)	Separate type	
		Sensor	Converter
Non Ex type	UL3400C	ULS3000	ULC400F
TIIS Ex	UL3400C-JEx	—	—
ATEX Ex	UL3400C-Ex	ULS3000-Ex	ULC400F-Ex

[Sensor spec code]

Sensor spec code	VN61	4					B	0	2	2	1	0	0	0	0	3	0	0		Description	Std.
Sensor code	VN61																			ULS3000 sensor (Nominal size: 25 – 65 mm)	○
(Fixed code)		4																		Fixed code: 4	○
Nominal size		4																		25 mm / 1"	○
		5																		32 mm / 1 1/4"	
		6																		40 mm / 1 1/2"	○
		7																		50 mm / 2"	○
		8																		65 mm / 2 1/2"	
Flange standard (Nominal pressure)		5																		EN1092-1 PN40	
		6																		EN1092-1 PN63	
		7																		EN1092-1 PN100	
		A																		ASME Class 150	
		B																		ASME Class 300	
		D																		ASME Class 600	
		M																		Equivalent to JIS 20K *1	
Explosionproof		0																		Without (Non Ex type)	○
		1																		ATEX Ex	
		9																		TIIS Ex	
Cable entry For sensor cable *2		1																		Compact type	○
		4																		Separate type: 1/2 NPT with adapter	
		5																		Separate type: G1/2 female with adapter	
		6																		Separate type: M20 × 1.5 with water proof ground	
Model		1																		Compact type	○
		2																		Separate type	
Materials of sensor tube / Flange		B																		SS316 / SS316L	○
Sensor cable		0																		Compact type: N/A Separate type: 5 m	○
		1																		Separate type: 10 m	
		2																		Separate type: 15 m	
		3																		Separate type: 20 m	
		4																		Separate type: 25 m	
		5																		Separate type: 30 m	
Calibration		0																		Standard calibration	○
(Fixed code)								2	2	1										Fixed code: 221	○
Protection level		0																		IP66 / 67	○
		2																		IP68 *3	
(Fixed code)											0	0	0	0	3					Fixed code: 00003	
Process temperature		0																		Compact type: ≤145°C / Separate type / Standard version: ≤180°C	
		1																		Separate type / Extended temperature version : -45 to 250°C	
		2																		Separate type / Cryogenic version : -200 to 180°C	
(Fixed code)											0	0							Fixed code: 00		
Customized option		Blank																		Without customizing	○
		/Z																		With customized option	

\*1 Flow meter of Nominal size 25 to 40 mm is combined with JIS20K flange.

For Nominal size 25 to 40 mm, JIS20K flange with Sensor spec code "M" must be selected.

(Except for thickness, the size of JIS20K is equivalent to JIS10K.)

\*2 Sensor cable entry at converter side is also same type.

\*3 IP68 is available for separate type only. When order "Cryogenic version", IP68 must be selected.

●Nominal size : 80 to 300 mm

[Sensor spec code]

Sensor spec code	VN62	4								0 ● 2 1 ● 0 0 0 0 3 ● 0 0	Description	Std.
Sensor code	VN62										ULS3000 sensor (Nominal size: 80 – 300 mm)	○
(Fixed code)		4									Fixed code: 4	○
Nominal size	A										80 mm / 3"	○
	B										100 mm / 4"	○
	C										125 mm / 5"	○
	D										150 mm / 6"	○
	E										200 mm / 8"	○
	F										250 mm / 10"	○
	G										300 mm / 12"	○
Flange standard (Nominal pressure)	2										EN1092-1 PN10 (DN200 – 300 mm)	
	3										EN1092-1 PN16 (DN100 – 300 mm)	
	4										EN1092-1 PN25 (DN100 – 300 mm)	
	5										EN1092-1 PN40 (DN80 – 300 mm)	
	A										ASME Class 150	
	B										ASME Class 300	
	D										ASME Class 600	
	M										Equivalent to JIS 20K	
N										Equivalent to JIS 10K	○	
Explosionproof	0										Without (Non Ex type)	○
	1										ATEX Ex	
	9										TIIS Ex	
Cable entry For sensor cable *1	1										Compact type	○
	4										Separate type: 1/2 NPT with adapter	
	5										Separate type: G1/2 female with adapter	
	6										Separate type: M20 × 1.5 with water proof ground	
Model	1										Compact type	○
	2										Separate type	
Materials of sensor tube / Flange	2										SS316 / SS316L / slip on welding	
	3										Carbon steel / Carbon steel / slip on welding	○
	B										SS316 / SS316L / butt welding	
	C										Carbon steel / Carbon steel / butt welding	
Sensor cable	0										Compact type: N/A Separate type: 5 m	○
	1										Separate type: 10 m	
	2										Separate type: 15 m	
	3										Separate type: 20 m	
	4										Separate type: 25 m	
	5										Separate type: 30 m	
Calibration	0										Standard calibration	○
Measuring sensor housing material *2, *3	0										Carbon steel	○
	2										SS316L	
(Fixed code)									2 1		Fixed code: 21	○
Protection level	0										IP66 / 67	○
	2										IP68 *4	
(Fixed code)									0 0 0 0 3		Fixed code: 00003	
Process temperature	0										Compact type: ≤145°C / Separate type / standard version: ≤180°C	
	1										Separate type / Extended temperature version : -45 to 250°C	
	2										Separate type / Cryogenic version : -200 to 180°C	
(Fixed code)									0 0		Fixed code: 00	
Customized option	Blank										Without customizing	○
	/Z										With customized option	

\*1 Sensor cable entry at converter side is also same type.

\*2 When order "Cryogenic version", [2: SS316L] must be selected.

\*3 [0: Carbon steel] is available for "Standard version" or "Extended temperature version".

\*4 IP68 is available for separate type only. When order "Cryogenic version", IP68 must be selected.

●Nominal size : 350 to 2000 mm

[Sensor spec code]

Sensor spec code	VN63	4								0	●	2	1	●	0	0	0	0	3	●	0	0		Description	Std.
Sensor code	VN63																							ULS3000 sensor (Nominal size: 350 – 2000 mm)	○
(Fixed code)		4																						Fixed code: 4	○
Nominal size		H																						350 mm / 14"	○
		K																						400 mm / 16"	○
		L																						450 mm / 18"	○
		M																						500 mm / 20"	○
		N																						600 mm / 24"	○
		P																						700 mm / 28"	○
		R																						800 mm / 32"	○
		S																						900 mm / 36"	○
		T																						1000 mm / 40"	○
		U																						1200 mm / 48"	
		V																						1400 mm / 56"	
	W																						1600 mm / 64"		
	X																						1800 mm / 72"		
	Y																						2000 mm / 80"		
Flange standard (Nominal pressure)			1																					EN1092-1 PN6 (DN1200 – 2000 mm)	
			2																					EN1092-1 PN10 (DN350-1000mm)	
			3																					EN1092-1 PN16	
			4																					EN1092-1 PN25	
			5																					EN1092-1 PN40	
			A																					ASME Class 150 (DN350-600mm)	
			B																					ASME Class 300 (DN350-600mm)	
			D																					ASME Class 600 (DN350-600mm)	
			M																					Equivalent to JIS 20K	
		N																					Equivalent to JIS 10K	○	
Explosionproof			0																					Without (Non Ex type)	○
			1																					ATEX Ex	
			9																					TIIS Ex	
Cable entry For sensor cable *1			1																					Compact type	○
			4																					Separate type: 1/2 NPT with adapter	
			5																					Separate type: G1/2 female with adapter	
			6																					Separate type: M20 × 1.5 with water proof ground	
Model			1																					Compact type	○
			2																					Separate type	
Materials of sensor tube / Flange			2																					SS316 / SS316L / slip on welding	
			3																					Carbon steel / Carbon steel / slip on welding	○
			B																					SS316/SS316L / butt welding	
			C																					Carbon steel / Carbon steel / butt welding	
Sensor cable			0																					Compact type: N/A Separate type: 5 m	○
			1																					Separate type: 10 m	
			2																					Separate type: 15 m	
			3																					Separate type: 20 m	
			4																					Separate type: 25 m	
			5																					Separate type: 30 m	
Calibration			0																					Standard calibration	○
Measuring sensor housing material *2, *3			0																					Carbon steel	○
			2																					SS316L	
(Fixed code)			2	1																				Fixed code: 21	○
Protection level			0																					IP66 / 67	○
			2																					IP68 *4	
(Fixed code)			0	0	0	0	3																	Fixed code: 00003	
Process temperature			0																					Compact type: ≤145°C / Separate type/standard version: ≤180°C	
			1																					Separate type / Extended temperature version: -45 to 250°C	
			2																					Separate type / Cryogenic version: -200 to 180°C	
(Fixed code)			0	0																			Fixed code: 00		
Customized option																								Blank Without customizing	○
																								/Z With customized option	

\*1 Sensor cable entry at converter side is also same type.  
 \*2 When order "Cryogenic version", [2: SS316L] must be selected.  
 \*3 [0: Carbon steel] is only available for "Extended temperature version".  
 \*4 IP68 is available for separate type only. When order "Cryogenic version", IP68 must be selected.

[Converter Spec. code]

Converter Spec. code	VN35	4				6 0 0 ● 2 1 0 0 0 3 ●	Description	Std.
Converter Code	VN35						ULC400 Converter	○
(Fixed code)		4					Fixed code: 4	○
Type		5					Compact type	○
		K					Separate type	
Power supply		A					100 – 230 V AC	○
		1					24 V DC	
Explosionproof		0					N/A (No Ex)	○
		1					ATEX Ex	
		9					TIIS Ex	
Cable entry		4					1/2 NPT with adapter	
		5					G1/2 female with adapter	○
		6					M20 × 1.5 with water proof ground (ATEX Ex proof: M20 × 1.5 female)	
		9					G1/2 with pressure proof adapter (only available for TIIS Ex proof type)	
(Fixed code)					6 0 0	Fixed code: 600		
Converter housing						1	Aluminium alloy	○
						2	SS316	
(Fixed code)						2 1 0 0 0 3	Fixed code: 2100003	
Orientation of display						A	Version A	○
						B	Version B	
						C	Version C	
Customized option						Blank	Without customizing	○
						/Z	With customized option	

Orientation of display

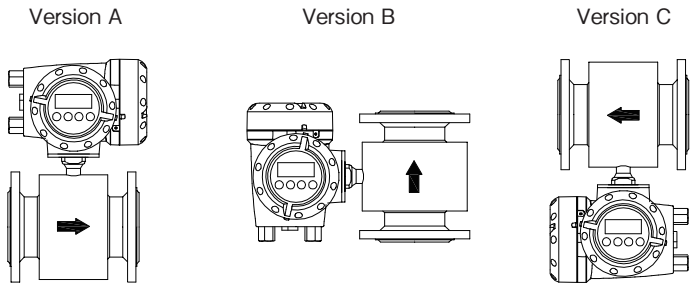

The arrow indicates flow direction as standard. The opposite direction can be set by changing the setting.

POINTS TO BE CHECKED BEFORE MODEL SELECTION

It may be unable to make measurement when falling into the following conditions.

When it's difficult to judge whether it can be used or not, we can arrange preliminary test by Clamp-on type flowmeter.

- Liquid
  - The liquid containing a lot of bubbles (over 2% only as a guide).
  - The liquid containing slurry and solid material (over 5Vol.% only as a guide).
  - Liquids which attenuate Ultrasonic waves (Typical example:acetic acid)

\*This flowmeter cannot be used for High concentration acetic acid aqueous solution (above 50%) .

STANDARD ACCESSORIES

- Parameter sheet : 1
- Instruction manual : 1

OPTION

- G1/2 watertight cable glands for cable entry [Code : WG]
- Number of cable entries: 3 [Code : 3G]

ORDERING INSTRUCTIONS

Specify the following when ordering :

- Model and specification codes  
Example : model UL3400C  
Sensor spec code : VN6144M011B00221000003000  
Converter spec. code : VN3545A0560012100003A
- Full scale flow range (no need for NS option)
- Orientation of display on converter: Either A, B or C See above figures.
- Optional requirements marked with above codes, if required.
- Fluid name

\* Specification is subject to change without notice.



Head Office : Shiba Toho Building, 1-7-24 Shibakoen, Minato-ku, Tokyo 105-8558  
Tel : +81-3-3431-1625 (KEY) ; Fax : +81-3-3433-4922  
e-mail : overseas.sales@tokyokeiso.co.jp ; URL : https://www.tokyokeiso.co.jp